

64th Anniversary Production Sale

Wednesday April 8th, 2009

Selling Three Herd Sire
prospect sons of Julian B571



1 Beckton Red Angus

Foundation Herd of the Red Angus Breed

Accommodations

Holiday Inn

Sale Headquarters, Friday Evening Dinner
307.672.8931, I-90, Exit 25
Beckton Sale Rate: \$85

Best Western Sheridan Center

307.674.7421, 612 N. Main Street
Beckton Sale Rate: \$72

Days Inn

307.672.2888, 1104 Brundage Lane

Comfort Inn

307.672.5098, 1450 Brundage Lane

Super 8 Motel

307.672.9725, 2435 N. Main Street

Transportation

Great Lakes Airlines

Several daily flights to/from Denver
Contact Holiday Inn for airport transfers

Avis Car Rental

T: 307.672.2226, Sheridan Airport

Free Delivery

We pay for delivery for all bulls and registered heifers throughout the Continental U.S. If you do bring a trailer to haul your own, \$50 will be deducted from the price of each bull or registered heifer. Most of the sale cattle will be delivered from 1-3 weeks after the sale, although we will try to accommodate special needs. Although there occasionally are limitations, in most cases we can deliver the cattle directly to your ranch.

Sight-Unseen Purchase (by mail or phone)

If you are unable to attend the sale, we can help you select the bulls or females to fit your needs. Give us a phone call, letter, fax or e-mail (please refer to the the back cover), and we can make arrangements to handle bidding according to your directions. Bulls are bought at the lowest price, and satisfaction is guaranteed on bulls purchased sight unseen. Many of our repeat customers buy their bulls this way.

To provide us adequate time to assist you, please contact us before noon of the day prior to the sale.

Payment

Payments can be made with cash, check payable to Beckton Stock Farm, or Visa/Mastercard on sale day.

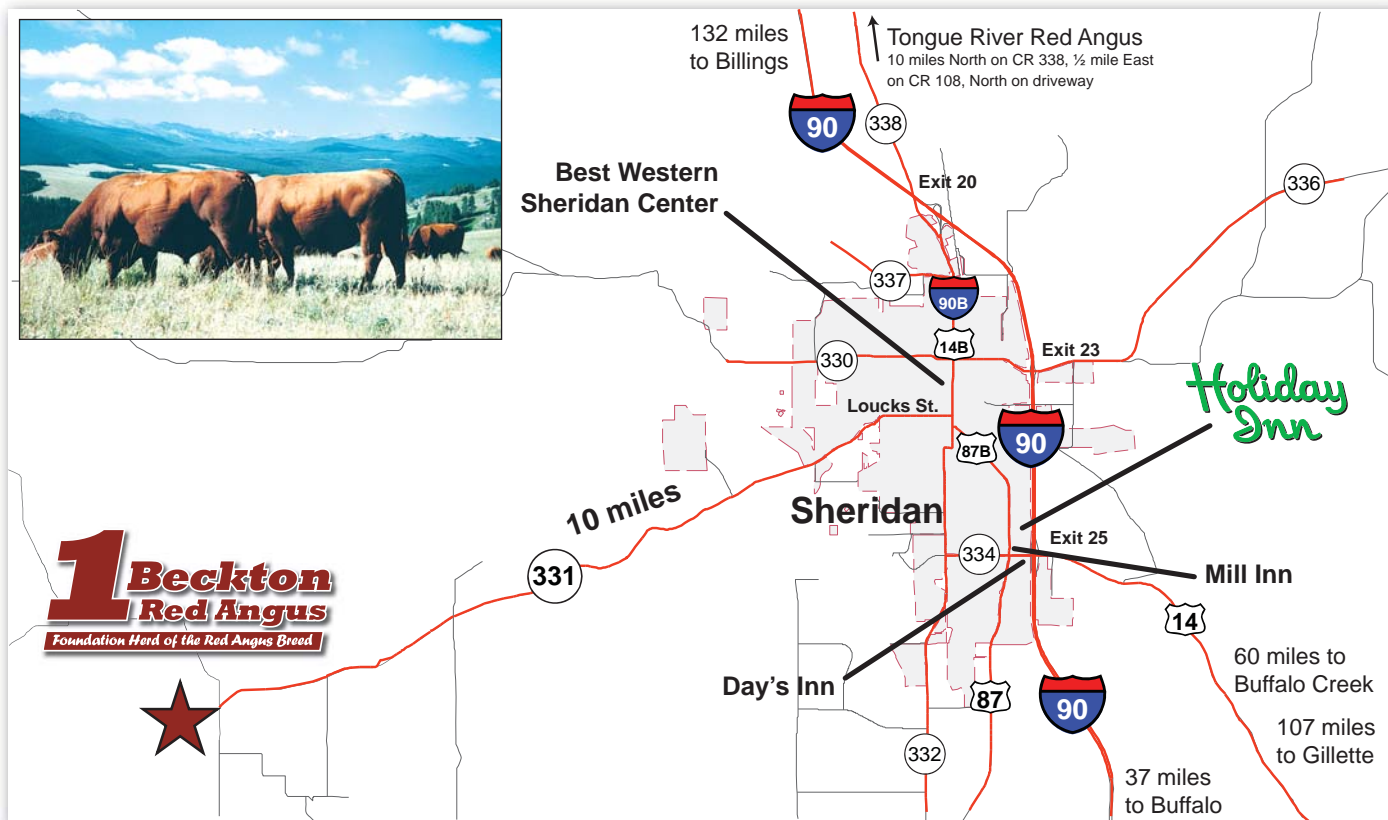

Credit for many of the photographs in the catalog should go to Kim Wolfe (*Record Stockman*), Doug Hogan (*Tri-State*), Brenda Stewart, and Diane Vaneck.

64th Anniversary Production Sale

Beckton Ranch

9½ miles West of Sheridan

Wednesday, April 8, 2009

12 o'clock noon

Lunch at 11 am

236 Bulls • 44 Heifers

Selling in catalog order, heifers sell following the bulls

Please join us for a complimentary
Customer Appreciation dinner
Wednesday evening at the Holiday Inn.

Phone: 307.674.6095



Beckton Red Angus is the Red Angus breed's founding herd. Started in 1945, it has since maintained the longest continuous performance testing and improvement program in the industry. When the Red Angus Association of America was formed nine years later, Red Angus adopted performance testing into its By-laws, the first breed to do so. There are no other cattle with this long history of performance-based genetic selection, so that today we believe our cattle do more things better.

Some Facts:

- ▶ **Beckton is the #1 herd for Low Maintenance Energy requirements, with the lowest average Maintenance EPD of any major herd.** Five of the top ten sires in the breed for lowest Maintenance Energy are Beckton sires. The average Beckton bull in this sale is in the top 5% of the entire breed for low Maintenance Energy EPD. **No other set of sale bulls will do a better job cutting your cowherd maintenance requirements.**
- ▶ **Beckton is also the #1 herd for easy calving, with the highest average Calving Ease EPD of any major herd.** Seven of the top ten sires in the breed for low Birth Weight EPD are Beckton sires. The average Beckton bull in this sale is in the top 5% of the breed for calving ease. **No other set of sale bulls will do a better job of giving you more live calves.**
- ▶ **Best of all, our bulls also lead in total birth to market weight growth.** The average Yearling Weight EPD of the sale bulls is +55, and total birth-to-yearling growth is +58, better than the majority of other Red Angus. This is performance you don't get from other low maintenance or calving ease cattle.
- ▶ There is no other sale offering which combines such good growth traits with this low cow maintenance, and high calving ease, and in so many bulls. **This results from 64 years of performance testing and selection.**
- ▶ **Beckton has produced some of the top all-round carcass sires in the Red Angus breed for many years.** Beckton also produced the highest impact, most "in demand" sire in the Red Angus breed today – Beckton Julian B571 – another top carcass sire and the highest Stayability EPD sire in the entire breed.
- ▶ Plus 64 years of selection for the convenience traits – **cowherd fertility – good udders and milk – altitude adaptation – and good dispositions.** All of the sale bulls have been screened for disposition, and those few that were questionable were not included. Along with good dispositions, our high mountain and big range environment has given us cattle with **good feet and legs.**



Auctioneer Roger Jacobs
406.698.7686



Cam and Trish



Spike and Jo



Sal Forbes

Additional Sale Information

- ▶ The animals sell in catalog order.
- ▶ All animals are registered with the Red Angus Association of America, and registration certificates will be transferred to the new owners.
- ▶ All bulls selling have passed a rigorous fertility exam that included live semen evaluation, scrotal measurements, and reproductive tract examinations.
- ▶ Beckton has a comprehensive herd-wide health program which includes vaccinations for 7-Way, IBR, BVD, PI3, BRSV, Lepto, and ivermectin. The heifers are also vaccinated for bangs and vibrio.
- ▶ We plan to get semen collected on some of the bulls before the sale. Otherwise, we will work with the buyer to collect after the sale but before delivery.



Jerry Gliko
Western Livestock
Journal
406.656.2515



Alan Sears
Western Livestock
Reporter
970-454-3986



Doug Hogan
Tri-State
Livestock News
605.391.5346



Curt Cox
Wyoming Livestock
Roundup
307.630.4604



Del Tinsley
Wyoming Livestock
Roundup
307.234.2700



Eric Mack
Wyoming Stockman
Farmer
406-366-2111

Catalog Table of Contents

The Beckton Program 4	Sale Terms & Conditions .81
The Bulls 10	RAAA Herd EPD Tables .82
The Yearling Heifers 57	Sire Bloodline Charts . . . 84
Semen Available 69	Beckton History 87
Reference Sires 70	Lot-Tag Cross Ref 88
Terminology 80	Special Semen Sires 89



Bob Hough
817.296.0976



Tommy "T.V." Jones
Record Stockman
307.632.5118



Ron Frye
Working Ranch
406.209.1640

THE WALDO FORBES FAMILY
Sal; Spike and Jo; Cam and Trish;
Doug and Sheila; Cherry and John
Julia and Ed; Sarah and Doug;
Elfie and Ruth



REGISTERED RED ANGUS CATTLE AT
Foundation Herd of the Red Angus Breed
Serving You since 1945
BECKTON STOCK FARM
37 Beckton Drive
SHERIDAN, WYOMING 82801
Phone (307) 674-6095 day; 674-8162 evening; 672-7281 fax
beckton@wavecom.net



Dear Friends and Cattlemen,

The Forbes family welcomes you to our 64th annual sale of Red Angus bulls and heifers. Following the sale, you are all cordially invited to a complimentary roast beef dinner at the Holiday Inn.

The cattle did well over a dry summer, and continued doing well all winter at Darr. The health we see in the bulls is better than ever. Perhaps related, the fertility test results were exceptional. Another area we noted at the end of the test was that the bulls were very quiet and easy to handle. We are confident these bulls will go out and do well for their future owners.

This year's sale features three herd sire prospects by Beckton Julian B571. We have heard over and over from people how much they like their Julian daughters, and we see how many Julian herd sires are out working in other herds. His semen hasn't been on the market for several years, and the offering of three herd sire quality sons is a unique opportunity.

While the economy ahead isn't certain, the beef cattle industry has been reducing inventory for a number of years, and is well positioned when the recovery comes. If grain prices and feed costs continue high into the future, the best way to handle these feed costs is with cattle that need less.

The Beckton herd continues to have the lowest overall cow Maintenance Energy EPD's of any major cowherd. And the bulls in our sale will have the lowest overall Maintenance Energy EPD that can be found at any major sale. Almost all of the bulls in this catalog will have Maintenance EPD's under the Red Angus breed average of +4. Selecting bulls with Maintenance EPD's under that number will help you reduce overall operating costs into the future.

Because we have been selecting for moderate size combined with growth for so many years, you will find a higher proportion of bulls and heifers here that are both low in Maintenance and high in growth than you would find at other sales. The high calving ease, carcass quality, and fertility are added benefits.

We invite you to come see our bulls and heifers on the 8th of April. Sale information including free delivery and sight-unseen purchasing is on the inside front cover of the catalog. If we can help you in any other way, just let us know. We hope to see you in April.

Sincerely,



Shelley, Stephen, Trish, Tallie, and Cam

BRED-IN, NOT FED-IN, GENETIC SUPERIORITY
APRIL: SPRING BULL SALE FALL: RED ANGUS FEMALES
RED ANGUS BREEDING STOCK AVAILABLE YEAR ROUND

The Beckton Program

Cow Size

The goal for Beckton's program has always been to develop breeding seedstock which offer increased levels of performance for the commercial cattleman. Increased performance does not mean maximizing weight and size, which have already reached the upper limit of economic value for the packer and consumer. It does, however, mean increasing performance related to calving percentage and weaning percentage; and increasing performance related to cow maintenance requirements and "pounds of calf per acre" efficiency.

Size Matters

Beckton cattle are already big enough for the consumer and the packer. Using yearling weight EPD as the best available indicator of market size, the average for our sale bulls is +58. The Red Angus breed average for 2008-born animals is +56, so on market size our cattle are directly comparable to industry standard. They are comparable for weaning weight EPD also, so Beckton cattle offer weaning and yearling performance very similar to today's mainstream Red Angus.

The big difference between Beckton's program and others is that we select for additional weaning and yearling weight, but with the restriction that we have maintained about the same cow size as 30 years ago. In contrast, the industry has allowed cow size to increase at the same rate as calf size. Cow size is the largest factor determining maintenance requirements. Our goal over the past 30 years has been to increase efficiency, not size. No other seedstock breeding program has had such a goal, or maintained it for so long.

Beckton Cow Weight Average (lb.)

Year	1978	1982	1986	1990	1994	1998	2002	2006	2008
Wt.	1,126	1,126	1,064	1,115	1,067	1,125	1,104	1,093	1,107

(mature lactating cows taken at weaning)

Cow weights vary from year to year depending on body condition or other short term factors. But overall our cow size has stayed fairly constant over time.

The Industry Problem

As shown on the graph on the next page, industry-wide cow size has increased by more than 27% over this same period. But look at the industry-wide trend in feed use per cow over the same period, shown by the use of hay:

Industry Hay Use (tons/animal unit)

Year	1978	1982	1986	1990	1994	1998	2002	2006
Hay Usg.	1.43	1.62	1.91	2.00	1.94	1.99	2.08	2.05
Pct.	100%	113	134	140	136	140	146	143

(Src.: USDA Econ. Research Service, 2006 is newest available data)

Industry-wide, production per cow is up about 22%, but hay consumption per cow has risen over 50%.

Why does hay use increase at a faster rate than cow size or production per cow? Hay and grain are supplements to the cow's main diet, which is grass, and grass supply is relatively fixed by environment. Each increase in cow feed requirement must be met entirely by supplements, or by a combination of supplement and reduced stocking rate. A small increase in cow feed requirement leads to a reduction in stocking rate or a large increase in higher-cost, supplemental feed needs.

If any gains have been achieved in the feedlot sector due to increased animal growth, they have been overwhelmed by increased cost of production in the cow-calf sector.

The Beckton Year-Round Crew:



Tom Peek



Randy Zier



Mick McClure



Alan Sanders

Efficiency

30 Years of Change: Industry-Wide

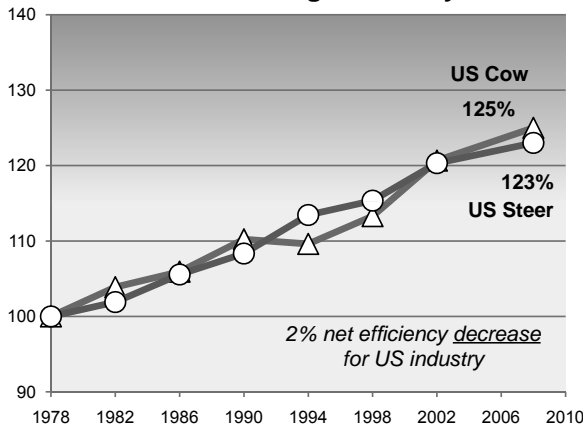

The graph at left shows how, for the U.S. cattle industry overall, the increase in average calf weights, as measured by steer slaughter weights, has been directly matched by an increase in average cow weights. (Percentages are based on USDA slaughter weight data for steers and cows respectively, using 1978 as a base year. Data for heifers slaughtered shows an identical trend.) Over 25 years, there has been minimal change in overall cowherd efficiency.

This graph shows the failure of cross-breeding and composite breeding to do little more than simply increase general cattle size. In the promotion of composites, the impact of retained heterosis on mature weight is too often ignored. Crossbreeding and composites are sold as a free lunch, but they aren't necessarily free after all.

We have accomplished this by selecting for growth, restricting birth weight and cow size creep, and multiplying each incremental change rapidly throughout our entire cowherd and all of our bloodlines. Usually this has meant working within our own bloodlines rather than introducing out-crosses, because the outside genetics for the direction we wanted to go haven't been available. The overall key to success is simply that we have been making small progress in multiple traits, but doing it consistently over a very long period of time.

30 Years of Change: Beckton

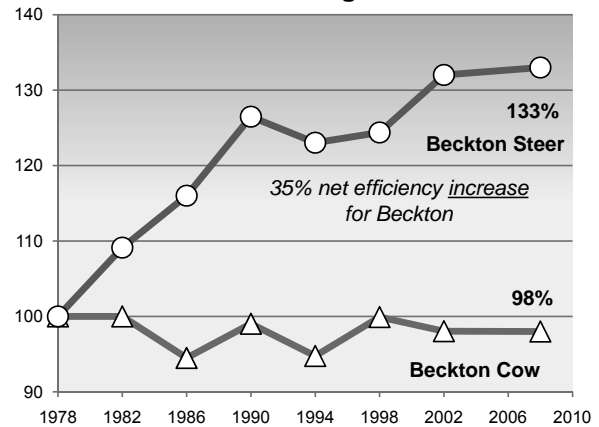

The graph at right shows Beckton cowherd data over the same time period.

1. Beckton cow size has shown negligible change over the past 25 years, while the industry has experienced a substantial increase in cow size.
2. Even without increasing cow size, we have raised the rate of early growth in Beckton cattle, using intense genetic selection and generation turnover, and by more than the rest of the industry.
3. The net change in efficiency as measured simply by "calf weight divided by cow weight", is significantly higher with Beckton's genetic program, compared to mainstream cross-breeding based on retained heterosis.

These eight combine for 128 years at Beckton



Sherry Kobielus



Polly Burfiend



Travus Adsit



Jane Redding

Additional Facts about the Beckton Program

- Birth weight**
- ▶ Every sire entering our own program is used first on our own heifers, then on our cows.
 - ▶ We have never used high birth weight sires in any part of our program, so big birth weights are rare.
 - ▶ We get the pay weight, but with lower birth weights and greater calving ease.
 - ▶ Full production from heifers. We use the same bulls on heifers and cows.

- Growth**
- ▶ Weaning efficiency, and rate of gain to slaughter weight second to none.
 - ▶ Growth traits must be consistent with maintaining maternal qualities.
 - ▶ Beckton cattle are ideally sized for today's packer demand.

- Hardiness**
- ▶ Every cow in the herd has spent part of her life in the Big Horn Mountain summer range, at elevations from 7,000 to 10,500 feet.
 - ▶ In 2001 we PAP tested all of our herd sires. The herd average PAP score was 32.5 at 4000', equivalent to a herd average PAP of 39 at 8000' (excellent scores).
 - ▶ By the time she is 5, our average cow will have been trailed over 80 miles, above and beyond normal pasture rotation.

- Efficiency**
- ▶ The typical dam of our bulls weans over 50% of her body weight in 205 days, under range conditions, with no creep-feeding.
 - ▶ The average dam produces over 100% of her own body weight in a year.
 - ▶ The average mature cow (age 5+) weighs about 1100-1125 pounds.

- Fertility**
- ▶ Every bull in our program is used in natural service, with 30-50 heifers/cows.
 - ▶ Every cow in our program must cycle naturally and breed early under range conditions.

- Value**
- ▶ Beckton Red Angus produce more growth without high birth weights.
 - ▶ They are the one-bull solution that can be used on both heifers and cows.
 - ▶ Carcass quality is an extra benefit.

- Integrity**
- ▶ Beckton has been genetically improving Red Angus since 1945, a 20-50 year lead time over other producers.
 - ▶ It is a complete, genetically sound breeding program, which demands whole-herd performance.



*Sue and Forest Dunning
Tongue River Red Angus, 307.750.2454*



*Joe and Connie Mushrush
Mushrush Red Angus, 620.273.8581*

Management

One Bull – the Simple Solution is the Best Solution

Many cattlemen use Beckton bulls for their heifers because of their low birth weights and high calving ease. Our bulls are even better when used on cows, because replacement heifers tend to be selected from calves out of older cows. **Keeping replacement heifers sired by Beckton bulls is the quickest way to limit cow size creep and to moderate cow size for the future.** In our own program we use the same bulls on both heifers and cows. Every bull is used his first year with heifers to evaluate calving ease, and used in future years with older cows. We get calving ease, growth, and moderate-sized replacements, all with the same bull.

Quietness and Ease of Handling

The necessity of record keeping means that our cattle will be handled much more than commercial cows. **This benefits our seedstock customers because our cattle will be quieter and easier to handle.** Good disposition is one of our most valued traits.

Removing the Bull from Bull Testing

Our bulls are managed to give our customers many years of productive service. We have been testing breeding bulls for 45+ years, longer than almost anyone. Our own breeding is based on natural service, not AI, so we see how bulls work in the pasture. **We use these bulls with our own cows, on every kind of terrain and high in the Big Horn Mountains.** For the first twenty years our bulls were raised and tested at home here in Wyoming. They received some grain, but otherwise grass pasture and dry hay – a forage dominated diet. In 1979 we moved our test to the Kugler's in Nebraska, where the bulls got a ration including silage, corn and protein.

It was 29 years ago that we started bringing home from Kuglers, and used them with our own cows. **The improvement in libido and breeding performance in these bulls was dramatic.** While it is possible to feed bulls improperly under any program, we would strongly question those who promote the notion of any advantage to “forage-raised” bulls.

We have used over 400 of these bulls in our own herd, and have never had a bull fall out of our program prematurely due to his feeding or testing management. Beckton Julian B571, Lancer F442, and all of our other great sires were fed and tested at the Kugler facility. We think any notion that forage raised bulls will somehow hold up better or last longer, is a myth. **This winter we are retiring Beckton Champ H024, who has spent the**

last few years doing clean up duty on 400 cows on 10,000 acres high in the Big Horns, going on 10 years of age!!

Selection for Industry Requirements

In order to make selection decisions appropriate to the commercial beef industry, seedstock cattle need to be managed and measured under conditions which will approximate the commercial industry. **Our cows are run strictly on grass, with hay only if weather conditions require it, because that is how the commercial industry runs cows.** However, almost all commercial calves go into feedlots before slaughter, so feedlot performance and efficiency is an important trait for calves. **Simply put, a producer needs to know how his cows perform on grass, and how his calves perform with feed.**

Our bulls are run on a performance test designed to provide the fairest basis of comparison among them, and this requires a compromise. Our bulls receive a “growing” ration high in roughage and protein and not as high in energy as a steer would receive. **We want to get a good measure of gainability with which to compare bulls, but we don't want the bulls fat.**

Craig Uden, Mitch Ziebell of Darr, NE

In the fall of 2005, Lane Kugler retired and sold his bull testing facility to a neighboring operation - Craig Uden with Darr Feeders. **The name change is somewhat misleading, because the bulls are still in the same pens they have always been in.**

Unlike the Kugler's, Craig actually runs a complete operation vertically integrated from commercial cow-calf production all the way to the packer door. Bull testing is a natural fit. Craig Uden started at Darr in 1984, and has served on numerous committees and organizations in Nebraska. Mitch Ziebell has joined him and has taken over responsibility for the daily management of our bulls at Darr. **We have been very impressed with what conscientious care Mitch oversees all aspects of the bull management.**



Craig Uden, Darr Feedlot Manager
Photo courtesy of the Lexington Clipper-Herald



Contributing to the success of the Beckton Program...



*Matt Goold
Clips and washes
the bulls*



*Cody Cunningham
Brand Inspector*



*Charles Larsen
Brand Inspector*



*Dr. Robert Bohlender
Fertility tests
the bulls*



*Sarah and Mark
Schreiber
Our vets*



*Bob Milner
Our AI tech*

Using New Selection Tools

Maintenance EPD

This EPD predicts the relative feed energy requirement for maintenance, for cows produced by a sire or female. A bull with an ME of -3 (minus 3) is expected to sire replacement daughters which will need 10 fewer mcals of energy per month than a bull with an ME of +7.

We believe this is an important EPD because feed costs, both direct and indirect through ranch overhead, make up by far the largest proportion of operating costs. It can have much more direct impact on ranch profitability than Marbling or Ribeye EPD for example.

The Beckton herd is the breed's top herd for low maintenance energy requirements, with the lowest average herd ME of any major herd, based on all sires listed on National Sire Evaluation. **The average Beckton cow is in the top 4% of the entire breed for lowest Maintenance Energy requirement.**

Calving Ease

The Red Angus Calving Ease EPD was introduced in 2003, and is a more direct measure of calving ease than birth weight alone. Calving Ease is defined as follows: "The expected differences of calving ease measured as the probability difference (between sires) of unassisted calvings among offspring." For Calving Ease EPD, the higher number is better.

There are two Calving Ease EPDs – "Direct", a predictor of an animal's own offspring; and "Maternal", a predictor of a daughter's calving ease. Unless stated otherwise, we publish the Calving Ease Direct because most of our customers' primary concern is selecting bulls for use on first calf heifers.

Beckton's average Calving Ease EPD is +13, seven points higher than the Red Angus breed average of 6, due to our long history of selection for moderate birth weights. **The average Beckton bull is in the top 4% of the entire breed for highest Calving Ease.**

Cow Efficiency

We present two indicators of efficiency. The first is Weaning Percent, a simple percentage of calf 205 day weight divided by the dam's actual weight at weaning. The second is PRI Cow Efficiency. This also measures calf weaning weight, but relative to the cow's metabolic weight, and is expressed as an index above or below 100.

These efficiency measures are best used as indicators of where an animal is relative to others, rather than directly for selection. For example, if we see an animal with a low efficiency, we would look at the actual calf and cow weights to decide if the calf is too small, or the cow too big for the environment. That in turn will suggest corrective actions. **In general, select for the traits you need to change to make cattle more efficient, and efficiency will be the result.**

After 64 years of this performance selection, we believe our cattle are the most efficient in the industry.



Dam Information

A significant difference with our catalog is the greater amount of information about the dams we provide. Weaning percent and Cow Efficiency are explained above. In addition and next to each sale animal, we give the dam's age when that calf was born, and the dam's actual weight when the calf was weaned last fall. We also provide her progeny averages – the average birth weight, weaning ratio, and yearling ratio, of her calves.



Sal Forbes inducted into portrait gallery

Sarah "Sal" Forbes of Sheridan was honored as the first woman inducted into the Saddle and Sirloin Club's portrait gallery at a November 16 ceremony. The presentation was at the Executive West Hotel during the North American International Livestock Exposition on November 8-21 in Louisville, Kentucky.

Forbes was recognized as a "significant, historical, and influential leader in the livestock industry," according to the Saddle and Sirloin Club.

Each year an industry leader is selected by peers to be inducted into the portrait collection.

About 100 letters were received on behalf of Forbes for induction into the gallery, according to Forbes.

"Everybody did a lot of work to make it happen," said Forbes.

The Forbes family owns Beckton Stock Farm in Sheridan, home of the foundation Red Angus breed.

"Her (Forbes) accomplishments in beef production, livestock organization leadership and general influence on the livestock industry are numerous," according to Dorothy Spencer of NAILE.

As for being the first woman inductee, Forbes said it was very exciting.

"They got brave enough to try a woman," she said of the gallery that features more than 340 portraits.

Overall, Forbes said the honor was "humbling."

"A lot of people wrote for me - a great many people," she said.

The program included a presentation of Forbes' biography, her influence on

youth, the impact of the Beckton herd on the industry, and Forbes as a role model, among other topics.

Portrait artist Richard Halstead spent a week with Forbes in Sheridan as he worked on the portrait.

The portrait was hung "with a time-honored ceremony reflecting the tradition of artistic quality and great sentimental and historical value," according to the Saddle and Sirloin Club.

The Saddle and Sirloin Club's portrait gallery was established in 1903. Portraits hang in the gallery at the exposition center, the largest gallery of portraits devoted to a single industry, according to the Saddle and Sirloin Club.

- reprinted from the Sheridan Press

The Other Friends and Family who help us in many ways over the course of the year



Dave Nelson



Stephen Forbes and Elaine Bourne



Sarah, Ellen, Julia, and Katie Durkin



Keenan Forbes and Kara Crawford



Ed Waddington and Julia Forbes



Roger Zier



Spike with Julia Durkin



Elfie Forbes



Ruth Sylvester



Doug Foster and Sarah Forbes



Kate and Don Bingham



Mary Ellen McWilliams, Joy Miller, and Mary Nelson

• Bulls •



Beckton Juniper T826 - Lot 1

1 BECKTON JUNIPER T826

1-A 100% # 1179117 Tattoo: BKT7 T826

Birth: 4-24-07
 Beckton Julian G2 M345
 Beckton Lana H544 WR
BECKTON JUNIPER P381
 Ref. J Beckton Encino M723 JL
 Beckton Julian GG B571
 Beckton Encino J850 CR
 Beckton Warrior TD L493
 Beckton Warrior T C371
BKT PINE MARIE N582 WR
 BKT Pine Marie L650 EP
 Beckton Epic K F075
 BKT Pine Marie H175 NP

DAM		Calv.Ease	BW	WW	YW	Milk	HPG	Stay	Maint.En.
Age	4	10	+1.4	36	68	9	11	16	-3.7
Wt	1125								
Prog.BW	68								
WR	107								
YR	108								
Wean Pct.	54%								
Cow Eff.	114								
		BWt	WWt	WR	ADG	YWt	YR	Scr.	Fr.
		89	639	125	4.14	1241	119	37	5.0

T826 was a feature herd sire prospect in last year's catalog. He attracted a lot of interest, but we pulled him before the sale due to a question of health. It turns out his health is just fine. We have frozen semen on him over the past year, but he has not been with cows. He had the largest Rib-eye measured -- 16.5 -- of any bull on test. For those who want an outstanding beef package and gaining machine with a moderate frame and very low Maintenance EPD, this is the bull. **Selling ½ Interest & Full Possession.**

2 BECKTON JUSTICE U782 C1

1-A 100% # 1259482 Tattoo: BKT8 U782

Birth: 4-14-08
 Beckton Justice CH M056
 Beckton Justice C K449
 Beckton Ruth K802 HD
BECKTON JUSTICE C1 R483
 Ref. J-7 Beckton Tamara J124 HR
 Beckton Herald F FA20
 Beckton Tamara F183 CT
 Beckton Loki C M740
 Beckton Loki F251
BECKTON MAIATA P066 LO
 Beckton Maiata M854 JC
 BKT Larkeisa J051 CK
 Beckton Justice G302
 Beckton Maiata C997 CB

DAM		Calv.Ease	BW	WW	YW	Milk	HPG	Stay	Maint.En.
Age	4	12	-1.9	37	74	13	11	13	-3.5
Wt	940								
Prog.BW	69								
WR	108								
YR	111								
Wean Pct.	71%								
Cow Eff.	149								
		BWt	WWt	WR	ADG	YWt	YR	Scr.	Fr.
		74	686	112	4.03	1240	112	42	5.5

Half brother to last year's phenomenal sale-topping Lot 11 Justice-sired bull. Justice U782 packs impressive growth, together with leading Low Maintenance, Calving Ease and Stayability. For breeders looking to downsize their cows without losing any other traits, this Beckton Maiata dam has efficiency performance off the top of the charts -- a 940 pound dam just four years old, producing a 686 pound weaning, 1240 pound yearling, 42 cm scrotal bull. **Selling ½ Interest & Full Possession.**

3 BECKTON JULIAN U223 GJ

1-A 100% # 1259486 Tattoo: BKT8 U223

Birth: 3-13-08
 Beckton Julian 7526G
 Beckton Julian 6592
 Bkt Belga 6746 GS
BECKTON JULIAN GJ P535
 Ref. J-5 Beckton Mona D086 JL
 Beckton Julian GV Z693
 Beckton Mona 9356 KR
 Beckton Neptune R2 K065
 Beckton Neptune RR B284
BECKTON LARKEISA P136 NP
 Bkt Larkeisa G448 CT
 Beckton Lana C735 TP
 Beckton Clifftop T C075
 Bkt Larkeisa C894 JV

DAM		Calv.Ease	BW	WW	YW	Milk	HPG	Stay	Maint.En.
Age	4	13	-3.0	35	68	11	13	14	-1.7
Wt	1050								
Prog.BW	77								
WR	115								
YR	111								
Wean Pct.	66%								
Cow Eff.	140								
		BWt	WWt	WR	ADG	YWt	YR	Scr.	Fr.
		75	716	117	4.44	1247	112	37	5.5

This is one of Mitch Ziebell's top picks for phenotype. His grandsire is Beckton Julian 7526G, sire of Julian B571. Great bulls come from great cows, and Julian's dam is young, but her first three calves ratioed 119, 110, and 117 at weaning, 110, 110, and 112 at yearling. Lot 3 epitomizes our program that combines growth 12 points higher than breed average with high Calving Ease and low Maintenance EPDs, both in the top 5% of the breed. **Selling ½ Interest & Full Possession.**

We think this is an outstanding offering of bulls and heifers, combining calving ease, fertility, rapid early growth, carcass quality, and breed-leading genetics for reducing cowherd feed needs.

You will find a bigger percentage of the bulls in this sale with genetics for reducing maintenance energy requirements, than in any other major Red Angus sale. And you will find a larger number of bulls that combine both low maintenance energy needs, together with above average growth. The average Yearling Weight EPD of the sale bulls is +58, more than the Red Angus breed average. And notice the incredible spreads combining high growth with low maintenance in bulls such as Lots 1, 2, 3, 4, 5 and many others all through the catalog.

This year Mitch Ziebell, who manages the bulls on test, gave us his appraisal of phenotype, and we have noted some of his top picks.

4 BECKTON JUSTICE U199 CH

1-A 100% # 1258829 Tattoo: WF8 U199

Birth: 3-12-08
 Beckton Justice C K449
 Beckton Justice G302
 Bkt Larkabel C742 CF
BECKTON JUSTICE CH M056
 Ref. J-3 Beckton Ruth K802 HD
 Beckton Hadrian F C486
 Beckton Ruth G534 NP
 RDD B Topper 1675
 Bieber Topper 2476
BECKTON LANA E136 TP
 Beckton Lana 9714 LS
 RR Miss Dynamo 7202
 Beckton Laser 8915
 Beckton Lana 9077 DT

DAM		Calv.Ease	BW	WW	YW	Milk	HPG	Stay	Maint.En.
Age	13	9	-0.1	32	66	11	10	9	-4.6
Wt	1115								
Prog.BW	71								
WR	104								
YR	103								
Wean Pct.	54%								
Cow Eff.	114								
		BWt	WWt	WR	ADG	YWt	YR	Scr.	Fr.
		86	625	107	4.69	1241	114	39	5.0

Lot 4 about matches Lot 3 for performance, with an even lower Maintenance Energy EPD of -5 (top 1% of the breed). Only he comes from a great old dam rather than a great young one. Lana is a cow line you see a lot in these top bulls, and E136 is calving this spring for us at 14 years of age, having never missed a calf and with an average calving date of March 18. Justice is another of Mitch's top picks for phenotypic excellence. **Selling ½ Interest & Full Possession.**

• Bulls •

5 **BECKTON JULIAN U603 GG**
1-A 100% # 1259450 Tattoo: BKT8 U603

Birth: 3-28-08

Beckton Julian 7526G
BECKTON JULIAN GG B571
Ref. J-1 Bkt Marta 9A13 JL

Beckton Laramie L044
BECKTON RUTH N010 LM
Beckton Ruth L277 VG

Beckton Julian 6592
Bkt Belga 6746 GS
Beckton Julian 7526G
Bkt Marta 6498 XM
Beckton Lancer T4 J536
Beckton Sierra J659 DM
Beckton Vegas SC H209
Beckton Ruth G534 NP

DAM		Calv.Ease	BW	WW	YW	Milk	HPG	Stay	Maint.En.
Age	5	16	-3.3	33	61	16	12	16	-1.5
Wt	1115								
Prog.BW	71								
WR	96								
YR	106								
Wean Pct.	60%								
Cow Eff.	126								
		Marb			REA				Bfat
		BWt	WWt	WR	ADG	YWt	YR	Scr.	Fr.
		75	669	109	4.18	1177	106	34	5.0



Beckton Julian GG B571, Ref. J-1
Sire of Lots 5, 6, and 7.

Julian B571 has probably produced as many great herd sires for breeders as any sire existing. His semen hasn't been on the market for many years, and sons are very rare. If you haven't had a B571, this is the opportunity. U603 leads off three top B571 herd sire prospects. Calving ease, growth, milk, carcass and low maintenance EPD's are excellent. His ultrasound ratios are excellent also -- 102 for rib-eye and 117 for marbling. **Selling ½ Interest & Full Possession.**



TR Lana G760
Dam of Lots 6 and 7

7 **TR JULIAN UT816**
1-A 100% # 1240448 Tattoo: TR2A8 UT81

Birth: 2-21-08

BKT Julian 7526 G
BECKTON JULIAN GG B571
Ref. J-1 BKT Marta 9A13 JL

Beckton Cody V E023
TR LANA G760
Beckton Lana E828 SC

Beckton Julian 6592
BKT Belga 6746 GS
BKT Julian 7526 G
BKT Marta 6498 XM
Beckton Cody C401
Beckton Birdie C353 VG
Beckton Scamp 8954
Beckton Lana B695 SG

DAM		Calv.Ease	BW	WW	YW	Milk	HPG	Stay	Maint.En.
Age	11	19	-4.1	29	55	16	15	16.5	-2.3
Wt	NA								
Prog.BW	77								
WR	109								
YR	105								
Wean Pct.	NA%								
Cow Eff.	NA								
		Marb			REA				Bfat
		BWt	WWt	WR	ADG	YWt	YR	Scr.	Fr.
		84	579	NA	3.13	1080	NA	37	5.5

Like his full brother and flushmate, Lot 7 is a rare full brother to TR Julian LT142. The high Stayability EPD of these Julians attests to their high fertility and desirable breeding traits. Calving ease is also among the breed's highest, and growth and milk are excellent. **Selling ½ Interest & Full Possession.**

6 **TR JULIAN UT811**
1-A 100% # 1240429 Tattoo: TR2A8 UT81

Birth: 2-29-08

BKT Julian 7526 G
BECKTON JULIAN GG B571
Ref. J-1 BKT Marta 9A13 JL

Beckton Cody V E023
TR LANA G760
Beckton Lana E828 SC

Beckton Julian 6592
BKT Belga 6746 GS
BKT Julian 7526 G
BKT Marta 6498 XM
Beckton Cody C401
Beckton Birdie C353 VG
Beckton Scamp 8954
Beckton Lana B695 SG

DAM		Calv.Ease	BW	WW	YW	Milk	HPG	Stay	Maint.En.
Age	11	19	-4.1	29	55	16	15	16.5	-2.3
Wt	NA								
Prog.BW	77								
WR	109								
YR	105								
Wean Pct.	NA%								
Cow Eff.	NA								
		Marb			REA				Bfat
		BWt	WWt	WR	ADG	YWt	YR	Scr.	Fr.
		70	658	NA	3.27	1181	NA	34	5.0

Lots 6 and 7 are rare full brothers of TR Julian LT142. Full sisters to both bulls recently sold at the Bet on Red and NILE sales at very respectable prices. They are great ambassadors for the classic Julian traits of calving ease, growth, low maintenance, high heifer pregnancy, stayability, and carcass. **Selling ½ Interest & Full Possession.**



Sue and Forest Dunning
Tongue River Red Angus, 307.750.2454

8 BECKTON JULIAN U357 GJ

1-A 100% # 1259377 Tattoo: BKT8 U357

Birth: 3-18-08

Beckton Julian 7526G
BECKTON JULIAN GJ P535
 Ref. J-5 Beckton Mona D086 JL

Beckton Hadrian A100
BECKTON FIREFLY H195 HD
 Beckton Firefly C999 CB

Beckton Julian 6592
 Bkt Belga 6746 GS
 Beckton Julian GV Z693
 Beckton Mona 9356 KR
 Beckton Julian GN 9A45
 Bkt Marta 9A13 JL
 Beckton Cobalt K Z100
 Bkt Firefly 7252 GS

DAM		Calv.Ease	BW	WW	YW	Milk	HPG	Stay	Maint.En.
Age	10	15	-3.9	24	53	9	15	15	-3.3
Wt	1065								
Prog.BW	70								
WR	102								
YR	101								
Wean Pct.	57%								
Cow Eff.	119								
		Marb	+0.14		REA	+0.11		Bfat	-0.01
		BWt	WWt	WR	ADG	YWt	YR	Scr.	Fr.
		75	604	104	4.49	1173	107	37	5.5

Half brother to Lot 3, Julian has one of the highest ultrasound scans in the sale, with a rib-eye of 101 and marbling ratio of 135. He was a high pick of Mitch's for phenotype, and is a sire for the cattleman wanting very low maintenance, moderate size, calving ease, and longevity in the cowherd. **Selling ½ Interest & Full Possession.**



9 BECKTON WARRIOR U578 T3

1-A 100% # 1259016 Tattoo: WF8 U578

Birth: 3-26-08

Beckton Warrior T1 H281
BECKTON WARRIOR N645 T1
 Ref. W-1 Beckton Rose H074 EP

Beckton Cody KH M390
BECKTON BELGA R083 CD
 Beckton Belga HC71 CB

Beckton Warrior TC E801
 Beckton Minerva B609 RN
 Beckton Epic K F075
 Beckton Rose F791 EM
 Beckton Cody K G701
 Beckton Tamara J124 HR
 Beckton Cobalt V AC03
 Beckton Belga 9582VC

DAM		Calv.Ease	BW	WW	YW	Milk	HPG	Stay	Maint.En.
Age	3	6	+1.0	40	82	14	11	10	+4.8
Wt	1185								
Prog.BW	82								
WR	111								
YR	118								
Wean Pct.	50%								
Cow Eff.	105								
		Marb	+0.05		REA	+0.02		Bfat	+0.01
		BWt	WWt	WR	ADG	YWt	YR	Scr.	Fr.
		82	633	111	5.20	1270	118	39	6.5

Warrior N645 has impressed everyone who has ever used him, with the excellence of his calves. He packs a lot more growth into his calves than most, and with a Yearling Weight EPD of +82, will put pounds on the ground. Another of the high picks for phenotype. Since Warrior is no longer living, his sons will become increasingly rare. **Selling ½ Interest & Full Possession.**

10 BECKTON NEBULA U280 N

1-A 100% # 1258924 Tattoo: WF8 U280

Birth: 3-15-08

Beckton Nebula M045
BECKTON NEBULA N R573
 Ref. N-5 Beckton Lana M621 LN

Andras Pure Gold 132
BECKTON ENCINO N076 PG
 Beckton Encino L922 CH

Beckton Neptune R2 K065
 Beckton Belga K285 JL
 Beckton Lancer F442 T
 Beckton Lana H329 HD
 Badlands Mr Beef 805
 JHL D5803
 Beckton Champ R3 H338
 Beckton Encino G341 NP

DAM		Calv.Ease	BW	WW	YW	Milk	HPG	Stay	Maint.En.
Age	5	9	+0.6	45	77	15	9	13	+0.7
Wt	1195								
Prog.BW	73								
WR	110								
YR	109								
Wean Pct.	61%								
Cow Eff.	128								
		Marb	+0.07		REA	+0.02		Bfat	-0.01
		BWt	WWt	WR	ADG	YWt	YR	Scr.	Fr.
		90	726	118	3.88	1270	115	41	5.5

★★★★ for Low Maintenance, Growth, Superior Cow, High Cow Efficiency, Calving Ease, Stayability. **Selling ½ Interest & Full Possession.**

11 BECKTON EPIC U768 K4

1-A 100% # 1259471 Tattoo: BKT8 U768

Birth: 4-12-08

Beckton Epic KJ J722
BECKTON EPIC K4 N795
 Ref. E-2 Beckton Sierra J789 EP

Beckton Hustler CN J102
BECKTON VERNICE N598 HU
 Beckton Vernice C047 JL

Beckton Epic K F075
 Beckton Lana F891 JL
 Beckton Epic D404
 Beckton Sierra C157 CL
 Beckton Hustler C G407
 Beckton Belga G355 NP
 Beckton Julian SJ A470
 Beckton Vernice A140 JU

DAM		Calv.Ease	BW	WW	YW	Milk	HPG	Stay	Maint.En.
Age	5	8	-0.7	37	85	14	10	9	+1.5
Wt	1185								
Prog.BW	73								
WR	113								
YR	114								
Wean Pct.	57%								
Cow Eff.	119								
		Marb	+0.05		REA	+0.13		Bfat	-0.01
		BWt	WWt	WR	ADG	YWt	YR	Scr.	Fr.
		81	672	109	4.80	1283	116	36	5.0

★★★★ for Low Maintenance, Growth, Gainability, Rib-eye area, Superior Cow, High Cow Efficiency, Calving Ease. **Selling ½ Interest & Full Possession.**

12 TR JUBILATION UT800

1-A 100% # 1240403 Tattoo: TR2A8 UT80

Birth: 2-25-08

Beckton Julian GG B571
TR JULIAN LT142
 Ref. J-10 TR Lana G760

Beckton Lancer T A664
TR LYDIA G750
 Beckton Lydia E251 CL

BKT Julian 7526 G
 BKT Marta 9A13 JL
 Beckton Cody V E023
 Beckton Lana E828 SC
 Beckton Lancer 9380
 Beckton Coca 9119 TJ
 Beckton Clipper ER C360
 Beckton Lydia C180 CF

DAM		Calv.Ease	BW	WW	YW	Milk	HPG	Stay	Maint.En.
Age	11	15	-0.4	42	75	13	13	13.8	+5.2
Wt	NA								
Prog.BW	77								
WR	105								
YR	105								
Wean Pct.	NA%								
Cow Eff.	NA								
		Marb	+0.09		REA	+0.21		Bfat	+0.00
		BWt	WWt	WR	ADG	YWt	YR	Scr.	Fr.
		84	704	115	3.55	1273	114	38	6.0

A son of TR Julian LT142 and a very productive Lydia dam (MPPA 104.3), Lot 2 has all the calving ease and carcass that one can expect with such high performance numbers. He gained 4.6 lbs. per day on test and ratioed 115 at weaning and 114 at yearling. He scores in the top 15th percentile for eight of the thirteen measured EPD's. **Selling ½ Interest & Full Possession.**

• Bulls •



13 BECKTON ROMAN U035 J
1-A 100% # 1259636 Tattoo: BKT8 U035

Birth: 2-21-08
 / TR Romeo NT379 < Buffalo Creek Romeo L081
 / Buf Crk Lass L420
BECKTON ROMAN J S158
 Ref. J-9 < Beckton Julian GG B571
 < Beckton Belga K285 JL < Beckton Belga G493 HR
 < Beckton Hawk P248 < Beckton Hustler C2 L079
BECKTON SIERRA S120 HW
 < Beckton Lana L498 CO
 < Beckton Sierra P348 JO < Beckton Julio L233
 < Beckton Sierra J659 DM

DAM		Calv.Ease	BW	WW	YW	Milk	HPG	Stay	Maint.En.
Age	2	9	-0.1	40	73	19	10	15	-3.6
Wt	790	Marb +0.2		REA +0.28		Bfat +0.1			
Prog.BW	73	BWt	WWt	WR	ADG	YWt	YR	Scr.	Fr.
WR	109	73	586	109	3.93	1113	110	33	5.5
YR	110								
Wean Pct.	67%								
Cow Eff.	140								

★★★★★ for Low Maintenance, Growth, Rib-eye area, Superior Cow, High Cow Efficiency, Calving Ease, Stayability. **Selling ½ Interest & Full Possession.**

14 BECKTON LANCER U609 TD
1-A 100% # 1258876 Tattoo: WF8 U609

Birth: 3-28-08
 / Beckton Lancer T A664 < Beckton Lancer 9380
 < Beckton Coca 9119 TJ
BECKTON LANCER F442 T
 Ref. L-1 < Beckton Dominor 9455
 < Bkt Suffeina A828 DM < Bkt Suffeina 9493 TT
 < Beckton Julian 7526G < Beckton Julian 6592
BECKTON BELGA K476 JL
 < Bkt Belga 6746 GS
 < Beckton Vegas 9433
 < Beckton Belga F772 VG < Beckton Belga A750 SN

DAM		Calv.Ease	BW	WW	YW	Milk	HPG	Stay	Maint.En.
Age	8	12	-2.0	28	49	11	8	13	-2.9
Wt	1230	Marb +1.2		REA +0.29		Bfat -0.1			
Prog.BW	67	BWt	WWt	WR	ADG	YWt	YR	Scr.	Fr.
WR	106	74	636	104	3.98	1135	102	39	5.0
YR	102								
Wean Pct.	52%								
Cow Eff.	109								

★★★★★ for Low Maintenance, Marbling, Rib-eye area, Calving Ease, Stayability. **Selling ½ Interest & Full Possession.**

15 BECKTON CHEROKEE U573 N
1-A 100% # 1259404 Tattoo: BKT8 U573

Birth: 3-26-08
 / BFCK Cherokee Cnyn 4912 < BUF CRK Chief 824-1658
 < MRM 1431 8611 9109
BECKTON CHEROKEE N N479
 Ref. B-1 < Beckton Nomad K 9949
 < Beckton Dinah C440 NM < Beckton Dinah Z610 JL
 < Beckton Lancer T4 J536 < Beckton Lancer TZ D525
BECKTON ROSE L083 LN
 < Beckton Vernice D121 VG
 < Beckton Lancer TZ D525
 < Beckton Rose J152 LN < Beckton Rose D379 CB

DAM		Calv.Ease	BW	WW	YW	Milk	HPG	Stay	Maint.En.
Age	7	14	-2.7	38	55	15	8	11	-4.2
Wt	1020	Marb +1.6		REA +0.08		Bfat +0.1			
Prog.BW	68	BWt	WWt	WR	ADG	YWt	YR	Scr.	Fr.
WR	101	72	688	112	4.03	1127	102	36	5.0
YR	98								
Wean Pct.	68%								
Cow Eff.	142								

★★★★★ for Low Maintenance, Gainability, Marbling, High Cow Efficiency, Calving Ease.

16 BECKTON JUSTICE U300 CH
1-A 100% # 1258874 Tattoo: WF8 U300

Birth: 3-16-08
 / Beckton Justice C K449 < Beckton Justice G302
 < Bkt Larkabel C742 CF
BECKTON JUSTICE CH M056
 Ref. J-3 < Beckton Ruth K802 HD
 < Beckton Hadrian F C486
 < Beckton Ruth G534 NP
 < Beckton Copper JT G095 < Beckton Copper J E616
BECKTON ANGEL K360 CO
 < Beckton Ruth E549 TP
 < Beckton Vegas P D462
 < Beckton Angel F717 VG < Beckton Angel D665 VG

DAM		Calv.Ease	BW	WW	YW	Milk	HPG	Stay	Maint.En.
Age	8	6	+2.1	39	78	15	10	12	-2.1
Wt	1265	Marb +1.2		REA +0.02		Bfat -0.1			
Prog.BW	76	BWt	WWt	WR	ADG	YWt	YR	Scr.	Fr.
WR	108	95	644	110	4.90	1256	115	36	6.0
YR	110								
Wean Pct.	51%								
Cow Eff.	107								

Bulls with high birth weights tend to be outliers in our program, but Lot 16 and the two bulls to follow are very unusual in that they combine breed-leading growth with low maintenance requirements. For the cattleman who doesn't need the lowest calving ease, but wants to lower cowherd maintenance costs while building growth, Lot 16, 17, and 18 are bulls to latch on to. **Selling ½ Interest & Full Possession.**

17 BECKTON ROMAN U020 J
1-A 100% # 1259644 Tattoo: BKT8 U020

Birth: 2-17-08
 / TR Romeo NT379 < Buffalo Creek Romeo L081
 < Buf Crk Lass L420
BECKTON ROMAN J S158
 Ref. J-9 < Beckton Julian GG B571
 < Beckton Belga K285 JL < Beckton Belga G493 HR
 < Beckton Hawk P248 < Beckton Hustler C2 L079
BKT PINE MARIE S193 HW
 < Beckton Lana L498 CO
 < Beckton Lancer T4 J536
 < BKT Pine Marie P638 LN < BKT Pine Marie J556 EP

DAM		Calv.Ease	BW	WW	YW	Milk	HPG	Stay	Maint.En.
Age	2	4	+4.2	51	87	18	9	15	-1.1
Wt	865	Marb +0.5		REA +0.30		Bfat +0.1			
Prog.BW	94	BWt	WWt	WR	ADG	YWt	YR	Scr.	Fr.
WR	118	94	629	118	4.18	1154	114	37	6.0
YR	114								
Wean Pct.	66%								
Cow Eff.	139								

★★★★★ for Low Maintenance, Growth, Gainability, Rib-eye area, Superior Cow, High Cow Efficiency, Stayability. **Selling ½ Interest & Full Possession.**

• Bulls •

18 **BECKTON EPIC U604 KJ**
1-A 100% # 1258892 Tattoo: WF8 U604

Birth: 3-28-08
 Beckton Epic K F075
BECKTON EPIC KJ J722
 Ref. Beckton Lana F891 JL
 Beckton Epic D404
 Beckton Belga D483 KR
 Beckton Clifftop T C075
 Beckton Lana 9610 TP
 LCC Heaven or Bust 1000B
 Beckton Rose E032 CL
 Beckton Lancer TZ D525
 Beckton Ucola C629 JL
BECKTON UCOLA L781 HU
 Beckton Hustler C G407
 Beckton Ucola HA24 LN

DAM		Calv.Ease	BW	WW	YW	Milk	HPG	Stay	Maint.En.
Age	7	5	+3.7	43	72	14	11	9	-2.6
Wt	1160	Marb +.20		REA +.07		Bfat -.01			
Prog.BW	73	BWt	WWt	WR	ADG	YWt	YR	Scr.	Fr.
WR	105	95	695	119	4.03	1219	112	35	5.5
YR	106								
Wean Pct.	60%								
Cow Eff.	126								

★★★★ for Low Maintenance, Growth, Gainability, Marbling, Superior Cow, High Cow Efficiency. **Selling ½ Interest & Full Possession.**

21 **BECKTON JULIAN U555 G2**
2 100% # 1259056 Tattoo: WF8 U555

Birth: 3-25-08
 Beckton Julian GG B571
BECKTON JULIAN G2 M345
 Ref. Beckton Lana H544 WR
 Beckton Julian 7526G
 Bkt Marta 9A13 JL
 Beckton Warrior TC E801
 Beckton Lana E545 CL
 Beckton Julian G1 J526
 Beckton Barona J591 EP
 Beckton Epic KJ J722
 Beckton Barmaid H225 HD
BECKTON BARMAID R542 JE
 Beckton Jules L429
 Beckton Barmaid M296 EP

DAM		Calv.Ease	BW	WW	YW	Milk	HPG	Stay	Maint.En.
Age	3	15	-2.0	29	67	14	10	14	-6.4
Wt	955	Marb +.11		REA +.22		Bfat +.00			
Prog.BW	63	BWt	WWt	WR	ADG	YWt	YR	Scr.	Fr.
WR	116	74	671	116	4.54	1250	116	36	5.5
YR	116								
Wean Pct.	66%								
Cow Eff.	139								

★★★★ for Low Maintenance, Growth, Gainability, Marbling, Rib-eye area, Superior Cow, High Cow Efficiency, Calving Ease, Stayability.

19 **TR RICARDO UT825**
1-A 100% # 1240477 Tattoo: TR2A8 UT82

Birth: 3-16-08
 BFCK Cherokee Cnyn 4912
TR RICARDO RT574
 Ref. B-5 TR Dyna LT111
 Beckton Julian GG B571
 BKT Julia 7526 G
 BKT Marta 9A13 JL
 Farn Red Quinn 315
 FN Lear 4700-5110
ODC PAMELA P19
 ODC Ann

DAM		Calv.Ease	BW	WW	YW	Milk	HPG	Stay	Maint.En.
Age	4	14	-2.1	33	61	16	10	15.5	-5.0
Wt	NA	Marb +.09		REA +.33		Bfat +.00			
Prog.BW	75	BWt	WWt	WR	ADG	YWt	YR	Scr.	Fr.
WR	101	85	637	104	3.43	1185	107	33	6.0
YR	103								
Wean Pct.	NA%								
Cow Eff.	NA								

★★★★ for Low Maintenance, Growth, Rib-eye area, Calving Ease, Stayability. **Selling ½ Interest & Full Possession.**

22 **BECKTON EPIC U430 KM**
1-A 100% # 1258880 Tattoo: WF8 U430

Birth: 3-21-08
 Beckton Epic K F075
BECKTON EPIC KM M115
 Ref. E-1 Beckton Minerva F495 CH
 Beckton Epic D404
 Beckton Belga D483 KR
 Beckton Champ R A583
 Beckton Minerva CB69 JL
 Bkt Clifftop TV G672
 Beckton Mona G569 CS
 Beckton Champ RK E121
 Beckton Tamara D359 SC
BECKTON TAMARA L132 CT
 BKT Clifftop T2 J059
 Beckton Tamara J201 CH

DAM		Calv.Ease	BW	WW	YW	Milk	HPG	Stay	Maint.En.
Age	7	8	-0.7	40	77	22	6	11	+1.9
Wt	1170	Marb +.02		REA -.08		Bfat +.01			
Prog.BW	75	BWt	WWt	WR	ADG	YWt	YR	Scr.	Fr.
WR	107	81	692	119	3.88	1235	113	37	5.5
YR	106								
Wean Pct.	59%								
Cow Eff.	125								

★★★★ for Low Maintenance, Growth, Superior Cow, High Cow Efficiency, Calving Ease.

20 **TR JULIAN UT824**
1-A 100% # 1240464 Tattoo: TR2A8 UT82

Birth: 3-7-08
 Beckton Julian GG B571
TR JULIAN LT151
 Ref. J-11 MS Geometric 917
 Beckton Epic D404
 Beckton Saga KJ B702
 Beckton Kuruba B508 PC
 Beckton Lancer F134 TS
 Beckton Lana E828 SC
TR LANA NT329
 TR Lana LT116

DAM		Calv.Ease	BW	WW	YW	Milk	HPG	Stay	Maint.En.
Age	5	13	-3.3	27	58	14	12	15.4	+1.7
Wt	NA	Marb +.21		REA +.19		Bfat +.01			
Prog.BW	77	BWt	WWt	WR	ADG	YWt	YR	Scr.	Fr.
WR	105	80	631	103	3.42	1177	106	36	5.0
YR	106								
Wean Pct.	NA%								
Cow Eff.	NA								

★★★★ for Low Maintenance, Marbling, Rib-eye area, Superior Cow, Calving Ease, Stayability. **Selling ½ Interest & Full Possession.**



23 BECKTON JULIAN U485 GJ

1-A 100% # 1258893 Tattoo: WF8 U485

Birth: 3-23-08

Beckton Julian 7526G
BECKTON JULIAN GJ P535
 Ref. J-5
 Beckton Mona D086 JL
 Beckton Julian 6592
 Bkt Belga 6746 GS
 Beckton Julian GV Z693
 Beckton Mona 9356 KR
 Beckton Cody K G701
BECKTON ENCINO L797 CD
 Beckton Encino A168 JU
 Beckton Cody C401
 Beckton Christy B007 KR
 Beckton Julius 9A07
 Bkt Encino 9A98 PC

DAM		Calv.Ease	BW	WW	YW	Milk	HPG	Stay	Maint.En.
Age	7	12	-2.6	33	60	6	10	13	-2.8
Wt	1135	Marb +0.05		REA +0.04		Bfat +0.01			
Prog.BW	71	BWt	WWt	WR	ADG	YWt	YR	Scr.	Fr.
WR	103	82	655	112	4.03	1169	107	41	5.5
YR	102								
Wean Pct.	58%								
Cow Eff.	122								

★★★★★ for Low Maintenance, Gainability, High Cow Efficiency, Calving Ease, Stayability.

26 BECKTON EPIC U241 K4

1-A 100% # 1259442 Tattoo: BKT8 U241

Birth: 3-14-08

Beckton Epic KJ J722
BECKTON EPIC K4 N795
 Ref. E-2
 Beckton Sierra J789 EP
 Beckton Epic K F075
 Beckton Lana F891 JL
 Beckton Epic D404
 Beckton Sierra C157 CL
 Beckton Warrior C C355
BECKTON LARKABA M715 WR
 Beckton Larkaba D388 SC
 Beckton Epic K F075
 Beckton Lana F891 JL
 Beckton Epic D404
 Beckton Sierra C157 CL
 JKG Chiefton L303
 Bkt Christy 9A01 CL
 Beckton Scamp T A825
 Beckton Larkaba A833 JL

DAM		Calv.Ease	BW	WW	YW	Milk	HPG	Stay	Maint.En.
Age	6	10	-0.4	33	70	12	9	9	-2.8
Wt	1110	Marb +0.14		REA +0.05		Bfat +0.01			
Prog.BW	66	BWt	WWt	WR	ADG	YWt	YR	Scr.	Fr.
WR	94	79	625	102	4.34	1153	104	35	5.5
YR	96								
Wean Pct.	56%								
Cow Eff.	119								

★★★★★ for Low Maintenance, Gainability, Marbling, High Cow Efficiency, Calving Ease.

24 BKT CHEROKEE U269 N

1-A 100% # 1259459 Tattoo: BKT8 U269

Birth: 3-15-08

BFCK Cherokee Cnyn 4912
BECKTON CHEROKEE N N479
 Ref. B-1
 Beckton Dinah C440 NM
 BUF CRK Chief 824-1658
 MRM 1431 8611 9109
 Beckton Nomad K 9949
 Beckton Dinah Z610 JL
 Beckton Neptune R2 K065
BECKTON FIREFLY N177 NP
 Beckton Firefly KA56 WR
 Beckton Neptune RR B284
 Beckton Lana C735 TP
 Beckton Warrior B C123
 Beckton Firefly D109 CL

DAM		Calv.Ease	BW	WW	YW	Milk	HPG	Stay	Maint.En.
Age	5	11	-2.5	33	61	15	11	9	-3.0
Wt	1055	Marb +0.07		REA +0.18		Bfat +0.00			
Prog.BW	70	BWt	WWt	WR	ADG	YWt	YR	Scr.	Fr.
WR	104	74	597	102	3.93	1164	107	37	5.5
YR	105								
Wean Pct.	57%								
Cow Eff.	119								

★★★★★ for Low Maintenance, Growth, Rib-eye area, Superior Cow, High Cow Efficiency, Calving Ease. **Selling 1/2 Interest & Full Possession.**

27 BECKTON JET U207 L

1-A 100% # 1259425 Tattoo: BKT8 U207

Birth: 3-12-08

TR Julian LT151
BECKTON JET L P491
 Ref. J-4
 Beckton Minerva L278 LN
 Beckton Julian GG B571
 MS Geometric 917
 Beckton Lancer TS D390
 Beckton Minerva F495 CH
 Beckton Loki F251
BECKTON COCA M080 LO
 Beckton Coca F370 CT
 Beckton Lancer TZ D525
 Bkt Pine Marie D126 JL
 Beckton Clifftop T C075
 Beckton Coca C178 VG

DAM		Calv.Ease	BW	WW	YW	Milk	HPG	Stay	Maint.En.
Age	6	16	-4.7	22	48	16	7	16	-2.8
Wt	1055	Marb +0.13		REA +0.08		Bfat -0.01			
Prog.BW	69	BWt	WWt	WR	ADG	YWt	YR	Scr.	Fr.
WR	104	72	586	101	4.54	1130	104	36	5.0
YR	103								
Wean Pct.	56%								
Cow Eff.	117								

★★★★★ for Low Maintenance, Gainability, Marbling, Superior Cow, High Cow Efficiency, Calving Ease, Stayability.

25 BECKTON NEBULA U674 N

1-A 100% # 1258928 Tattoo: WF8 U674

Birth: 4-2-08

Beckton Nebula M045
BECKTON NEBULA N R573
 Ref. N-5
 Beckton Lana M621 LN
 Beckton Neptune R2 K065
 Beckton Belga K285 JL
 Beckton Lancer F442 T
 Beckton Lana H329 HD
 Beckton Jules L429
BECKTON LARKABA N146 JE
 Beckton Larkaba L316 CT
 Beckton Julian G1 J526
 Beckton Barona J591 EP
 Beckton Clifftop T C075
 Beckton Larkaba H259 CH

DAM		Calv.Ease	BW	WW	YW	Milk	HPG	Stay	Maint.En.
Age	5	15	-4.6	29	59	15	8	14	-4.7
Wt	1005	Marb +0.05		REA +0.10		Bfat -0.01			
Prog.BW	69	BWt	WWt	WR	ADG	YWt	YR	Scr.	Fr.
WR	112	69	656	113	4.59	1215	111	35	5.5
YR	110								
Wean Pct.	65%								
Cow Eff.	138								

★★★★★ for Low Maintenance, Gainability, Superior Cow, High Cow Efficiency, Calving Ease, Stayability.

28 BECKTON NEBULA U470 L

1-A 100% # 1259399 Tattoo: BKT8 U470

Birth: 3-22-08

Beckton Nebula M045
BECKTON NEBULA L P093
 Ref. N-3
 Beckton Marta M021 LN
 Beckton Neptune R2 K065
 Beckton Belga K285 JL
 Beckton Lancer TA K644
 Beckton Marta K254 LN
 Beckton Epic D404
BECKTON LARKABA K530 EP
 Beckton Larkaba F843 JL
 Beckton Saga KJ B702
 Beckton Kuruba B508 PC
 Beckton Julian GG B571
 Beckton Larkaba B445 CB

DAM		Calv.Ease	BW	WW	YW	Milk	HPG	Stay	Maint.En.
Age	8	16	-3.6	31	59	6	9	15	-5.4
Wt	1095	Marb +0.03		REA +0.29		Bfat +0.01			
Prog.BW	59	BWt	WWt	WR	ADG	YWt	YR	Scr.	Fr.
WR	95	68	618	106	3.67	1112	102	35	5.5
YR	96								
Wean Pct.	56%								
Cow Eff.	119								

★★★★★ for Low Maintenance, Rib-eye area, High Cow Efficiency, Calving Ease, Stayability.

• Bulls •

29 **BECKTON JUSTICE U215 CH**
1-A 100% # 1259464 Tattoo: BKT8 U215

Birth: 3-12-08
 Beckton Justice C K449
BECKTON JUSTICE CH M056
 Ref. J-3 Beckton Ruth K802 HD
 Beckton Justice G302
 Bkt Larkabel C742 CF
 Beckton Hadrian F C486
 Beckton Ruth G534 NP
 Beckton Lancer TH K417
 Beckton Angel G356 HR
BECKTON SIERRA N403 LN
 Beckton Sierra J659 DM
 Beckton Dominor ZR G223
 Beckton Sierra G671 DM

DAM		Calv.Ease	BW	WW	YW	Milk	HPG	Stay	Maint.En.
Age	5	9	+0.7	36	71	16	10	11	+1.8
Wt	1185								
Prog.BW	78								
WR	110		Marb	+0.23	REA	+0.10	Bfat	-.02	
YR	110								
Wean Pct.	54%	BWt	WWt	WR	ADG	YWt	YR	Scr.	Fr.
Cow Eff.	114	85	641	104	4.18	1174	106	37	5.0

★★★★★ for Low Maintenance, Growth, Gainability, Marbling, Superior Cow, Calving Ease.



31 **BECKTON NEBULA U403 L**
1-A 100% # 1259480 Tattoo: BKT8 U403

Birth: 3-20-08
 Beckton Nebula M045
BECKTON NEBULA L P093
 Ref. N-3 Beckton Marta M021 LN
 Beckton Neptune R2 K065
 Beckton Belga K285 JL
 Beckton Lancer TA K644
 Beckton Marta K254 LN
 Beckton Loki F251
 BKT Larkeisa J051 CK
BECKTON INDIGO P043 LO
 Beckton Loki C M740
 Beckton Indigo M571 EP
 Beckton Epic K F075
 Beckton Indigo C106 LN

DAM		Calv.Ease	BW	WW	YW	Milk	HPG	Stay	Maint.En.
Age	4	10	.0	40	74	9	9	14	+2.4
Wt	1115								
Prog.BW	78								
WR	112		Marb	+0.10	REA	+0.15	Bfat	-.01	
YR	110								
Wean Pct.	58%	BWt	WWt	WR	ADG	YWt	YR	Scr.	Fr.
Cow Eff.	121	83	662	108	3.83	1197	108	41	5.5

★★★★★ for Low Maintenance, Growth, Rib-eye area, Superior Cow, High Cow Efficiency, Calving Ease, Stayability.

32 **BECKTON NEBULA U565 E**
1-A 100% # 1259479 Tattoo: BKT8 U565

Birth: 3-25-08
 Beckton Nebula M045
BECKTON NEBULA E P084
 Ref. N-2 BKT Pine Marie M119 EP
 Beckton Neptune R2 K065
 Beckton Belga K285 JL
 Beckton Epic K F075
 Bkt Pine Marie D126 JL
 Beckton Lancer T7 M089
BECKTON ROSE P016 LN
 Beckton Rose M131 HR
 Beckton Lancer F442 T
 Beckton Tamara G141 HE
 Beckton Herald HH E503
 Beckton Rose H253 CH

DAM		Calv.Ease	BW	WW	YW	Milk	HPG	Stay	Maint.En.
Age	4	11	-2.3	31	59	13	9	13	-2.3
Wt	1055								
Prog.BW	77								
WR	102		Marb	+0.08	REA	+0.06	Bfat	+0.00	
YR	104								
Wean Pct.	55%	BWt	WWt	WR	ADG	YWt	YR	Scr.	Fr.
Cow Eff.	116	86	601	103	4.44	1139	104	32	5.5

★★★★★ for Low Maintenance, Gainability, High Cow Efficiency, Calving Ease, Stayability.

30 **BECKTON NEBULA U349 L**
1-A 100% # 1258933 Tattoo: WF8 U349

Birth: 3-18-08
 Beckton Nebula M045
BECKTON NEBULA L P093
 Ref. N-3 Beckton Marta M021 LN
 Beckton Neptune R2 K065
 Beckton Belga K285 JL
 Beckton Lancer TA K644
 Beckton Marta K254 LN
 Beckton Justice G302
 Beckton Julian GG B571
 Bkt Vernice 9733 PC
BECKTON LANA N291 JC
 Beckton Lana H725 CH
 Beckton Champ RK E121
 Beckton Lana E937 NM

DAM		Calv.Ease	BW	WW	YW	Milk	HPG	Stay	Maint.En.
Age	5	13	-1.8	39	64	7	11	13	-0.8
Wt	1185								
Prog.BW	73								
WR	105		Marb	+0.18	REA	+0.18	Bfat	-.01	
YR	103								
Wean Pct.	55%	BWt	WWt	WR	ADG	YWt	YR	Scr.	Fr.
Cow Eff.	115	74	647	111	3.06	1115	102	41	5.5

★★★★★ for Low Maintenance, Marbling, Rib-eye area, Superior Cow, Calving Ease, Stayability.

33 **BSF NEBULA U228 L**
2 99% # 1259217 Tattoo: BSF8 U228

Birth: 3-13-08
 Beckton Nebula M045
BECKTON NEBULA L P093
 Ref. N-3 Beckton Marta M021 LN
 Beckton Neptune R2 K065
 Beckton Belga K285 JL
 Beckton Lancer TA K644
 Beckton Marta K254 LN
 BSF Hustler C1 L004
BSF HELENA N024 HU
 BSF Regus L314 WR
 Beckton Hustler CN J102
 BSF Regus J475
 Beckton Warrior T2 J333
 BSF Regus J458

DAM		Calv.Ease	BW	WW	YW	Milk	HPG	Stay	Maint.En.
Age	5	13	-1.4	40	86	10	9	12	+1.3
Wt	1135								
Prog.BW	66								
WR	108		Marb	+0.13	REA	+0.23	Bfat	-.02	
YR	109								
Wean Pct.	56%	BWt	WWt	WR	ADG	YWt	YR	Scr.	Fr.
Cow Eff.	118	74	638	109	5.31	1290	118	38	5.5

★★★★★ for Low Maintenance, Growth, Gainability, Marbling, Rib-eye area, Superior Cow, High Cow Efficiency, Calving Ease. **Selling 1/2 Interest & Full Possession.**

• Bulls •



34 **BSF EPIC U567 K4**
1-B 99% # 1259235 Tattoo: BSF8 U567

Birth: 3-25-08
 ↗ Beckton Epic KJ J722 ↘ Beckton Epic K F075
 ↗ Beckton Lana F891 JL ↘ Beckton Epic D404
BECKTON EPIC K4 N795
 Ref. E-2 ↗ Beckton Sierra J789 EP ↘ Beckton Sierra C157 CL
 ↗ Beckton Copper J E616
BSF BUFFIE N856 CO
 ↗ Beckton Copper JT G095 ↘ Beckton Ruth E549 TP
 ↗ Beckton Caesar M D023
 ↗ BSF Regus F207 ↘ BSF Regus D006

DAM		Calv.Ease	BW	WW	YW	Milk	HPG	Stay	Maint.En.
Age	5	7	+0.4	38	84	18	7	12	+1.2
Wt	1125	Marb +.23		REA +.08		Bfat +.02			
Prog.BW	77	BWt	WWt	WR	ADG	YWt	YR	Scr.	Fr.
WR	109	82	690	118	4.80	1322	121	35	6.0
YR	109								
Wean Pct.	61%								
Cow Eff.	129								

★★★★★ for Low Maintenance, Growth, Gainability, Marbling, Superior Cow, High Cow Efficiency, Calving Ease.

35 **BSF JORDAN U277**
1-B 99% # 1259229 Tattoo: BSF8 U277

Birth: 3-15-08
 ↗ TR Julian LT151 ↘ Beckton Julian GG B571
 ↗ MS Geometric 917
TR JULIAN RT561
 Ref. J-13 ↗ TR Dyna HT824 ↘ Buf Crk Dynamics 3820
 ↘ Buf Crk Dyna 3082
 ↗ Beckton Vegas SV H078
BSF VIOLET N382 VG
 ↗ Beckton Vegas S1 K316 ↘ Beckton Eola H073 EP
 ↗ BSF Casper F784
 ↗ BSF Regus F563

DAM		Calv.Ease	BW	WW	YW	Milk	HPG	Stay	Maint.En.
Age	5	12	-2.0	32	68	12	9	11	+4.3
Wt	1195	Marb +.05		REA +.06		Bfat +.01			
Prog.BW	73	BWt	WWt	WR	ADG	YWt	YR	Scr.	Fr.
WR	99	77	653	112	4.90	1222	112	37	5.5
YR	112								
Wean Pct.	55%								
Cow Eff.	115								

★★★★★ for Growth, Gainability, Calving Ease.

36 **BSF CHEROKEE U236 N**
1-B 99% # 1259182 Tattoo: BSF8 U236

Birth: 3-13-08
 ↗ BFCK Cherokee Cnyn 4912 ↘ BUF CRK Chief 824-1658
 ↗ MRM 1431 8611 9109
BECKTON CHEROKEE N N479
 Ref. B-1 ↗ Beckton Dinah C440 NM ↘ Beckton Nomad K 9949
 ↘ Beckton Dinah Z610 JL
 ↗ Beckton Champ RK E121
BSF REGUS K155 CH
 ↗ Beckton Champ R2 H293 ↘ Beckton Angel 8682SL
 ↗ Beckton Caesar M D023
 ↗ BSF Regus C190

DAM		Calv.Ease	BW	WW	YW	Milk	HPG	Stay	Maint.En.
Age	8	9	-0.3	41	73	19	8	10	+0.8
Wt	1270	Marb +.07		REA +.16		Bfat +.01			
Prog.BW	75	BWt	WWt	WR	ADG	YWt	YR	Scr.	Fr.
WR	107	85	699	114	5.26	1291	116	38	5.5
YR	109								
Wean Pct.	55%								
Cow Eff.	116								

★★★★★ for Low Maintenance, Growth, Gainability, Rib-eye area, Superior Cow, High Cow Efficiency, Calving Ease.

37 **BSF NEBULA U078 PJ**
1-B 99% # 1259348 Tattoo: BSF8 U078

Birth: 2-28-08
 ↗ Beckton Nebula P P707 ↘ Beckton Nebula M045
 ↘ Beckton Lana M809 EP
BECKTON NEBULA PJ S543
 Ref. N-8 ↗ Beckton Lana P685 JO ↘ Beckton Julio L233
 ↘ Beckton Lana E083 CD
 ↗ Beckton Justice C K449
BSF JUSTICIA S777 JC
 ↗ Beckton Justice CH M056 ↘ Beckton Ruth K802 HD
 ↗ Beckton Epic K F075
 ↗ BSF Regus L414 EP ↘ BSF Regus H520

DAM		Calv.Ease	BW	WW	YW	Milk	HPG	Stay	Maint.En.
Age	2	13	-2.7	36	81	12	11	12	-3.9
Wt	845	Marb +.15		REA +.21		Bfat +.01			
Prog.BW	66	BWt	WWt	WR	ADG	YWt	YR	Scr.	Fr.
WR	105	66	595	105	5.71	1216	117	31	6.0
YR	117								
Wean Pct.	63%								
Cow Eff.	133								

★★★★★ for Low Maintenance, Growth, Gainability, Marbling, Rib-eye area, Superior Cow, High Cow Efficiency, Calving Ease. **Selling 1/2 Interest & Full Possession.**

38 **BSF NEBULA U434 L**
1-B 99% # 1259207 Tattoo: BSF8 U434

Birth: 3-21-08
 ↗ Beckton Nebula M045 ↘ Beckton Neptune R2 K065
 ↘ Beckton Belga K285 JL
BECKTON NEBULA L P093
 Ref. N-3 ↗ Beckton Marta M021 LN ↘ Beckton Lancer TA K644
 ↘ Beckton Marta K254 LN
 ↗ Beckton Epic K F075
BSF REGUS M507 EP
 ↗ Beckton Epic K F075 ↘ Beckton Belga D483 KR
 ↗ Beckton Clipper KC D400
 ↗ BSF Regus J119 ↘ BSF Regus C059

DAM		Calv.Ease	BW	WW	YW	Milk	HPG	Stay	Maint.En.
Age	6	8	-0.4	39	78	10	10	11	+1.5
Wt	1240	Marb +.11		REA +.34		Bfat +.01			
Prog.BW	88	BWt	WWt	WR	ADG	YWt	YR	Scr.	Fr.
WR	116	87	659	113	5.15	1253	115	39	5.5
YR	111								
Wean Pct.	53%								
Cow Eff.	112								

★★★★★ for Low Maintenance, Growth, Gainability, Marbling, Rib-eye area, Superior Cow, Calving Ease.

• Bulls •

39 **BSF LIKABLE U005**
1-B 99% # 1259313 Tattoo: BSF8 U005

Birth: 2-11-08
 Beckton Lancer F442 T
BECKTON LIKABLE S633
 Ref. L-4
 Beckton Kit F468 JL
 Beckton Lancer T A664
 Bkt Suffeina A828 DM
 Beckton Julian GG B571
 Beckton Kit A517 NP
 Beckton Cody K G701
 Beckton Tamara J124 HR
 Beckton Colt G552
 BSF Regus Z112
 Beckton Cody KH M390
BSF CODETTE S162 CD
 BSF Regus L632 CK

DAM		Calv.Ease	BW	WW	YW	Milk	HPG	Stay	Maint.En.
Age	2	13	-2.8	27	63	12	9	11	+0.3
Wt	890								
Prog.BW	61								
WR	102								
YR	113								
Wean Pct.	55%								
Cow Eff.	115								
		Marb	+0.08		REA	+0.22		Bfat	+0.01
BWt	WWt	WR	ADG	YWt	YR	Scr.	Fr.		
61	548	102	4.95	1146	113	35	5.5		

★★★★★ for Low Maintenance, Growth, Gainability, Rib-eye area, Calving Ease.

42 **BSF NEBULA U292 N**
1-B 99% # 1259240 Tattoo: BSF8 U292

Birth: 3-16-08
 Beckton Nebula M045
BECKTON NEBULA N R573
 Ref. N-5
 Beckton Lana M621 LN
 Beckton Neptune R2 K065
 Beckton Belga K285 JL
 Beckton Lancer F442 T
 Beckton Lana H329 HD
 Beckton Herald F FA20
 Beckton Kuruba F588 VG
 Beckton Julian G1 J526
 BSF Regus J077
 Beckton Herald FV J537
BSF HERA P142
 BSF Regus L054 JL

DAM		Calv.Ease	BW	WW	YW	Milk	HPG	Stay	Maint.En.
Age	4	11	-1.5	34	70	14	10	13	+3.1
Wt	1115								
Prog.BW	71								
WR	109								
YR	108								
Wean Pct.	52%								
Cow Eff.	109								
		Marb	+0.08		REA	+0.06		Bfat	-0.01
BWt	WWt	WR	ADG	YWt	YR	Scr.	Fr.		
77	598	103	4.85	1213	111	37	5.5		

★★★★★ for Low Maintenance, Growth, Gainability, Superior Cow, Calving Ease, Stayability.

40 **BSF EPIC U299 KM**
1-B 99% # 1259220 Tattoo: BSF8 U299

Birth: 3-16-08
 Beckton Epic K F075
BECKTON EPIC KM M115
 Ref. E-1
 Beckton Minerva F495 CH
 Beckton Epic D404
 Beckton Belga D483 KR
 Beckton Champ R A583
 Beckton Minerva CB69 JL
 Beckton Hustler C G407
 Beckton Belga G355 NP
 Beckton Vegas P D462
 Bkt Regus D034
 Beckton Hustler CN J102
BSF HELENA N151 HU
 BSF Regus F175

DAM		Calv.Ease	BW	WW	YW	Milk	HPG	Stay	Maint.En.
Age	5	8	-0.4	43	85	20	7	9	+3.1
Wt	1105								
Prog.BW	68								
WR	104								
YR	105								
Wean Pct.	58%								
Cow Eff.	123								
		Marb	+0.14		REA	+0.00		Bfat	-0.01
BWt	WWt	WR	ADG	YWt	YR	Scr.	Fr.		
83	645	105	4.85	1221	110	43	6.0		

★★★★★ for Low Maintenance, Growth, Gainability, Marbling, Superior Cow, High Cow Efficiency, Calving Ease.

43 **BSF EPIC U191 K4**
1-B 99% # 1259214 Tattoo: BSF8 U191

Birth: 3-12-08
 Beckton Epic KJ J722
BECKTON EPIC K4 N795
 Ref. E-2
 Beckton Sierra J789 EP
 Beckton Epic K F075
 Beckton Epic K F075
 Beckton Lana F891 JL
 Beckton Epic D404
 Beckton Sierra C157 CL
 Beckton Epic D404
 Beckton Belga D483 KR
 Beckton Vegas S F382
 BSF Regus F215
BSF REGUS M717 EP
 BSF Regus H098

DAM		Calv.Ease	BW	WW	YW	Milk	HPG	Stay	Maint.En.
Age	6	8	-1.0	35	73	14	9	10	-2.8
Wt	1060								
Prog.BW	68								
WR	104								
YR	104								
Wean Pct.	58%								
Cow Eff.	122								
		Marb	+0.12		REA	+0.07		Bfat	+0.01
BWt	WWt	WR	ADG	YWt	YR	Scr.	Fr.		
81	613	105	4.90	1153	106	37	5.5		

★★★★★ for Low Maintenance, Growth, Gainability, Marbling, Superior Cow, High Cow Efficiency, Calving Ease.

41 **BSF JULIAN U486 G3**
1-B 99% # 1259251 Tattoo: BSF8 U486

Birth: 3-23-08
 Beckton Julian GG B571
BECKTON JULIAN G3 P608
 Ref. J-6
 Bkt Suffeina A828 DM
 Beckton Lancer T4 J536
BSF LANETTE P615
 BSF Regus F697
 Beckton Julian 7526G
 Bkt Marta 9A13 JL
 Beckton Dominor 9455
 Bkt Suffeina 9493 TT
 Beckton Lancer TZ D525
 Beckton Vernice D121 VG
 Beckton Hadrian F C486
 BSF Regus C550

DAM		Calv.Ease	BW	WW	YW	Milk	HPG	Stay	Maint.En.
Age	4	15	-3.3	26	59	15	11	15	+2.1
Wt	1270								
Prog.BW	64								
WR	109								
YR	107								
Wean Pct.	49%								
Cow Eff.	102								
		Marb	+0.04		REA	+0.07		Bfat	-0.01
BWt	WWt	WR	ADG	YWt	YR	Scr.	Fr.		
72	638	109	3.98	1214	111	37	5.5		

★★★★★ for Low Maintenance, Superior Cow, Calving Ease, Stayability.



• Bulls •

44 BSF NEBULA U307 L

1-B 99% # 1259224 Tattoo: BSF8 U307

Birth: 3-16-08
 Beckton Nebula M045
BECKTON NEBULA L P093
 Ref. N-3
 Beckton Marta M021 LN
 Beckton Neptune R2 K065
 Beckton Belga K285 JL
 Beckton Lancer TA K644
 Beckton Marta K254 LN
 Beckton Lancer T4 J536
 Beckton Sierra J659 DM
 Beckton Herald FV J537
 BSF Regus J870

DAM		Calv.Ease	BW	WW	YW	Milk	HPG	Stay	Maint.En.
Age	5	13	-2.5	30	63	10	9	13	-2.1
Wt	1180	Marb +1.0		REA -.01		Bfat -.01			
Prog.BW	71	BWt	WWt	WR	ADG	YWt	YR	Scr.	Fr.
WR	101	72	518	88	4.90	1117	98	36	6.0
YR	104								
Wean Pct.	44%								
Cow Eff.	92								

★★★★★ for Low Maintenance, Gainability, Calving Ease, Stayability.

47 BECKTON EPIC U098 K6

1-A 100% # 1259078 Tattoo: WF8 U098

Birth: 3-2-08
 Beckton Epic KM M115
BECKTON EPIC K6 S569
 Ref. E-5
 Beckton Sierra N703 LM
 Beckton Epic K F075
 Beckton Minerva F495 CH
 Beckton Laramie L044
 Beckton Sierra L887 LN
 Beckton Nebula M045
 Beckton Lana M809 EP
 Beckton Champ R3 H338
 Beckton Lana F483 ZN

DAM		Calv.Ease	BW	WW	YW	Milk	HPG	Stay	Maint.En.
Age	2	12	-2.8	37	78	17	6	12	+1.7
Wt	815	Marb +0.05		REA +1.14		Bfat +0.01			
Prog.BW	65	BWt	WWt	WR	ADG	YWt	YR	Scr.	Fr.
WR	109	65	584	109	4.24	1130	111	34	5.5
YR	111								
Wean Pct.	64%								
Cow Eff.	135								

★★★★★ for Low Maintenance, Growth, Gainability, Rib-eye area, Superior Cow, High Cow Efficiency, Calving Ease.

45 BECKTON NEBULA U192 L

1-A 100% # 1258871 Tattoo: WF8 U192

Birth: 3-12-08
 Beckton Nebula M045
BECKTON NEBULA L P093
 Ref. N-3
 Beckton Marta M021 LN
 Beckton Epic D404
BECKTON LANA K237 EP
 Beckton Lana CB29 JL
 Beckton Neptune R2 K065
 Beckton Belga K285 JL
 Beckton Lancer TA K644
 Beckton Marta K254 LN
 Beckton Saga KJ B702
 Beckton Kuruba B508 PC
 Beckton Julian 8970S
 Beckton Lana 7600 PN

DAM		Calv.Ease	BW	WW	YW	Milk	HPG	Stay	Maint.En.
Age	8	15	-4.9	26	60	8	9	13	-6.1
Wt	1115	Marb +0.04		REA +1.19		Bfat +0.00			
Prog.BW	64	BWt	WWt	WR	ADG	YWt	YR	Scr.	Fr.
WR	99	64	632	108	4.13	1168	107	39	5.0
YR	100								
Wean Pct.	57%								
Cow Eff.	119								

★★★★★ for Low Maintenance, Gainability, Rib-eye area, High Cow Efficiency, Calving Ease, Stayability.

48 BECKTON CHEROKEE U517 N

1-A 100% # 1259378 Tattoo: BKT8 U517

Birth: 3-24-08
 BFCK Cherokee Cynr 4912
BECKTON CHEROKEE N N479
 Ref. B-1
 Beckton Dinah C440 NM
 Beckton Lancer TS D390
BKT LARKEISA H478 LN
 Bkt Larkeisa C159 CL
 BUF CRK Chief 824-1658
 MRM 1431 8611 9109
 Beckton Nomad K 9949
 Beckton Dinah Z610 JL
 Beckton Lancer T A664
 Beckton Coca 7536 SB
 Beckton Clipper K Z420
 Bkt Larkeisa 7032 TJ

DAM		Calv.Ease	BW	WW	YW	Milk	HPG	Stay	Maint.En.
Age	10	12	-3.1	30	52	15	9	11	-1.3
Wt	1120	Marb +1.10		REA +0.04		Bfat +0.01			
Prog.BW	74	BWt	WWt	WR	ADG	YWt	YR	Scr.	Fr.
WR	100	79	636	104	4.44	1167	105	39	5.0
YR	99								
Wean Pct.	57%								
Cow Eff.	120								

★★★★★ for Low Maintenance, Gainability, High Cow Efficiency, Calving Ease.

46 BECKTON JORDAN U520

1-A 100% # 1258996 Tattoo: WF8 U520

Birth: 3-24-08
 TR Julian LT151
TR JULIAN RT561
 Ref. J-13
 TR Dyna HT824
 Beckton Julian GG B571
BECKTON SUFFEINA P643 JL
 Bkt Suffeina A828 DM
 Beckton Julian GG B571
 MS Geometric 917
 Buf Crk Dynamics 3820
 Buf Crk Dyna 3082
 Beckton Julian 7526G
 Bkt Marta 9A13 JL
 Beckton Dominor 9455
 Bkt Suffeina 9493 TT

DAM		Calv.Ease	BW	WW	YW	Milk	HPG	Stay	Maint.En.
Age	4	14	-2.1	29	57	13	11	16	-1.1
Wt	960	Marb +1.12		REA +2.26		Bfat +0.00			
Prog.BW	74	BWt	WWt	WR	ADG	YWt	YR	Scr.	Fr.
WR	107	76	639	104	4.34	1159	105	37	5.5
YR	107								
Wean Pct.	65%								
Cow Eff.	136								

★★★★★ for Low Maintenance, Gainability, Marbling, Rib-eye area, Superior Cow, High Cow Efficiency, Calving Ease, Stayability.

49 BECKTON NEBULA U149 P

1-A 100% # 1259488 Tattoo: BKT8 U149

Birth: 3-8-08
 Beckton Nebula M045
BECKTON NEBULA P P707
 Ref. N-4
 Beckton Lana M809 EP
 Beckton Julio L233
BECKTON TAMARA P243 JO
 Beckton Tamara K767 HR
 Beckton Neptune R2 K065
 Beckton Belga K285 JL
 Beckton Epic K1 K863
 Beckton Lana K253 DM
 Beckton Julian G1 J526
 Beckton Rose J725 EP
 Beckton Herald F FA20
 Beckton Tamara G058 CO

DAM		Calv.Ease	BW	WW	YW	Milk	HPG	Stay	Maint.En.
Age	4	13	-2.5	38	65	15	10	13	-2.5
Wt	1180	Marb +1.12		REA +1.11		Bfat +0.01			
Prog.BW	73	BWt	WWt	WR	ADG	YWt	YR	Scr.	Fr.
WR	103	75	665	114	3.57	1117	102	34	5.5
YR	99								
Wean Pct.	55%								
Cow Eff.	115								

★★★★★ for Low Maintenance, Marbling, Calving Ease, Stayability.

• Bulls •

50 BECKTON JULIAN U260 G3

1-A 100% # 1258946 Tattoo: WF8 U260

Birth: 3-14-08

Beckton Julian GG B571
BECKTON JULIAN G3 P608
 Ref. J-6 Bkt Suffeina A828 DM

Beckton Julian 7526G
 Bkt Marta 9A13 JL

Beckton Dominor 9455
 Bkt Suffeina 9493 TT

Beckton Copper J E616
 Beckton Ruth E549 TP

BECKTON ROSE N607 CO
 Beckton Copper JT G095
 Beckton Rose J725 EP
 Beckton Epic K F075
 Beckton Rose F192 CL

DAM		Calv.Ease	BW	WW	YW	Milk	HPG	Stay	Maint.En.
Age	5	15	-6.1	16	45	15	11	15	-3.4
Wt	1115	Marb +0.19		REA +0.00		Bfat +0.02			
Prog.BW	68	BWt	WWt	WR	ADG	YWt	YR	Scr.	Fr.
WR	94	65	568	97	4.29	1099	101	34	5.5
YR	99								
Wean Pct.	51%								
Cow Eff.	107								

★★★★★ for Low Maintenance, Gainability, Marbling, Calving Ease, Stayability.

52 BECKTON HASTEN U006 H

1-A 100% # 1259101 Tattoo: WF8 U006

Birth: 2-12-08

Beckton Hasten P292
BECKTON HASTEN H S462
 Ref. H-3 Beckton Lakme G128 HD

Beckton Hustler C2 L079
 Beckton Sheba L644 CH

Beckton Hadrian FC E166
 Beckton Lakme E373 CL

Beckton Epic KJ J722
 Beckton Lana F268 CT

BECKTON FREYJA S297 EP
 Beckton Epic K3 M606
 Beckton Freyja M659 WR
 Beckton Warrior T C371
 Beckton Freyja B572 JL

DAM		Calv.Ease	BW	WW	YW	Milk	HPG	Stay	Maint.En.
Age	2	9	-1.3	30	58	17	10	10	-2.7
Wt	800	Marb +0.04		REA +0.16		Bfat -0.01			
Prog.BW	72	BWt	WWt	WR	ADG	YWt	YR	Scr.	Fr.
WR	104	72	592	104	3.93	1081	104	34	5.5
YR	104								
Wean Pct.	67%								
Cow Eff.	140								

★★★★★ for Low Maintenance, Rib-eye area, Superior Cow, High Cow Efficiency, Calving Ease.



53 BECKTON EPIC U363 K4

1-A 100% # 1259547 Tattoo: BKT8 U363

Birth: 3-18-08

Beckton Epic KJ J722
BECKTON EPIC K4 N795
 Ref. E-2 Beckton Sierra J789 EP

Beckton Epic K F075
 Beckton Lana F891 JL

Beckton Epic D404
 Beckton Sierra C157 CL

Beckton Justice CH M056
 Beckton Ruth K802 HD

BECKTON ENCINO R207 JC
 Beckton Justice C K449
 Beckton Brutus T E062
 Beckton Encino E821 JL

DAM		Calv.Ease	BW	WW	YW	Milk	HPG	Stay	Maint.En.
Age	3	11	-1.8	34	71	13	9	10	+2.8
Wt	960	Marb +0.22		REA +0.17		Bfat +0.00			
Prog.BW	65	BWt	WWt	WR	ADG	YWt	YR	Scr.	Fr.
WR	112	68	633	111	3.88	1152	107	34	5.5
YR	110								
Wean Pct.	62%								
Cow Eff.	130								

★★★★★ for Low Maintenance, Growth, Marbling, Rib-eye area, Superior Cow, High Cow Efficiency, Calving Ease.

51 BECKTON LANCER U291 TD

1-A 100% # 1259393 Tattoo: BKT8 U291

Birth: 3-16-08

Beckton Lancer T A664
BECKTON LANCER F442 T
 Ref. L-1 Bkt Suffeina A828 DM

Beckton Lancer 9380
 Beckton Coca 9119 TJ

Beckton Dominor 9455
 Bkt Suffeina 9493 TT

Beckton Lancer T A664
 Beckton Coca 7536 SB

BECKTON BELGA K117 LN
 Beckton Lancer TS D390
 Beckton Belga G458 CT
 Beckton Cliffot T C075
 Beckton Belga C646 JV

DAM		Calv.Ease	BW	WW	YW	Milk	HPG	Stay	Maint.En.
Age	8	10	-1.5	32	51	9	5	13	-3.9
Wt	1135	Marb +0.17		REA +0.22		Bfat -0.02			
Prog.BW	71	BWt	WWt	WR	ADG	YWt	YR	Scr.	Fr.
WR	102	79	613	105	3.98	1113	102	37	5.5
YR	99								
Wean Pct.	54%								
Cow Eff.	114								

★★★★★ for Low Maintenance, Marbling, Rib-eye area, Calving Ease, Stayability.

54 BECKTON EPIC U323 KD

1-A 100% # 1258877 Tattoo: WF8 U323

Birth: 3-17-08

Beckton Epic K F075
BECKTON EPIC R350 K
 Ref. E-3 Beckton Larkaba E042 CD

Beckton Epic D404
 Beckton Belga D483 KR

Beckton Cody C401
 Beckton Larkaba C317 CL

Beckton Copper J E616
 Beckton Ruth E549 TP

BECKTON MINOLA K527 CO
 Beckton Copper JT G095
 Beckton Minola F003 CR
 Beckton Colter D392
 Beckton Minola D203 KR

DAM		Calv.Ease	BW	WW	YW	Milk	HPG	Stay	Maint.En.
Age	8	10	-3.0	26	53	16	10	10	-2.2
Wt	1040	Marb +0.10		REA -0.13		Bfat +0.01			
Prog.BW	74	BWt	WWt	WR	ADG	YWt	YR	Scr.	Fr.
WR	100	73	582	100	3.98	1097	100	37	5.5
YR	100								
Wean Pct.	56%								
Cow Eff.	118								

★★★★★ for Low Maintenance, High Cow Efficiency, Calving Ease.

• Bulls •



55 BECKTON CLIFFTOP U474 T
1-A 100% # 1258926 Tattoo: WF8 U474

Birth: 3-22-08
 ✓ BJR Topper 5241
 ✓ Bieber Topper 2476
 ✓ BJR Lakina 002-0142
BECKTON CLIFFTOP T C075
 Ref. ✓ Beckton Barmaid A761 TR
 ✓ Beckton Tartan 8148
 ✓ Bkt Barmaid 8925 KR
 ✓ Beckton Hustler C2 L079
 ✓ Beckton Hustler CN J102
 ✓ Beckton Barmaid J012 CO
BECKTON RUTH N119 HU
 ✓ Beckton Ruth LA092 JL
 ✓ Beckton Julian 7526G
 ✓ Beckton Ruth B634 MB

DAM		Calv.Ease	BW	WW	YW	Milk	HPG	Stay	Maint.En.
Age	5	11	-3.7	25	47	13	10	14	-2.3
Wt	1035								
Prog.BW	75								
WR	104								
YR	97								
Wean Pct.	57%								
Cow Eff.	120								
		Marb			REA				Bfat
		+10			+02				-.02
		BWt	WWt	WR	ADG	YWt	YR	Scr.	Fr.
		74	590	101	3.72	1101	101	34	5.5

★★★★★ for Low Maintenance, High Cow Efficiency, Calving Ease, Stayability.

56 BECKTON EPIC U747 KM
1-A 100% # 1258860 Tattoo: WF8 U747

Birth: 4-9-08
 ✓ Beckton Epic K F075
 ✓ Beckton Epic D404
 ✓ Beckton Belga D483 KR
BECKTON EPIC KM M115
 Ref. E-1 ✓ Beckton Minerva F495 CH
 ✓ Beckton Champ R A583
 ✓ Beckton Minerva CB69 JL
 ✓ Beckton Lancer TS D390
 ✓ Beckton Lancer T A664
 ✓ Beckton Coca 7536 SB
BECKTON MINOLA J409 LN
 ✓ Beckton Minola D494 SC
 ✓ Beckton Scamp KS B372
 ✓ Beckton Minola B274 BN

DAM		Calv.Ease	BW	WW	YW	Milk	HPG	Stay	Maint.En.
Age	9	10	-0.5	34	64	16	5	11	+0.7
Wt	1020								
Prog.BW	74								
WR	102								
YR	103								
Wean Pct.	63%								
Cow Eff.	132								
		Marb			REA				Bfat
		+08			-.07				+01
		BWt	WWt	WR	ADG	YWt	YR	Scr.	Fr.
		80	641	104	4.34	1158	104	37	5.5

★★★★★ for Low Maintenance, Gainability, High Cow Efficiency, Calving Ease.

58 BSF EPIC U412 KM
1-B 99% # 1259260 Tattoo: BSF8 U412

Birth: 3-20-08
 ✓ Beckton Epic K F075
 ✓ Beckton Epic D404
 ✓ Beckton Belga D483 KR
BECKTON EPIC KM M115
 Ref. E-1 ✓ Beckton Minerva F495 CH
 ✓ Beckton Champ R A583
 ✓ Beckton Minerva CB69 JL
 ✓ Beckton Warrior T1 H281
 ✓ Beckton Firefly H195 HD
BSF HELENA R003 WA
 ✓ BSF Helena N151 HU
 ✓ Beckton Hustler CN J102
 ✓ BSF Regus F175

DAM		Calv.Ease	BW	WW	YW	Milk	HPG	Stay	Maint.En.
Age	3	10	-2.4	39	83	21	8	10	+3.9
Wt	1055								
Prog.BW	71								
WR	115								
YR	113								
Wean Pct.	59%								
Cow Eff.	124								
		Marb			REA				Bfat
		+15			+02				+00
		BWt	WWt	WR	ADG	YWt	YR	Scr.	Fr.
		74	661	114	5.10	1229	115	35	5.5

★★★★★ for Low Maintenance, Growth, Gainability, Marbling, Superior Cow, High Cow Efficiency, Calving Ease.

57 BKB JUSTICE U243 CH
1-B 98% # 1259159 Tattoo: BKB8 U243

Birth: 3-14-08
 ✓ Beckton Justice C K449
 ✓ Beckton Justice G302
 ✓ Bkt Larkabel C742 CF
BECKTON JUSTICE CH M056
 Ref. J-3 ✓ Beckton Ruth K802 HD
 ✓ Beckton Hadrian F C486
 ✓ Beckton Ruth G534 NP
 ✓ Beckton Emperor C369
 ✓ Beckton Kaiser FD 9253
 ✓ Bkt Suffeina Z303 RD
BSF REGUS G195
 ✓ BSF Regus 8099
 ✓ BSF Xima 1176 F
 ✓ BSF Red 4125

DAM		Calv.Ease	BW	WW	YW	Milk	HPG	Stay	Maint.En.
Age	11	11	-1.9	32	57	13	11	10	-4.7
Wt	1110								
Prog.BW	73								
WR	106								
YR	103								
Wean Pct.	58%								
Cow Eff.	122								
		Marb			REA				Bfat
		+15			+15				-.01
		BWt	WWt	WR	ADG	YWt	YR	Scr.	Fr.
		74	663	112	4.13	1197	106	37	5.5

★★★★★ for Low Maintenance, Gainability, Marbling, Rib-eye area, Superior Cow, High Cow Efficiency, Calving Ease.

59 BSF CODY U694 K2
1-B 94% # 1259168 Tattoo: BSF8 U694

Birth: 4-4-08
 ✓ Beckton Cody KH M390
 ✓ Beckton Cody K G701
 ✓ Beckton Tamara J124 HR
BECKTON CODY K2 R168
 Ref. C-2 ✓ Beckton Tamara K249 VG
 ✓ Beckton Vegas SV H078
 ✓ Beckton Tamara HA38 WR
 ✓ Beckton Julian 7526G
 ✓ Beckton Julian 6592
 ✓ Bkt Belga 6746 GS
BSF REGUS F712
 ✓ BSF Red 5289-2
 ✓ BSF Red 8127
 ✓ BSF Red 8314

DAM		Calv.Ease	BW	WW	YW	Milk	HPG	Stay	Maint.En.
Age	12	10	-1.3	35	66	16	12	12	-0.9
Wt	1190								
Prog.BW	78								
WR	107								
YR	101								
Wean Pct.	53%								
Cow Eff.	111								
		Marb			REA				Bfat
		-.04			+14				+01
		BWt	WWt	WR	ADG	YWt	YR	Scr.	Fr.
		77	649	110	4.69	1226	108	35	5.5

★★★★★ for Low Maintenance, Growth, Gainability, Rib-eye area, Calving Ease.

• Bulls •

60 **BSF CLIFFTOP U767 T3**
1-B 99% # 1259199 Tattoo: BSF8 U767

Birth: 4-12-08
 ↙ Bkt Clifftop TV G672
BECKTON CLIFFTOP T3 N800
 Ref. B-2 ↘ Beckton Lana J384 CD
 ↙ Beckton Justice C K449
BSF REGUS M057 JC
 ↘ BSF Regus K184 HD
 ↙ Beckton Birdie C353 VG
 ↘ Beckton Cody K G701
 ↙ Beckton Lana G514 CD
 ↘ Beckton Justice G302
 ↙ Bkt Larkabel C742 CF
 ↘ Beckton Hadrian F C486
 ↙ BSF Regus G340

DAM		Calv.Ease	BW	WW	YW	Milk	HPG	Stay	Maint.En.
Age	6	10	+1.9	40	77	13	11	9	+1.7
Wt	1030	Marb +.24		REA +.07		Bfat -.01			
Prog.BW	64	BWt	WWt	WR	ADG	YWt	YR	Scr.	Fr.
WR	99	85	671	115	4.49	1254	115	36	5.5
YR	111								
Wean Pct.	65%								
Cow Eff.	137								

★★★★★ for Low Maintenance, Growth, Gainability, Marbling, High Cow Efficiency, Calving Ease.

63 **BSF CHEROKEE U180 N**
1-B 99% # 1259191 Tattoo: BSF8 U180

Birth: 3-11-08
 ↙ BFCK Cherokee Cnyn 4912
BECKTON CHEROKEE N N479
 Ref. B-1 ↘ Beckton Dinah C440 NM
 ↙ Beckton Warrior T C371
BSF REGUS L465 WR
 ↘ WF Regus H107
 ↙ BUF CRK Chief 824-1658
 ↘ MRM 1431 8611 9109
 ↙ Beckton Nomad K 9949
 ↘ Beckton Dinah Z610 JL
 ↙ JKG Chiefton L303
 ↘ Beckton Tamla A671 TR
 ↙ BSF Casper F784
 ↘ Bkt Sunflower F257 CS

DAM		Calv.Ease	BW	WW	YW	Milk	HPG	Stay	Maint.En.
Age	7	10	-2.8	34	56	18	11	9	-0.6
Wt	1260	Marb +.07		REA +.06		Bfat +.01			
Prog.BW	81	BWt	WWt	WR	ADG	YWt	YR	Scr.	Fr.
WR	99	80	623	106	3.93	1136	100	41	5.0
YR	106								
Wean Pct.	49%								
Cow Eff.	104								

★★★★★ for Low Maintenance, Calving Ease.

61 **BSF NEBULA U400 E**
1-B 99% # 1259222 Tattoo: BSF8 U400

Birth: 3-20-08
 ↙ Beckton Nebula M045
BECKTON NEBULA E P084
 Ref. N-2 ↘ BKT Pine Marie M119 EP
 ↙ Beckton Epic KJ J722
BSF ERICA N159 EP
 ↘ BSF Red G006
 ↙ Beckton Neptune R2 K065
 ↘ Beckton Belga K285 JL
 ↙ Beckton Epic K F075
 ↘ Bkt Pine Marie D126 JL
 ↙ Beckton Epic K F075
 ↘ Beckton Lana F891 JL
 ↙ Beckton Julius E349
 ↘ BSF Regus E305

DAM		Calv.Ease	BW	WW	YW	Milk	HPG	Stay	Maint.En.
Age	5	14	-4.0	24	55	14	11	16	-4.7
Wt	1165	Marb +.23		REA +.02		Bfat +.01			
Prog.BW	74	BWt	WWt	WR	ADG	YWt	YR	Scr.	Fr.
WR	107	73	615	106	4.59	1155	106	39	5.5
YR	113								
Wean Pct.	53%								
Cow Eff.	111								

★★★★★ for Low Maintenance, Gainability, Marbling, Superior Cow, Calving Ease, Stayability.

64 **BSF EPIC U345 K4**
1-B 99% # 1259268 Tattoo: BSF8 U345

Birth: 3-18-08
 ↙ Beckton Epic KJ J722
BECKTON EPIC K4 N795
 Ref. E-2 ↘ Beckton Sierra J789 EP
 ↙ Beckton Lancer T8 N377
BSF COQUETTE R240 LN
 ↘ BSF Coquette N706 CE
 ↙ Beckton Epic K F075
 ↘ Beckton Lana F891 JL
 ↙ Beckton Epic D404
 ↘ Beckton Sierra C157 CL
 ↙ Beckton Lancer F270 T
 ↘ Beckton Minerva H633 LN
 ↙ Beckton Cruiser K118
 ↘ BSF Regus D322

DAM		Calv.Ease	BW	WW	YW	Milk	HPG	Stay	Maint.En.
Age	3	8	+0.5	37	75	10	9	9	-0.8
Wt	935	Marb +.10		REA +.09		Bfat +.01			
Prog.BW	73	BWt	WWt	WR	ADG	YWt	YR	Scr.	Fr.
WR	101	77	622	109	4.54	1159	107	36	6.0
YR	104								
Wean Pct.	62%								
Cow Eff.	131								

★★★★★ for Low Maintenance, Growth, Gainability, High Cow Efficiency, Calving Ease.

62 **BSF NEBULA U049 PJ**
1-B 99% # 1259306 Tattoo: BSF8 U049

Birth: 2-23-08
 ↙ Beckton Nebula P P707
BECKTON NEBULA PJ S543
 Ref. N-8 ↘ Beckton Lana P685 JO
 ↙ Beckton Vega P079
BSF NEPTALA S036 VA
 ↘ BSF Neptala P301
 ↙ Beckton Nebula M045
 ↘ Beckton Lana M809 EP
 ↙ Beckton Julio L233
 ↘ Beckton Lana E083 CD
 ↙ Beckton Vegas S1 K316
 ↘ Beckton Lydia H159 JL
 ↙ Beckton Neptune R2 K065
 ↘ BSF Regus L616 LN

DAM		Calv.Ease	BW	WW	YW	Milk	HPG	Stay	Maint.En.
Age	2	13	-2.2	41	75	16	9	14	+3.7
Wt	900	Marb +.10		REA +.28		Bfat +.01			
Prog.BW	65	BWt	WWt	WR	ADG	YWt	YR	Scr.	Fr.
WR	118	65	633	118	4.13	1130	111	33	5.5
YR	111								
Wean Pct.	64%								
Cow Eff.	134								

★★★★★ for Low Maintenance, Growth, Gainability, Rib-eye area, Superior Cow, High Cow Efficiency, Calving Ease, Stayability.



• Bulls •



65 **BSF JUSTICE U141 CH**
1-B 99% # 1259203 Tattoo: BSF8 U141

Birth: 3-7-08

Beckton Justice C K449
Beckton Justice G302
Bkt Larkabel C742 CF

BECKTON JUSTICE CH M056
Ref. J-3
Beckton Ruth K802 HD
Beckton Hadrian F C486
Beckton Ruth G534 NP

Beckton Lancer T1 H080
Beckton Lancer TN F726
Beckton Belga F657 TP

BSF REGUS M209 LN
Beckton Hadrian A100
BSF Regus A338
BSF Regus D305

DAM		Calv.Ease	BW	WW	YW	Milk	HPG	Stay	Maint.En.
Age	6	12	-0.5	32	63	6	11	10	-0.3
Wt	1195								
Prog.BW	65								
WR	94								
YR	100								
Wean Pct.	48%								
Cow Eff.	101								

Marb **+0.22** REA **+0.00** Bfat **-0.01**

BWt	WWt	WR	ADG	YWt	YR	Scr.	Fr.
77	571	98	3.98	1110	102	36	5.5

★★★★★ for Low Maintenance, Marbling, Calving Ease.

66 **BSF VEGA U847**
1-B 99% # 1259290 Tattoo: BSF8 U847

Birth: 4-26-08

Beckton Vegas S1 K316
Beckton Vegas SV H078
Beckton Eola H073 EP

BECKTON VEGA P079
Ref. V-1
Beckton Lydia H159 JL
Beckton Julian GG B571
Beckton Lydia D386 CL

Beckton Julian G1 J526
Beckton Julian GG B571
Beckton Annie F743 LN

BSF JULIANNE R723 JL
Beckton Warrior T2 J333
BSF Regus J306
BSF Red L060 WR

DAM		Calv.Ease	BW	WW	YW	Milk	HPG	Stay	Maint.En.
Age	3	11	+0.8	43	77	13	9	13	+7.5
Wt	1145								
Prog.BW	68								
WR	106								
YR	103								
Wean Pct.	56%								
Cow Eff.	117								

Marb **+0.06** REA **+0.15** Bfat **+0.00**

BWt	WWt	WR	ADG	YWt	YR	Scr.	Fr.
80	676	119	4.64	1228	114	36	6.0

★★★★★ for Growth, Gainability, Rib-eye area, Superior Cow, High Cow Efficiency, Calving Ease, Stayability.

68 **BSF CODY U661 K1**
1-B 99% # 1259205 Tattoo: BSF8 U661

Birth: 4-1-08

Beckton Cody KH M390
Beckton Cody K G701
Beckton Tamara J124 HR

BECKTON CODY K1 P014
Ref. C-1
Beckton Rose M126 WR
Beckton Warrior T C371
Beckton Rose D741 LN

Beckton Epic K F075
Beckton Epic D404
Beckton Belga D483 KR

BSF REGUS M394 EP
Beckton Nomad V 9871
BSF Regus G483
BSF Regus D019

DAM		Calv.Ease	BW	WW	YW	Milk	HPG	Stay	Maint.En.
Age	6	9	-1.1	33	64	17	8	9	+2.9
Wt	1265								
Prog.BW	73								
WR	106								
YR	100								
Wean Pct.	50%								
Cow Eff.	106								

Marb **-0.01** REA **+0.15** Bfat **+0.01**

BWt	WWt	WR	ADG	YWt	YR	Scr.	Fr.
85	637	109	4.13	1149	105	36	5.5

★★★★★ for Low Maintenance, Growth, Gainability, Rib-eye area, Calving Ease.

67 **BSF LANCER U617 T9**
1-B 99% # 1259259 Tattoo: BSF8 U617

Birth: 3-28-08

Beckton Lancer TA K644
Beckton Lancer T A664
Beckton Tamara B570 JL

BECKTON LANCER T9 N586
Ref. L-2
BKT Larkeisa H232 SC
Beckton Scamp TR FB22
Bkt Larkeisa F828 JL

Beckton Warhawk N560
Beckton Warrior T1 H281
Beckton Firefly H195 HD

BSF HELENA R002 WA
BSF Helena N252 HR
Beckton Herald F1 L151
BSF Regus L359 CO

DAM		Calv.Ease	BW	WW	YW	Milk	HPG	Stay	Maint.En.
Age	3	12	-1.9	31	61	15	12	10	+0.8
Wt	1060								
Prog.BW	75								
WR	114								
YR	110								
Wean Pct.	58%								
Cow Eff.	121								

Marb **+0.10** REA **+0.02** Bfat **-0.01**

BWt	WWt	WR	ADG	YWt	YR	Scr.	Fr.
75	651	114	4.34	1190	110	38	5.5

★★★★★ for Low Maintenance, Growth, Gainability, Superior Cow, High Cow Efficiency, Calving Ease.

69 **BECKTON NEBULA U127 G**
1-A 100% # 1259091 Tattoo: WF8 U127

Birth: 3-5-08

Beckton Nebula M045
Beckton Neptune R2 K065
Beckton Belga K285 JL

BECKTON NEBULA G S237
Ref. N-6
Beckton Lakme LA06 JL
Beckton Julian GG B571
Beckton Lakme B370 HV

Beckton Lariat P229
Beckton Lancer T1 H080
Beckton Vernice L382 LN

BECKTON LARKABA S200 LA
Beckton Herald FV J537
Beckton Larkaba D170 JV
Beckton Larkaba P377 HR

DAM		Calv.Ease	BW	WW	YW	Milk	HPG	Stay	Maint.En.
Age	2	14	-2.3	28	63	11	8	13	-3.0
Wt	800								
Prog.BW	66								
WR	106								
YR	114								
Wean Pct.	63%								
Cow Eff.	134								

Marb **+0.17** REA **+0.09** Bfat **+0.01**

BWt	WWt	WR	ADG	YWt	YR	Scr.	Fr.
66	567	106	4.59	1155	114	36	5.0

★★★★★ for Low Maintenance, Growth, Gainability, Marbling, Superior Cow, High Cow Efficiency, Calving Ease, Stayability.

• Bulls •

70 **BECKTON EPIC U805 K4**
1-A 100% # 1258917 Tattoo: WF8 U805

Birth: 4-17-08

Beckton Epic KJ J722
BECKTON EPIC K4 N795
 Ref. E-2
 Beckton Sierra J789 EP
 Beckton Epic K F075
 Beckton Lana F891 JL
 Beckton Epic D404
 Beckton Sierra C157 CL
 Beckton Epic KN H110
 Beckton Rose H019 SC
 Beckton Epic KN H110
 Beckton Eola H481 HD
BECKTON EOLA M663 EP
 Beckton Epic K1 K863
 Beckton Eola K178 EP

DAM		Calv.Ease	BW	WW	YW	Milk	HPG	Stay	Maint.En.
Age	6	8	.0	36	76	15	9	10	-2.9
Wt	1020	Marb +0.21		REA +0.05		Bfat +0.02			
Prog.BW	70	BWt	WWt	WR	ADG	YWt	YR	Scr.	Fr.
WR	103	83	660	113	4.64	1230	113	36	6.0
YR	103								
Wean Pct.	65%								
Cow Eff.	136								

★★★★★ for Low Maintenance, Growth, Gainability, Marbling, Superior Cow, High Cow Efficiency, Calving Ease.

72 **BECKTON EPIC U649 K4**
1-A 100% # 1258975 Tattoo: WF8 U649

Birth: 3-31-08

Beckton Epic KJ J722
BECKTON EPIC K4 N795
 Ref. E-2
 Beckton Sierra J789 EP
 Beckton Epic K F075
 Beckton Lana F891 JL
 Beckton Epic D404
 Beckton Sierra C157 CL
 Beckton Julian G1 J526
 Beckton Rose J725 EP
 Beckton Copper J E616
 Beckton Rose F280 JL
BECKTON ROSE P376 JO
 Beckton Julio L233
 Beckton Rose J565 CO

DAM		Calv.Ease	BW	WW	YW	Milk	HPG	Stay	Maint.En.
Age	4	8	-0.5	28	71	13	8	13	-0.7
Wt	1125	Marb +0.18		REA +0.11		Bfat +0.01			
Prog.BW	77	BWt	WWt	WR	ADG	YWt	YR	Scr.	Fr.
WR	102	83	580	94	5.05	1172	106	35	5.5
YR	110								
Wean Pct.	50%								
Cow Eff.	105								

★★★★★ for Low Maintenance, Growth, Gainability, Marbling, Calving Ease, Stayability.



73 **BECKTON NEBULA U705 P**
1-A 100% # 1259548 Tattoo: BKT8 U705

Birth: 4-5-08

Beckton Nebula M045
BECKTON NEBULA P P707
 Ref. N-4
 Beckton Lana M809 EP
 Beckton Neptune R2 K065
 Beckton Belga K285 JL
 Beckton Epic K1 K863
 Beckton Lana K253 DM
 Beckton Epic K F075
 Beckton Minerva F495 CH
 Beckton Neptune RT Z305
 Bkt Pine Marie D319 VG
BKT PINE MARIE R213 EP
 Beckton Epic KM M115
 BKT Pine Marie H175 NP

DAM		Calv.Ease	BW	WW	YW	Milk	HPG	Stay	Maint.En.
Age	3	11	-1.4	40	76	16	7	12	-3.4
Wt	970	Marb +0.11		REA +0.02		Bfat +0.01			
Prog.BW	71	BWt	WWt	WR	ADG	YWt	YR	Scr.	Fr.
WR	113	77	636	112	4.80	1192	110	39	5.5
YR	105								
Wean Pct.	61%								
Cow Eff.	129								

★★★★★ for Low Maintenance, Growth, Gainability, Marbling, Superior Cow, High Cow Efficiency, Calving Ease.

71 **BECKTON NEBULA U311 G**
1-A 100% # 1258785 Tattoo: BKT8 U311

Birth: 3-16-08

Beckton Nebula M045
BECKTON NEBULA G S237
 Ref. N-6
 Beckton Lakme LA06 JL
 Beckton Neptune R2 K065
 Beckton Belga K285 JL
 Beckton Julian GG B571
 Beckton Lakme B370 HV
 Beckton Dominor Z E401
 Beckton Barmaid J012 CO
 RDD B Topper 1675
 Bkt Tamara 8195 DN
 Beckton Dominor ZC M919
BECKTON TAMARA S565 DM
 Beckton Tamara F658 TP

DAM		Calv.Ease	BW	WW	YW	Milk	HPG	Stay	Maint.En.
Age	2	12	-1.3	29	60	15	8	14	-5.2
Wt	910	Marb +0.15		REA +0.28		Bfat +0.01			
Prog.BW	71	BWt	WWt	WR	ADG	YWt	YR	Scr.	Fr.
WR	108	71	617	108	4.29	1144	110	37	5.5
YR	110								
Wean Pct.	61%								
Cow Eff.	129								

★★★★★ for Low Maintenance, Gainability, Marbling, Rib-eye area, Superior Cow, High Cow Efficiency, Calving Ease, Stayability. **Selling 1/2 Interest & Full Possession.**

74 **BECKTON NEBULA U734 N**
1-A 100% # 1259511 Tattoo: BKT8 U734

Birth: 4-8-08

Beckton Nebula M045
BECKTON NEBULA N R573
 Ref. N-5
 Beckton Lana M621 LN
 Beckton Neptune R2 K065
 Beckton Belga K285 JL
 Beckton Lancer F442 T
 Beckton Lana H329 HD
 Beckton Cruiser K118
 Beckton Larkaba KA36 HR
 Beckton Clipper KH F416
 Beckton Larkaba F843 JL
BECKTON LARKABA P669 CE
 Beckton Cruiser M210
 Beckton Larkaba H101 CL

DAM		Calv.Ease	BW	WW	YW	Milk	HPG	Stay	Maint.En.
Age	4	9	+1.4	37	65	12	10	13	-0.6
Wt	1055	Marb +0.08		REA +0.05		Bfat -0.01			
Prog.BW	73	BWt	WWt	WR	ADG	YWt	YR	Scr.	Fr.
WR	106	89	643	110	4.08	1178	108	40	5.5
YR	105								
Wean Pct.	59%								
Cow Eff.	124								

★★★★★ for Low Maintenance, Growth, Gainability, Superior Cow, High Cow Efficiency, Calving Ease, Stayability.

• Bulls •

75 BECKTON JUSTICE U213 C1
1-A 100% # 1259395 Tattoo: BKT8 U213

Birth: 3-12-08
 Beckton Justice CH M056
BECKTON JUSTICE C1 R483
 Ref. J-7
 Beckton Tamara J124 HR
 Beckton Justice C K449
 Beckton Ruth K802 HD
 Beckton Herald F FA20
 Beckton Tamara F183 CT
 Buf Crk Coppertop 3230
 Bkt Larkeisa C894 JV
BECKTON MINERVA K370 CO
 Beckton Copper J E616
 Beckton Minerva E932 JL
 Beckton Julian GG B571
 Bkt Minerva 9665 DR

DAM		Calv.Ease	BW	WW	YW	Milk	HPG	Stay	Maint.En.
Age	8	12	-2.7	25	59	17	9	12	-1.1
Wt	990	Marb +1.2		REA -0.7		Bfat +0.0			
Prog.BW	70	BWt	WWt	WR	ADG	YWt	YR	Scr.	Fr.
WR	103	75	558	96	4.54	1136	104	35	5.0
YR	100								
Wean Pct.	56%								
Cow Eff.	119								

★★★★★ for Low Maintenance, Gainability, Marbling, High Cow Efficiency, Calving Ease.

78 BKT CHEROKEE U305 N
1-A 100% # 1258913 Tattoo: WF8 U305

Birth: 3-16-08
 BFCK Cherokee Cnyn 4912
BECKTON CHEROKEE N N479
 Ref. B-1
 Beckton Dinah C440 NM
 Beckton Lancer TS D390
BKT SUFFEINA M613 LN
 BKT Suffeina H693 LN
 BUF CRK Chief 824-1658
 MRM 1431 8611 9109
 Beckton Nomad K 9949
 Beckton Dinah Z610 JL
 Beckton Lancer T A664
 Beckton Coca 7536 SB
 Beckton Lancer T A664
 Bkt Suffeina D164 CL

DAM		Calv.Ease	BW	WW	YW	Milk	HPG	Stay	Maint.En.
Age	6	12	-2.7	32	52	13	9	12	-2.0
Wt	1185	Marb +1.1		REA +0.2		Bfat +0.1			
Prog.BW	74	BWt	WWt	WR	ADG	YWt	YR	Scr.	Fr.
WR	94	80	582	100	4.18	1103	101	38	5.0
YR	101								
Wean Pct.	49%								
Cow Eff.	104								

★★★★★ for Low Maintenance, Gainability, Marbling, Calving Ease.

76 BECKTON JULIAN U104 G5
1-A 100% # 1259137 Tattoo: WF8 U104

Birth: 3-3-08
 Beckton Julian GJ P535
BECKTON JULIAN G5 S107
 Ref. J-8
 Beckton Minola P826 DM
 Beckton Dominor ZC M919
BECKTON MINOLA S674 DM
 Beckton Minola N760 HU
 Beckton Julian 7526G
 Beckton Mona D086 JL
 Beckton Dominor ZC M919
 Beckton Minola M641 WR
 Beckton Dominor Z E401
 Beckton Barmaid J012 CO
 Beckton Hustler CN J102
 Beckton Minola K527 CO

DAM		Calv.Ease	BW	WW	YW	Milk	HPG	Stay	Maint.En.
Age	2	7	+1.2	38	78	15	11	14	-1.7
Wt	895	Marb +1.0		REA +0.4		Bfat +0.0			
Prog.BW	75	BWt	WWt	WR	ADG	YWt	YR	Scr.	Fr.
WR	108	75	615	108	4.69	1142	110	34	5.5
YR	110								
Wean Pct.	62%								
Cow Eff.	131								

★★★★★ for Low Maintenance, Growth, Gainability, Superior Cow, High Cow Efficiency, Calving Ease, Stayability.



77 BECKTON JULIAN U435 G2
1-A 100% # 1259012 Tattoo: WF8 U435

Birth: 3-21-08
 Beckton Julian GG B571
BECKTON JULIAN G2 M345
 Ref.
 Beckton Lana H544 WR
 Beckton Newark Cn N567
BECKTON SIERRA R031 NW
 Beckton Sierra N389 LM
 Beckton Julian 7526G
 Bkt Marta 9A13 JL
 Beckton Warrior TC E801
 Beckton Lana E545 CL
 Beckton Newark C L700
 Beckton Barona L539 NP
 Beckton Laramie L044
 Beckton Sierra L681 HR

DAM		Calv.Ease	BW	WW	YW	Milk	HPG	Stay	Maint.En.
Age	3	14	-1.9	31	65	14	7	12	+0.1
Wt	1040	Marb +1.2		REA +1.2		Bfat -0.1			
Prog.BW	75	BWt	WWt	WR	ADG	YWt	YR	Scr.	Fr.
WR	108	75	617	108	4.34	1166	108	37	5.5
YR	108								
Wean Pct.	55%								
Cow Eff.	117								

★★★★★ for Low Maintenance, Growth, Gainability, Marbling, Superior Cow, High Cow Efficiency, Calving Ease.

79 BECKTON NEBULA U397 L
1-A 100% # 1258967 Tattoo: WF8 U397

Birth: 3-19-08
 Beckton Nebula M045
BECKTON NEBULA L P093
 Ref. N-3
 Beckton Marta M021 LN
 Beckton Justice M M750
BECKTON MINOLA P205 JC
 Beckton Minola M866 LN
 Beckton Neptune R2 K065
 Beckton Belga K285 JL
 Beckton Lancer TA K644
 Beckton Marta K254 LN
 Beckton Justice G302
 Beckton Lana J278 CH
 Beckton Lancer TL G626
 Beckton Minola E625 CL

DAM		Calv.Ease	BW	WW	YW	Milk	HPG	Stay	Maint.En.
Age	4	13	-0.8	39	72	5	8	14	+1.7
Wt	1235	Marb +0.4		REA +4.1		Bfat -0.1			
Prog.BW	67	BWt	WWt	WR	ADG	YWt	YR	Scr.	Fr.
WR	96	72	591	101	4.24	1120	103	33	5.5
YR	99								
Wean Pct.	46%								
Cow Eff.	97								

★★★★★ for Low Maintenance, Gainability, Rib-eye area, Calving Ease, Stayability.

• Bulls •

80 **BECKTON NEBULA U094 G**
1-A 100% # 1259612 Tattoo: BKT8 U094

Birth: 3-1-08
 Beckton Nebula M045
BECKTON NEBULA G S237
 Ref. N-6 Beckton Lakme LA06 JL
 Beckton Neptune R2 K065
 Beckton Belga K285 JL
 Beckton Julian GG B571
 Beckton Lakme B370 HV
 Beckton Jet L P491
BECKTON EOLA S023 JT
 Beckton Eola P336 CE
 TR Julian LT151
 Beckton Minerva L278 LN
 Beckton Cruiser K118
 Beckton Eola C611 SC

DAM		Calv.Ease	BW	WW	YW	Milk	HPG	Stay	Maint.En.
Age	2	14	-1.7	31	60	12	11	15	-2.0
Wt	825	Marb +0.01		REA +0.06		Bfat +0.01			
Prog.BW	72	BWt	WWt	WR	ADG	YWt	YR	Scr.	Fr.
WR	107	72	608	107	3.88	1108	107	34	5.5
YR	107								
Wean Pct.	66%								
Cow Eff.	140								

★★★★★ for Low Maintenance, Superior Cow, High Cow Efficiency, Calving Ease, Stayability.

83 **BECKTON NEBULA U014 E**
1-A 100% # 1258771 Tattoo: BKT8 U014

Birth: 2-15-08
 Beckton Nebula E P084
BECKTON NEBULA EN S347
 Ref. N-7 Beckton Eola P530 NB
 Beckton Nebula M045
 BKT Pine Marie M119 EP
 Beckton Nebula M045
 Beckton Eola M663 EP
 Beckton Julian G1 J526
 Beckton Barona J591 EP
 Beckton Jules L429
BKT PINE MARIE S467 JE
 BKT Pine Marie M119 EP
 Beckton Epic K F075
 Bkt Pine Marie D126 JL

DAM		Calv.Ease	BW	WW	YW	Milk	HPG	Stay	Maint.En.
Age	2	15	-3.9	27	53	13	10	17	-5.1
Wt	810	Marb +0.25		REA +0.04		Bfat +0.01			
Prog.BW	64	BWt	WWt	WR	ADG	YWt	YR	Scr.	Fr.
WR	101	64	573	101	4.13	1058	102	34	5.5
YR	102								
Wean Pct.	63%								
Cow Eff.	133								

★★★★★ for Low Maintenance, Gainability, Marbling, High Cow Efficiency, Calving Ease, Stayability.

81 **BECKTON VEGA U161**
1-A 100% # 1258845 Tattoo: WF8 U161

Birth: 3-9-08
 Beckton Vegas S1 K316
BECKTON VEGA P079
 Ref. V-1 Beckton Lydia H159 JL
 Beckton Vegas SV H078
 Beckton Eola H073 EP
 Beckton Julian GG B571
 Beckton Lydia D386 CL
 Beckton Loki F251
BECKTON RUTH H105 LO
 Beckton Ruth F125 KA
 Beckton Lancer TZ D525
 Bkt Pine Marie D126 JL
 Beckton Kannon D202
 Beckton Ruth D247 KR

DAM		Calv.Ease	BW	WW	YW	Milk	HPG	Stay	Maint.En.
Age	10	11	-0.8	29	52	15	7	13	+0.9
Wt	1075	Marb +0.08		REA +0.18		Bfat +0.00			
Prog.BW	76	BWt	WWt	WR	ADG	YWt	YR	Scr.	Fr.
WR	100	83	597	102	3.88	1098	101	37	5.0
YR	100								
Wean Pct.	56%								
Cow Eff.	117								

★★★★★ for Low Maintenance, Rib-eye area, High Cow Efficiency, Calving Ease, Stayability.

84 **BECKTON NEBULA U266 N**
1-A 100% # 1259397 Tattoo: BKT8 U266

Birth: 3-15-08
 Beckton Nebula M045
BECKTON NEBULA N R573
 Ref. N-5 Beckton Lana M621 LN
 Beckton Neptune R2 K065
 Beckton Belga K285 JL
 Beckton Lancer F442 T
 Beckton Lana H329 HD
 Beckton Copper JT G095
BECKTON COCA K480 CO
 Beckton Coca C178 VG
 Beckton Copper J E616
 Beckton Ruth E549 TP
 Beckton Vegas 9433
 Beckton Coca 8372 TJ

DAM		Calv.Ease	BW	WW	YW	Milk	HPG	Stay	Maint.En.
Age	8	14	-3.3	27	47	12	10	15	-4.6
Wt	1080	Marb +0.17		REA -0.03		Bfat -0.01			
Prog.BW	65	BWt	WWt	WR	ADG	YWt	YR	Scr.	Fr.
WR	98	69	623	101	3.78	1083	98	38	5.0
YR	98								
Wean Pct.	58%								
Cow Eff.	122								

★★★★★ for Low Maintenance, Marbling, High Cow Efficiency, Calving Ease, Stayability.

82 **BKT CHEROKEE U411 N**
1-A 100% # 1259475 Tattoo: BKT8 U411

Birth: 3-20-08
 BFCK Cherokee Cnyn 4912
BECKTON CHEROKEE N N479
 Ref. B-1 Beckton Dinah C440 NM
 Beckton Epic KJ J722
BKT PINE MARIE N719 EP
 BKT Pine Marie H379 LA
 BUF CRK Chief 824-1658
 MRM 1431 8611 9109
 Beckton Nomad K 9949
 Beckton Dinah Z610 JL
 Beckton Epic K F075
 Beckton Lana F891 JL
 Beckton Lancelot F045
 Bkt Pine Marie F599 CD

DAM		Calv.Ease	BW	WW	YW	Milk	HPG	Stay	Maint.En.
Age	5	13	-2.8	33	51	15	10	10	-6.3
Wt	995	Marb +0.07		REA +0.09		Bfat +0.02			
Prog.BW	61	BWt	WWt	WR	ADG	YWt	YR	Scr.	Fr.
WR	97	71	618	106	3.67	1116	102	40	5.0
YR	93								
Wean Pct.	62%								
Cow Eff.	131								

★★★★★ for Low Maintenance, High Cow Efficiency, Calving Ease.

85 **BECKTON ROMAN U002 J**
1-A 100% # 1258802 Tattoo: BKT8 U002

Birth: 2-10-08
 TR Romeo NT379
BECKTON ROMAN J S158
 Ref. J-9 Beckton Belga K285 JL
 Buffalo Creek Romeo L081
 Buf Crk Lass L420
 Beckton Julian GG B571
 Beckton Belga G493 HR
 Beckton Julian GG B571
 Beckton Lana H544 WR
 Beckton Christy L560 EP
BECKTON CHRISTY S704 JL
 Beckton Epic D404
 Beckton Christy G392 LN

DAM		Calv.Ease	BW	WW	YW	Milk	HPG	Stay	Maint.En.
Age	2	13	-0.7	36	64	16	9	16	-1.1
Wt	835	Marb +0.12		REA +0.20		Bfat +0.01			
Prog.BW	67	BWt	WWt	WR	ADG	YWt	YR	Scr.	Fr.
WR	104	67	558	104	3.78	1014	100	34	5.5
YR	100								
Wean Pct.	60%								
Cow Eff.	126								

★★★★★ for Low Maintenance, Marbling, Rib-eye area, High Cow Efficiency, Calving Ease, Stayability.

• Bulls •



88 **TR EPIC UT818**
 1-A 100% # 1240462 Tattoo: TR2A8 UT81

Birth: 2-18-08

Beckton Epic K F075
 Beckton Epic D404
 Beckton Belga D483 KR

BECKTON EPIC KM M115
 Ref. E-1 Beckton Minerva F495 CH
 Beckton Champ R A583
 Beckton Minerva CB69 JL
 Beckton Julian GG B571
 BUF Crk Primrose 5679

TR MINOLA NT309
 BUF Crk Romeo L081
 BUF Crk Minola L387
 BUF Crk Counterchf 5107
 BUF Crk Minola 5001

DAM		Calv.Ease	BW	WW	YW	Milk	HPG	Stay	Maint.En.
Age	5	10	-1.2	35	78	23	8	11	+5.7
Wt	NA								
Prog.BW	83								
WR	112			Marb +.04	REA +.00			Bfat +.02	
YR	115								
Wean Pct.	NA%	BWt	WWt	WR	ADG	YWt	YR	Scr.	Fr.
Cow Eff.	NA	83	656	107	3.62	1235	111	41	5.5

★★★★★ for Growth, Superior Cow, Calving Ease.

86 **BECKTON CHEROKEE U538 N**
 1-A 100% # 1258923 Tattoo: WF8 U538

Birth: 3-24-08

BFCK Cherokee Cnyn 4912
 BUF CRK Chief 824-1658
 MRM 1431 8611 9109

BECKTON CHEROKEE N N479
 Ref. B-1 Beckton Dinah C440 NM
 Beckton Nomad K 9949
 Beckton Dinah Z610 JL

Beckton Warrior TD L493
 Beckton Warrior T C371
 Bkt Suffeina A828 DM

BECKTON LANA N059 WR
 Beckton Lana L665 VG
 Beckton Vegas PK F485
 Beckton Lana F819 NP

DAM		Calv.Ease	BW	WW	YW	Milk	HPG	Stay	Maint.En.
Age	5	12	-2.7	33	53	18	9	9	-0.8
Wt	1045								
Prog.BW	65								
WR	104			Marb +.01	REA +.11			Bfat -.01	
YR	105								
Wean Pct.	59%	BWt	WWt	WR	ADG	YWt	YR	Scr.	Fr.
Cow Eff.	124	73	616	106	3.21	1086	99	37	5.5

★★★★★ for Low Maintenance, Superior Cow, High Cow Efficiency, Calving Ease.

89 **TR JUBILATION UT841**
 1-A 100% # 1240497 Tattoo: TR2A8 UT84

Birth: 2-17-08

Beckton Julian GG B571
 BKT Julian 7526 G
 BKT Marta 9A13 JL

TR JULIAN LT142
 Ref. J-10 TR Lana G760
 Beckton Cody V E023
 Beckton Lana E828 SC

BUF Crk Romeo L081
 Beckton Julian GG B571
 BUF Crk Primrose 5679

THIS OF N441 ROMEO
 Beckton Tamara N441 LN
 Beckton Lancer TH K417
 Beckton Tamara E193 CO

DAM		Calv.Ease	BW	WW	YW	Milk	HPG	Stay	Maint.En.
Age	3	12	-2.3	36	70	20	14	13.5	+0.7
Wt	NA								
Prog.BW	74								
WR	103			Marb +.02	REA +.08			Bfat +.00	
YR	102								
Wean Pct.	NA%	BWt	WWt	WR	ADG	YWt	YR	Scr.	Fr.
Cow Eff.	NA	74	687	103	3.43	1235	102	36	6.5

★★★★★ for Low Maintenance, Calving Ease, Stayability.

87 **BECKTON JORDAN U690**
 1-A 100% # 1258961 Tattoo: WF8 U690

Birth: 4-3-08

TR Julian LT151
 Beckton Julian GG B571
 MS Geometric 917

TR JULIAN RT561
 Ref. J-13 TR Dyna HT824
 Buf Crk Dynamics 3820
 Buf Crk Dyna 3082

Beckton Lancer T6 M467
 Beckton Lancer TL G626
 Beckton Lana C735 TP

BECKTON SIERRA P027 LN
 Beckton Sierra M258 LN
 Beckton Lancer TH K417
 Beckton Sierra K672 EP

DAM		Calv.Ease	BW	WW	YW	Milk	HPG	Stay	Maint.En.
Age	4	10	-0.2	32	57	16	8	12	+3.7
Wt	1070								
Prog.BW	82								
WR	116			Marb +.13	REA -.01			Bfat -.01	
YR	109								
Wean Pct.	60%	BWt	WWt	WR	ADG	YWt	YR	Scr.	Fr.
Cow Eff.	125	86	656	113	3.42	1109	102	36	5.5

★★★★★ for Low Maintenance, Marbling, Superior Cow, High Cow Efficiency, Calving Ease.

90 **TR CODY UT806**
 1-A 100% # 1240434 Tattoo: TR2A8 UT80

Birth: 2-25-08

Beckton Cody C401
 Beckton Clipper JL A095
 Beckton Scarlet A742 RB

BECKTON CODY V E023
 Ref. Beckton Birdie C353 VG
 Beckton Vegas 9433
 BKT Birdie 8967 JL

Beckton Colt G552
 Beckton Clipper KC D400
 Beckton Rose Z519 ZN

BECKTON COCA L388 CK
 Beckton Coca G488 WR
 Beckton Warrior T C371
 Beckton Coca D185 RD

DAM		Calv.Ease	BW	WW	YW	Milk	HPG	Stay	Maint.En.
Age	7	12	-1.1	31	70	13	13	6.4	+5.4
Wt	NA								
Prog.BW	73								
WR	98			Marb +.14	REA +.12			Bfat +.00	
YR	105								
Wean Pct.	NA%	BWt	WWt	WR	ADG	YWt	YR	Scr.	Fr.
Cow Eff.	NA	81	672	110	3.58	1246	112	40	5.0

★★★★★ for Growth, Marbling, Calving Ease.

• Bulls •

91 **TR JADE UT819**
1-A 100% # 1240461 Tattoo: TR2A8 UT81

Birth: 3-10-08

Beckton Julian GG B571
BKT Julian 7526 G
BKT Marta 9A13 JL

TR JULIAN ST630
Ref. J-14 MS Geometric 003
BJR Make My Day 981
MS Geometric 277

Beckton Julian GG B571
BUF Crk Primrose 5679

TR PINEMARIE NT311
BUF Crk Romeo L081
BUF Crk PineMarie L279
BUF Crk Iowa 2886
BUF Crk PineMarie 4987

DAM		Calv.Ease	BW	WW	YW	Milk	HPG	Stay	Maint.En.
Age	5	14	-3.2	31	58	16	12	14.2	+3.9
Wt	NA								
Prog.BW	82								
WR	109		Marb +.16		REA +.24		Bfat +.01		
YR	106								
Wean Pct.	NA%	BWt	WWt	WR	ADG	YWt	YR	Scr.	Fr.
Cow Eff.	NA	78	690	112	3.05	1178	106	37	6.0

★★★★★ for Low Maintenance, Marbling, Rib-eye area, Superior Cow, Calving Ease, Stayability.

93 **BSF CLIFFTOP U437 TP**
1-B 99% # 1259230 Tattoo: BSF8 U437

Birth: 3-21-08

Beckton Clifftop T C075
BJR Topper 5241
Beckton Barmaid A761 TR

BKT CLIFFTOP TP R288
Ref. B-3 Beckton Christy K209 CO
Beckton Copper JT G095
Beckton Christy A111 VQ

Beckton Loki F251
Beckton Lancer TZ D525
Bkt Pine Marie D126 JL

BSF LAUREL N411 LO
BSF Regus G195
Beckton Emperor C369
BSF Regus 8099

DAM		Calv.Ease	BW	WW	YW	Milk	HPG	Stay	Maint.En.
Age	5	13	-4.6	20	47	16	7	13	-5.6
Wt	1015								
Prog.BW	69								
WR	98		Marb +.08		REA +.17		Bfat +.00		
YR	99								
Wean Pct.	58%	BWt	WWt	WR	ADG	YWt	YR	Scr.	Fr.
Cow Eff.	122	69	588	101	4.64	1154	106	36	5.0

★★★★★ for Low Maintenance, Gainability, Rib-eye area, High Cow Efficiency, Calving Ease, Stayability.

92 **TR EPIC UT844**
1-A 100% # 1240503 Tattoo: TR2A8 UT84

Birth: 2-14-08

Beckton Epic K F075
Beckton Epic D404
Beckton Belga D483 KR

BECKTON EPIC KM M115
Ref. E-1 Beckton Minerva F495 CH
Beckton Champ R A583
Beckton Minerva CB69 JL

TR Julian PT420
TR Julian LT151
BUF Crk Carrie L349

TR CHRISTY ST667
Beckton Christy L543 JL
Beckton Julian J153 G
Beckton Christy D409 NM

DAM		Calv.Ease	BW	WW	YW	Milk	HPG	Stay	Maint.En.
Age	2	11	-2.6	34	68	18	7	11.7	+4.8
Wt	NA								
Prog.BW	75								
WR	97		Marb +.05		REA +.01		Bfat +.01		
YR	98								
Wean Pct.	NA%	BWt	WWt	WR	ADG	YWt	YR	Scr.	Fr.
Cow Eff.	NA	75	648	97	3.43	1197	98	37	6.0

★★★★★ for Calving Ease.

94 **BSF EPIC U644 KM**
1-B 99% # 1259204 Tattoo: BSF8 U644

Birth: 3-30-08

Beckton Epic K F075
Beckton Epic D404
Beckton Belga D483 KR

BECKTON EPIC KM M115
Ref. E-1 Beckton Minerva F495 CH
Beckton Champ R A583
Beckton Minerva CB69 JL

Beckton Cody K G701
Beckton Cody C401
Beckton Christy B007 KR

BSF REGUS M352 CD
BSF Regus E738
Beckton Neptune RT Z305
BSF Regus Z233

DAM		Calv.Ease	BW	WW	YW	Milk	HPG	Stay	Maint.En.
Age	6	12	-3.3	34	63	15	6	9	-1.6
Wt	1085								
Prog.BW	67								
WR	97		Marb +.05		REA -.13		Bfat +.02		
YR	97								
Wean Pct.	62%	BWt	WWt	WR	ADG	YWt	YR	Scr.	Fr.
Cow Eff.	131	68	674	110	4.39	1171	106	41	5.5

★★★★★ for Low Maintenance, Growth, Gainability, High Cow Efficiency, Calving Ease.



95 **BSF CODY U336 K2**
1-B 99% # 1259209 Tattoo: BSF8 U336

Birth: 3-17-08

Beckton Cody KH M390
Beckton Cody K G701
Beckton Tamara J124 HR

BECKTON CODY K2 R168
Ref. C-2 Beckton Tamara K249 VG
Beckton Vegas SV H078
Beckton Tamara HA38 WR

Beckton Epic D404
Beckton Saga KJ B702
Beckton Kuruba B508 PC

BSF REGUS M563 EP
BSF Regus J754
Beckton Loki F251
BSF Regus E799

DAM		Calv.Ease	BW	WW	YW	Milk	HPG	Stay	Maint.En.
Age	6	12	-2.8	32	62	16	6	10	-2.8
Wt	1085								
Prog.BW	67								
WR	103		Marb +.05		REA -.05		Bfat +.01		
YR	102								
Wean Pct.	57%	BWt	WWt	WR	ADG	YWt	YR	Scr.	Fr.
Cow Eff.	119	75	614	104	4.44	1135	100	36	5.0

★★★★★ for Low Maintenance, Gainability, High Cow Efficiency, Calving Ease.

• Bulls •

96 **BSF HALLMARK U200**
1-B 99% # 1259256 Tattoo: BSF8 U200

Birth: 3-12-08
 Beckton Hustler CN J102
BECKTON HALFMANNHUSTLER R588
 Ref. H-2
 Beckton Vernice F513 CL
 Beckton Hustler C G407
 Beckton Belga G355 NP
 Beckton Clipper JM A124
 Beckton Vernice A663 PC
 Beckton Lancer TZ D525
 Beckton Vernice D121 VG
 Beckton Justice G302
 BSF Regus F165
 Beckton Lancer T4 J536
BSF LANETTE P782
 BSF Regus K432 JC

DAM		Calv.Ease	BW	WW	YW	Milk	HPG	Stay	Maint.En.
Age	4	18	-6.8	23	60	10	9	10	+3.2
Wt	1075								
Prog.BW	55								
WR	98			Marb	-0.01	REA	+0.19	Bfat	-0.02
YR	102								
Wean Pct.	50%	BWt	WWt	WR	ADG	YWt	YR	Scr.	Fr.
Cow Eff.	105	56	558	96	4.85	1166	107	34	5.0

★★★★★ for Low Maintenance, Gainability, Rib-eye area, Calving Ease.

99 **BSF JORDAN U831**
1-B 99% # 1259271 Tattoo: BSF8 U831

Birth: 4-22-08
 TR Julian LT151
TR JULIAN RT561
 Ref. J-13
 TR Dyna HT824
 Beckton Julian GG B571
 MS Geometric 917
 Buf Crk Dynamics 3820
 Buf Crk Dyna 3082
 Beckton Champ RH F275
 Beckton Lana F138 LN
 Beckton Warrior C C355
 BSF Regus J498
 Beckton Champ R1 H024
BSF CHAMPALA R278 CH
 BSF Regus M712 WR

DAM		Calv.Ease	BW	WW	YW	Milk	HPG	Stay	Maint.En.
Age	3	10	-0.4	36	70	15	8	12	+4.8
Wt	1100								
Prog.BW	79								
WR	109			Marb	+0.04	REA	+0.17	Bfat	-0.02
YR	109								
Wean Pct.	56%	BWt	WWt	WR	ADG	YWt	YR	Scr.	Fr.
Cow Eff.	117	81	650	114	4.49	1233	114	37	5.5

★★★★★ for Growth, Gainability, Rib-eye area, Superior Cow, High Cow Efficiency, Calving Ease.

97 **BSF JORDAN U787**
1-B 99% # 1259213 Tattoo: BSF8 U787

Birth: 4-14-08
 TR Julian LT151
TR JULIAN RT561
 Ref. J-13
 TR Dyna HT824
 Beckton Epic K F075
BSF REGUS M644 EP
 BKT Regus H285
 Beckton Julian GG B571
 MS Geometric 917
 Buf Crk Dynamics 3820
 Buf Crk Dyna 3082
 Beckton Epic D404
 Beckton Belga D483 KR
 BSF Casper F784
 Bkt Larkeisa F637 CL

DAM		Calv.Ease	BW	WW	YW	Milk	HPG	Stay	Maint.En.
Age	6	11	-1.9	30	65	14	10	11	-1.9
Wt	1065								
Prog.BW	75								
WR	104			Marb	+0.13	REA	+0.08	Bfat	+0.01
YR	104								
Wean Pct.	60%	BWt	WWt	WR	ADG	YWt	YR	Scr.	Fr.
Cow Eff.	126	84	639	110	4.59	1215	111	39	5.0

★★★★★ for Low Maintenance, Growth, Gainability, Marbling, Superior Cow, High Cow Efficiency, Calving Ease.



98 **BSF EPIC U245 K4**
1-B 99% # 1259202 Tattoo: BSF8 U245

Birth: 3-14-08
 Beckton Epic KJ J722
BECKTON EPIC K4 N795
 Ref. E-2
 Beckton Sierra J789 EP
 Beckton Epic K F075
 Beckton Lana F891 JL
 Beckton Epic D404
 Beckton Sierra C157 CL
 Beckton Champ RH F275
 Beckton Lana F138 LN
 Beckton Clipper JL A095
 BSF Regus 8341
 Beckton Champ R1 H024
BSF REGUS M133 CH
 BSF Red D116

DAM		Calv.Ease	BW	WW	YW	Milk	HPG	Stay	Maint.En.
Age	6	11	-2.1	29	61	15	7	9	-0.7
Wt	1160								
Prog.BW	68								
WR	108			Marb	+0.06	REA	+0.13	Bfat	-0.01
YR	106								
Wean Pct.	50%	BWt	WWt	WR	ADG	YWt	YR	Scr.	Fr.
Cow Eff.	106	72	585	100	3.37	1105	101	38	5.5

★★★★★ for Low Maintenance, Rib-eye area, Superior Cow, Calving Ease.

100 **BSF JULIAN U594 G3**
2 99% # 1259242 Tattoo: BSF8 U594

Birth: 3-27-08
 Beckton Julian GG B571
BECKTON JULIAN G3 P608
 Ref. J-6
 Bkt Suffeina A828 DM
 Beckton Julian 7526G
 Bkt Marta 9A13 JL
 Beckton Dominor 9455
 Bkt Suffeina 9493 TT
 Beckton Lancer TL G626
 Beckton Lana C735 TP
 Beckton Champ R3 H338
 BSF Regus J306
 Beckton Lancer T6 M467
BSF LANETTE P177
 BSF Regus M383 CH

DAM		Calv.Ease	BW	WW	YW	Milk	HPG	Stay	Maint.En.
Age	4	17	-6.0	15	45	15	9	15	-3.4
Wt	985								
Prog.BW	61								
WR	108			Marb	+0.08	REA	+0.05	Bfat	+0.01
YR	107								
Wean Pct.	56%	BWt	WWt	WR	ADG	YWt	YR	Scr.	Fr.
Cow Eff.	118	65	572	98	4.34	1132	104	34	5.0

★★★★★ for Low Maintenance, Gainability, Superior Cow, High Cow Efficiency, Calving Ease, Stayability.

• Bulls •

101 **BSF JORDAN U541**
1-B 99% # 1259282 Tattoo: BSF8 U541

Birth: 3-24-08
 TR Julian RT561 (TR Julian LT151)
 Ref. J-13 (TR Dyna HT824)
 BSF JEWEL R614 LS (Beckton Laser N602)
 (BSF Jewel N039 JO)
 Beckton Julian GG B571 (MS Geometric 917)
 Beckton Lancer F442 T (Beckton Minola E589 TO)
 Beckton Julio L233 (BSF Regus L013 CT)

DAM		Calv.Ease	BW	WW	YW	Milk	HPG	Stay	Maint.En.
Age	3	15	-4.2	25	53	14	9	15	-3.5
Wt	860	Marb +0.14		REA +0.11		Bfat -0.01			
Prog.BW	67	BWt	WWt	WR	ADG	YWt	YR	Scr.	Fr.
WR	110	63	606	106	4.49	1133	105	35	5.5
YR	108								
Wean Pct.	66%								
Cow Eff.	139								

★★★★★ for Low Maintenance, Gainability, Marbling, Superior Cow, High Cow Efficiency, Calving Ease, Stayability.

104 **BKT CLIFFTOP U622 TP**
1-A 100% # 1258978 Tattoo: WF8 U622

Birth: 3-29-08
 BKT CLIFFTOP TP R288 (Beckton Clifftop T C075)
 Ref. B-3 (Beckton Christy K209 CO)
 BECKTON COCA P440 JL (Beckton Julian GG B571)
 (Beckton Coca K498 HR)
 BJR Topper 5241 (Beckton Barmaid A761 TR)
 Beckton Copper JT G095 (Beckton Christy A111 VQ)
 Beckton Julian 7526G (Bkt Marta 9A13 JL)
 Beckton Herald HH E503 (Beckton Coca C605 VG)

DAM		Calv.Ease	BW	WW	YW	Milk	HPG	Stay	Maint.En.
Age	4	14	-2.8	34	55	17	9	14	-2.2
Wt	1035	Marb +0.04		REA +0.19		Bfat +0.00			
Prog.BW	74	BWt	WWt	WR	ADG	YWt	YR	Scr.	Fr.
WR	112	76	680	117	3.78	1148	105	35	5.0
YR	100								
Wean Pct.	64%								
Cow Eff.	134								

★★★★★ for Low Maintenance, Rib-eye area, High Cow Efficiency, Calving Ease, Stayability.

102 **BSF CODY U679 K1**
1-B 88% # 1259201 Tattoo: BSF8 U679

Birth: 4-2-08
 BECKTON CODY K1 P014 (Beckton Cody KH M390)
 Ref. C-1 (Beckton Rose M126 WR)
 BSF RED M104 LN (Beckton Lancer F442 T)
 (BRU Red HC67)
 Beckton Cody K G701 (Beckton Tamara J124 HR)
 Beckton Warrior T C371 (Beckton Rose D741 LN)
 Beckton Lancer T A664 (Bkt Suffeina A828 DM)
 Beckton Cobalt V AC03

DAM		Calv.Ease	BW	WW	YW	Milk	HPG	Stay	Maint.En.
Age	6	10	-1.0	24	54	13	7	10	+0.9
Wt	1280	Marb -0.02		REA +0.21		Bfat -0.01			
Prog.BW	70	BWt	WWt	WR	ADG	YWt	YR	Scr.	Fr.
WR	94	83	550	93	4.29	1114	98	37	5.5
YR	104								
Wean Pct.	43%								
Cow Eff.	91								

★★★★★ for Low Maintenance, Gainability, Rib-eye area, Calving Ease.

105 **BKT CLIFFTOP U425 TP**
1-A 100% # 1258942 Tattoo: WF8 U425

Birth: 3-21-08
 BKT CLIFFTOP TP R288 (Beckton Clifftop T C075)
 Ref. B-3 (Beckton Christy K209 CO)
 BECKTON INDIGO N467 LO (Beckton Loki F251)
 (Beckton Indigo H150 LN)
 BJR Topper 5241 (Beckton Barmaid A761 TR)
 Beckton Copper JT G095 (Beckton Christy A111 VQ)
 Beckton Lancer TZ D525 (Bkt Pine Marie D126 JL)
 Beckton Lancer TE F363 (Beckton Indigo F376 CT)

DAM		Calv.Ease	BW	WW	YW	Milk	HPG	Stay	Maint.En.
Age	5	10	-0.1	34	60	15	6	14	+0.2
Wt	1180	Marb +0.14		REA +0.07		Bfat -0.01			
Prog.BW	75	BWt	WWt	WR	ADG	YWt	YR	Scr.	Fr.
WR	103	87	654	106	3.83	1122	101	37	5.0
YR	109								
Wean Pct.	55%								
Cow Eff.	117								

★★★★★ for Low Maintenance, Marbling, Superior Cow, High Cow Efficiency, Calving Ease, Stayability.

103 **BECKTON EPIC U368 KM**
1-A 100% # 1258898 Tattoo: WF8 U368

Birth: 3-18-08
 BECKTON EPIC KM M115 (Beckton Epic K F075)
 Ref. E-1 (Beckton Minerva F495 CH)
 BECKTON BELGA M050 EP (Beckton Epic K1 K863)
 (Beckton Belga K588 HD)
 Beckton Epic D404 (Beckton Belga D483 KR)
 Beckton Champ RA583 (Beckton Minerva CB69 JL)
 Beckton Epic KN H110 (Beckton Rose H019 SC)
 Beckton Hadrian F C486 (Beckton Belga C506 HB)

DAM		Calv.Ease	BW	WW	YW	Milk	HPG	Stay	Maint.En.
Age	6	13	-3.5	30	61	23	7	10	-2.2
Wt	985	Marb +0.07		REA -0.06		Bfat +0.01			
Prog.BW	64	BWt	WWt	WR	ADG	YWt	YR	Scr.	Fr.
WR	110	66	608	104	4.18	1140	104	36	5.0
YR	102								
Wean Pct.	62%								
Cow Eff.	130								

★★★★★ for Low Maintenance, Gainability, High Cow Efficiency, Calving Ease.

106 **BECKTON JULIAN U494 GJ**
1-A 100% # 1259457 Tattoo: BKT8 U494

Birth: 3-23-08
 BECKTON JULIAN GJ P535 (Beckton Julian 7526G)
 Ref. J-5 (Beckton Mona D086 JL)
 BECKTON LYDIA N081 WR (Beckton Warrior TD L493)
 (Beckton Lydia L625 WR)
 Beckton Julian 6592 (Bkt Belga 6746 GS)
 Beckton Julian GV Z693 (Beckton Mona 9356 KR)
 Beckton Warrior T C371 (Bkt Suffeina A828 DM)
 Beckton Warrior C C355 (Beckton Lydia G059 WR)

DAM		Calv.Ease	BW	WW	YW	Milk	HPG	Stay	Maint.En.
Age	5	14	-4.3	28	58	7	12	12	-0.9
Wt	1035	Marb +0.08		REA +0.01		Bfat -0.01			
Prog.BW	66	BWt	WWt	WR	ADG	YWt	YR	Scr.	Fr.
WR	102	65	619	106	4.24	1115	102	37	5.0
YR	105								
Wean Pct.	60%								
Cow Eff.	126								

★★★★★ for Low Maintenance, Gainability, High Cow Efficiency, Calving Ease.

• Bulls •



109 **BECKTON JULIAN U722 GJ**
1-A 100% # 1259372 Tattoo: BKT8 U722

Birth: 4-6-08
 ↙ Beckton Julian 7526G ↘ Beckton Julian 6592
 ↙ Beckton Julian GJ P535 ↘ Bkt Belga 6746 GS
 Ref. J-5 ↙ Beckton Mona D086 JL ↘ Beckton Julian GV Z693
 ↙ Beckton Julian GG B571 ↘ Beckton Mona 9356 KR
BECKTON TAMARA G570 JL ↙ Beckton Julian 7526G ↘ Bkt Marta 9A13 JL
 ↙ Beckton Tamara C931 CL ↘ Beckton Clipper JB A559
 ↘ Beckton Tamara A553 LN

DAM		Calv.Ease	BW	WW	YW	Milk	HPG	Stay	Maint.En.
Age	11	18	-4.8	29	53	6	13	17	-6.7
Wt	1095								
Prog.BW	65								
WR	105								
YR	99								
Wean Pct.	60%								
Cow Eff.	127								
		BWt	WWt	WR	ADG	YWt	YR	Scr.	Fr.
		66	679	111	3.88	1163	105	37	5.0

★★★★★ for Low Maintenance, Rib-eye area, High Cow Efficiency, Calving Ease, Stayability. **Selling ½ Interest & Full Possession.**

107 **BECKTON EMCEE U080**
1-A 100% # 1258803 Tattoo: BKT8 U080

Birth: 2-28-08
 ↙ Beckton Epic K4 N795 ↘ Beckton Epic KJ J722
BECKTON EMCEE S466 ↙ Beckton Sierra J789 EP
 Ref. E-4 ↙ Beckton Larkaba H798 WR ↘ Beckton Warrior T C371
 ↙ Beckton Larkaba E042 CD ↘ Beckton Larkaba H798 WR
 ↙ Beckton Champ R1 H024 ↘ Beckton Champ RH F275
BECKTON TAMARA S708 CH ↙ Beckton Lana F138 LN
 ↙ Beckton Tamara L801 CL ↘ Beckton Clipper KH F416
 ↘ Beckton Tamara H625 CH

DAM		Calv.Ease	BW	WW	YW	Milk	HPG	Stay	Maint.En.
Age	2	10	-1.3	34	64	18	7	10	-0.1
Wt	840								
Prog.BW	72								
WR	112								
YR	107								
Wean Pct.	64%								
Cow Eff.	135								
		BWt	WWt	WR	ADG	YWt	YR	Scr.	Fr.
		72	600	112	4.03	1084	107	32	5.5

★★★★★ for Low Maintenance, Growth, Gainability, Rib-eye area, Superior Cow, High Cow Efficiency, Calving Ease.

110 **BECKTON JULIAN U224 GJ**
1-A 100% # 1259431 Tattoo: BKT8 U224

Birth: 3-13-08
 ↙ Beckton Julian 7526G ↘ Beckton Julian 6592
BECKTON JULIAN GJ P535 ↙ Bkt Belga 6746 GS
 Ref. J-5 ↙ Beckton Mona D086 JL ↘ Beckton Julian GV Z693
 ↙ Beckton Lancer T4 J536 ↘ Beckton Mona 9356 KR
BECKTON SIERRA M220 LN ↙ Beckton Lancer TZ D525
 ↙ Beckton Sierra F719 CD ↘ Beckton Vernice D121 VG
 ↘ Beckton Cody C401
 ↘ Beckton Sierra B006 JV

DAM		Calv.Ease	BW	WW	YW	Milk	HPG	Stay	Maint.En.
Age	6	16	-4.4	27	50	8	10	13	-1.6
Wt	1040								
Prog.BW	64								
WR	104								
YR	99								
Wean Pct.	58%								
Cow Eff.	122								
		BWt	WWt	WR	ADG	YWt	YR	Scr.	Fr.
		67	602	103	3.83	1061	97	36	5.0

★★★★★ for Low Maintenance, Marbling, High Cow Efficiency, Calving Ease, Stayability. **Selling ½ Interest & Full Possession.**

108 **BECKTON EPIC U163 K4**
1-A 100% # 1259490 Tattoo: BKT8 U163

Birth: 3-10-08
 ↙ Beckton Epic KJ J722 ↘ Beckton Epic K F075
BECKTON EPIC K4 N795 ↙ Beckton Lana F891 JL
 Ref. E-2 ↙ Beckton Sierra J789 EP ↘ Beckton Epic D404
 ↙ Beckton Sierra C157 CL ↘ Beckton Sierra C157 CL
 ↙ Beckton Lancer T5 L095 ↘ Beckton Lancer F442 T
BECKTON ROSE P269 LN ↙ Beckton Belga J293 HR
 ↙ Beckton Rose F306 JL ↘ Beckton Julian GG B571
 ↘ Beckton Rose C320 JV

DAM		Calv.Ease	BW	WW	YW	Milk	HPG	Stay	Maint.En.
Age	4	11	-1.0	30	61	11	9	13	+2.6
Wt	1045								
Prog.BW	73								
WR	98								
YR	97								
Wean Pct.	53%								
Cow Eff.	111								
		BWt	WWt	WR	ADG	YWt	YR	Scr.	Fr.
		81	572	98	4.24	1090	100	37	5.0

★★★★★ for Low Maintenance, Gainability, Rib-eye area, Calving Ease, Stayability.

111 **BECKTON EPIC U008 K6**
1-A 100% # 1259100 Tattoo: WF8 U008

Birth: 2-14-08
 ↙ Beckton Epic KM M115 ↘ Beckton Epic K F075
BECKTON EPIC K6 S569 ↙ Beckton Minerva F495 CH
 Ref. E-5 ↙ Beckton Sierra N703 LM ↘ Beckton Laramie L044
 ↙ Beckton Nebula P P707 ↘ Beckton Sierra L887 LN
BECKTON LARKABA S296 NB ↙ Beckton Nebula M045
 ↙ Beckton Larkaba P129 CH ↘ Beckton Lana M809 EP
 ↘ Beckton Champ R3 H338
 ↘ Beckton Larkaba G311 CT

DAM		Calv.Ease	BW	WW	YW	Milk	HPG	Stay	Maint.En.
Age	2	13	-3.3	34	67	17	6	12	-1.3
Wt	750								
Prog.BW	63								
WR	103								
YR	102								
Wean Pct.	65%								
Cow Eff.	138								
		BWt	WWt	WR	ADG	YWt	YR	Scr.	Fr.
		63	550	103	4.24	1037	102	36	5.0

★★★★★ for Low Maintenance, Gainability, Marbling, High Cow Efficiency, Calving Ease.

• Bulls •

112 BECKTON NOMAD U552 V

1-A 100% # 1259028 Tattoo: WF8 U552

Birth: 3-25-08

Beckton Nomad 7496
 Beckton Neva 5562
 Bkt Bolt Tamrck 3913

BECKTON NOMAD V 9871
 Ref. Beckton Varo 5642
 Bkt Lahrogno-3

Beckton Cherokee N N479
 BFCK Cherokee Cnyn 4912
 Beckton Dinah C440 NM

BECKTON MONA R198 CQ
 Beckton Monna N009 JE
 Beckton Jules L429
 Beckton Monna L618 LR

DAM		Calv.Ease	BW	WW	YW	Milk	HPG	Stay	Maint.En.
Age	3	15	-4.0	27	39	14	7	12	-11.1
Wt	950								
Prog.BW	63								
WR	114								
YR	105								
Wean Pct.	65%								
Cow Eff.	138								
		Marb	+13		REA	+06		Bfat +02	
		BWt	WWt	WR	ADG	YWt	YR	Scr.	Fr.
		71	661	114	3.83	1129	105	35	5.0

★★★★★ for Low Maintenance, Marbling, Superior Cow, High Cow Efficiency, Calving Ease.

114 BECKTON EPIC U537 KD

1-A 100% # 1259592 Tattoo: BKT8 U537

Birth: 3-24-08

Beckton Epic K F075
 Beckton Epic D404
 Beckton Belga D483 KR

BECKTON EPIC R350 K
 Ref. E-3 Beckton Larkaba E042 CD
 Beckton Cody C401
 Beckton Larkaba C317 CL

Beckton Lancer T7 M089
 Beckton Lancer F442 T
 Beckton Tamara G141 HE

BECKTON LAKME R626 LN
 Beckton Lakme M669 EP
 Beckton Epic K F075
 Beckton Lakme F560 TP

DAM		Calv.Ease	BW	WW	YW	Milk	HPG	Stay	Maint.En.
Age	3	9	-2.1	32	61	16	10	9	+1.7
Wt	1070								
Prog.BW	76								
WR	109								
YR	102								
Wean Pct.	55%								
Cow Eff.	116								
		Marb	+07		REA	+07		Bfat +01	
		BWt	WWt	WR	ADG	YWt	YR	Scr.	Fr.
		76	629	109	3.98	1099	102	38	5.5

★★★★★ for Low Maintenance, High Cow Efficiency, Calving Ease.

113 BECKTON JUNO U402

1-A 100% # 1259489 Tattoo: BKT8 U402

Birth: 3-20-08

Beckton Julian G1 J526
 Beckton Julian GG B571
 Beckton Annie F743 LN

BECKTON JUNO N493
 Ref. Beckton Serena D760 KR
 Beckton Kaiser FD 9253
 Beckton Serena A420 MB

Beckton Vegas S1 K316
 Beckton Vegas SV H078
 Beckton Eola H073 EP

BECKTON LARKEISA P268 VG
 BKT Larkeisa K053 HR
 Beckton Herald H1 H348
 BKT Larkeisa H443 DM

DAM		Calv.Ease	BW	WW	YW	Milk	HPG	Stay	Maint.En.
Age	4	14	-4.1	32	49	14	7	10	+0.4
Wt	1015								
Prog.BW	67								
WR	109								
YR	108								
Wean Pct.	61%								
Cow Eff.	129								
		Marb	+07		REA	-05		Bfat -.01	
		BWt	WWt	WR	ADG	YWt	YR	Scr.	Fr.
		67	641	104	3.47	1102	99	36	5.0

★★★★★ for Low Maintenance, Superior Cow, High Cow Efficiency, Calving Ease.

115 BECKTON LANCER U421 TD

1-A 100% # 1259408 Tattoo: BKT8 U421

Birth: 3-20-08

Beckton Lancer T A664
 Beckton Lancer 9380
 Beckton Coca 9119 TJ

BECKTON LANCER F442 T
 Ref. L-1 Bkt Suffeina A828 DM
 Beckton Dominor 9455
 Bkt Suffeina 9493 TT

Beckton Lancer TS D390
 Beckton Lancer T A664
 Beckton Coca 7536 SB

BECKTON MINERVA L278 LN
 Beckton Minerva F495 CH
 Beckton Champ R A583
 Beckton Minerva CB69 JL

DAM		Calv.Ease	BW	WW	YW	Milk	HPG	Stay	Maint.En.
Age	7	10	-1.4	27	44	13	4	13	-1.5
Wt	1110								
Prog.BW	74								
WR	104								
YR	103								
Wean Pct.	54%								
Cow Eff.	113								
		Marb	+12		REA	+15		Bfat -.02	
		BWt	WWt	WR	ADG	YWt	YR	Scr.	Fr.
		82	594	102	3.98	1070	98	37	5.0

★★★★★ for Low Maintenance, Marbling, Rib-eye area, Superior Cow, Calving Ease, Stayability.



116 BECKTON LOKI U087 CL

1-A 100% # 1259103 Tattoo: WF8 U087

Birth: 2-29-08

Beckton Loki C M740
 Beckton Loki F251
 BKT Larkeisa J051 CK

BECKTON LOKI CL S284
 Ref. L-3 Beckton Lakme J460 LT
 Beckton Latigo G714
 Beckton Lakme G128 HD

Beckton Loki C M740
 Beckton Loki F251
 BKT Larkeisa J051 CK

BECKTON ENCINO S303 LO
 Beckton Encino N076 PG
 Andras Pure Gold 132
 Beckton Encino L922 CH

DAM		Calv.Ease	BW	WW	YW	Milk	HPG	Stay	Maint.En.
Age	2	11	-1.1	39	67	17	10	13	+3.7
Wt	905								
Prog.BW	70								
WR	109								
YR	102								
Wean Pct.	62%								
Cow Eff.	130								
		Marb	+03		REA	-12		Bfat +00	
		BWt	WWt	WR	ADG	YWt	YR	Scr.	Fr.
		70	619	109	4.03	1053	102	33	5.5

★★★★★ for Low Maintenance, Gainability, High Cow Efficiency, Calving Ease, Stayability.

• Bulls •

117 BECKTON CODY U516 K2

1-A 100% # 1259031 Tattoo: WF8 U516

Birth: 3-24-08

Beckton Cody KH M390
BECKTON CODY K2 R168
 Ref. C-2
 Beckton Tamara K249 VG

Beckton Cody K G701
 Beckton Tamara J124 HR
 Beckton Vegas SV H078
 Beckton Tamara HA38 WR
 Buffalo Creek Romeo L081
 Buf Crk Lass L420

TR Romeo NT379
BECKTON LANA R214 RA
 Beckton Lana N664 JL
 Beckton Julian G1 J526
 Beckton Lana H533 LN

DAM		Calv.Ease	BW	WW	YW	Milk	HPG	Stay	Maint.En.
Age	3	14	-3.7	35	62	20	8	12	-3.4
Wt	780	Marb +0.03		REA +1.10		Bfat +0.01			
Prog.BW	67	BWt	WWt	WR	ADG	YWt	YR	Scr.	Fr.
WR	117	62	670	116	3.37	1096	102	38	5.5
YR	110								
Wean Pct.	81%								
Cow Eff.	170								

★★★★★ for Low Maintenance, Superior Cow, High Cow Efficiency, Calving Ease.

120 BECKTON NEBULA U681 L

1-A 100% # 1259483 Tattoo: BKT8 U681

Birth: 4-2-08

Beckton Nebula M045
BECKTON NEBULA L P093
 Ref. N-3
 Beckton Marta M021 LN

Beckton Neptune R2 K065
 Beckton Belga K285 JL
 Beckton Lancer TA K644
 Beckton Marta K254 LN
 Beckton Neptune R2 K065
 Beckton Belga K285 JL
 Beckton Lancer T3 J396
 Beckton Eola H073 EP

DAM		Calv.Ease	BW	WW	YW	Milk	HPG	Stay	Maint.En.
Age	4	16	-5.1	27	61	7	8	14	-4.6
Wt	1005	Marb +0.07		REA +0.22		Bfat -0.01			
Prog.BW	61	BWt	WWt	WR	ADG	YWt	YR	Scr.	Fr.
WR	97	63	571	98	4.34	1127	103	38	5.5
YR	101								
Wean Pct.	55%								
Cow Eff.	115								

★★★★★ for Low Maintenance, Gainability, Rib-eye area, Calving Ease, Stayability.

118 BECKTON NEBULA U809 N

1-A 100% # 1259578 Tattoo: BKT8 U809

Birth: 4-18-08

Beckton Nebula M045
BECKTON NEBULA N R573
 Ref. N-5
 Beckton Lana M621 LN

Beckton Neptune R2 K065
 Beckton Belga K285 JL
 Beckton Lancer F442 T
 Beckton Lana H329 HD
 Beckton Epic K F075
 Beckton Minerva F495 CH
 Beckton Epic KJ J722
 Beckton Minerva H394 CL

DAM		Calv.Ease	BW	WW	YW	Milk	HPG	Stay	Maint.En.
Age	3	13	-3.2	30	67	14	7	12	-1.1
Wt	1010	Marb +0.16		REA +0.01		Bfat +0.00			
Prog.BW	67	BWt	WWt	WR	ADG	YWt	YR	Scr.	Fr.
WR	106	65	613	108	4.49	1181	109	38	5.5
YR	110								
Wean Pct.	57%								
Cow Eff.	120								

★★★★★ for Low Maintenance, Growth, Gainability, Marbling, Superior Cow, High Cow Efficiency, Calving Ease.



119 BECKTON SCAMP U614 T

1-A 100% # 1259608 Tattoo: BKT8 U614

Birth: 3-28-08

Beckton Scamp 8954
BECKTON SCAMP T A825
 Ref.
 Bkt Encino 8459 TJ

Beckton Justice CH M056
BECKTON TAMARA R834 JC
 Beckton Tamara J229 NP

Beckton Julian 7526G
 Bkt Kusi Annie 5462
 Beckton Trojan 7061P
 BCH Kit 7132-784
 Beckton Justice C K449
 Beckton Ruth K802 HD
 Beckton Neptune RR B284
 Beckton Tamara C931 CL

DAM		Calv.Ease	BW	WW	YW	Milk	HPG	Stay	Maint.En.
Age	3	12	-1.8	24	52	12	10	11	-9.3
Wt	955	Marb +0.10		REA -0.01		Bfat -0.01			
Prog.BW	64	BWt	WWt	WR	ADG	YWt	YR	Scr.	Fr.
WR	97	78	551	97	4.54	1108	103	33	5.5
YR	103								
Wean Pct.	54%								
Cow Eff.	113								

★★★★★ for Low Maintenance, Gainability, Calving Ease.

121 BECKTON CODY U659 K1

1-A 100% # 1259493 Tattoo: BKT8 U659

Birth: 3-31-08

Beckton Cody KH M390
BECKTON CODY K1 P014
 Ref. C-1
 Beckton Rose M126 WR

Beckton Epic KJ J722
BKT PINE MARIE P351 EP
 BKT Pine Marie L002 HR

Beckton Cody K G701
 Beckton Tamara J124 HR
 Beckton Warrior T C371
 Beckton Rose D741 LN
 Beckton Epic K F075
 Beckton Lana F891 JL
 Beckton Herald FV J537
 BKT Pine Marie J931 RN

DAM		Calv.Ease	BW	WW	YW	Milk	HPG	Stay	Maint.En.
Age	4	10	-1.9	24	55	16	8	9	+3.4
Wt	1095	Marb +0.02		REA +0.08		Bfat -0.01			
Prog.BW	75	BWt	WWt	WR	ADG	YWt	YR	Scr.	Fr.
WR	114	75	550	94	4.64	1094	100	36	5.0
YR	111								
Wean Pct.	48%								
Cow Eff.	102								

★★★★★ for Low Maintenance, Gainability, Superior Cow, Calving Ease.

• Bulls •

122 BECKTON EPIC U333 K4
1-A 100% # 1258932 Tattoo: WF8 U333

Birth: 3-17-08
 Beckton Epic KJ J722 < Beckton Epic K F075
 Beckton Epic K4 N795 < Beckton Lana F891 JL
 Ref. E-2 < Beckton Epic D404
 Beckton Sierra J789 EP < Beckton Sierra C157 CL
 Beckton Neptune R2 K065 < Beckton Neptune RR B284
 Beckton Lana C735 TP
BECKTON CHRISTY N213 NP < Beckton Julian 7526G
 Beckton Christy C306 JL < Beckton Christy Z264 NP

DAM		Calv.Ease	BW	WW	YW	Milk	HPG	Stay	Maint.En.
Age	5	14	-5.3	19	54	9	10	11	-7.1
Wt	950	Marb +.18		REA +.01		Bfat +.00			
Prog.BW	61	BWt	WWt	WR	ADG	YWt	YR	Scr.	Fr.
WR	93	62	505	87	3.78	1046	96	36	4.5
YR	95								
Wean Pct.	53%								
Cow Eff.	112								

★★★★★ for Low Maintenance, Marbling, Calving Ease.

125 BKT CLIFFTOP U144 TP
1-A 100% # 1259568 Tattoo: BKT8 U144

Birth: 3-8-08
 Beckton Clifftop T C075 < BJR Topper 5241
 Beckton Barmaid A761 TR
BKT CLIFFTOP TP R288 < Beckton Copper JT G095
 Ref. B-3 < Beckton Christy A111 VQ
 Beckton Julian 7526G
 Bkt Marta 9A13 JL
BECKTON LARKABA R398 JL < Beckton Cody C401
 Beckton Larkaba E042 CD < Beckton Larkaba C317 CL

DAM		Calv.Ease	BW	WW	YW	Milk	HPG	Stay	Maint.En.
Age	3	16	-4.3	18	45	15	10	14	-0.4
Wt	1085	Marb +.10		REA +.32		Bfat +.01			
Prog.BW	52	BWt	WWt	WR	ADG	YWt	YR	Scr.	Fr.
WR	85	69	520	91	4.18	1048	97	34	5.0
YR	97								
Wean Pct.	44%								
Cow Eff.	93								

★★★★★ for Low Maintenance, Gainability, Rib-eye area, Calving Ease, Stayability.

123 BECKTON CODY U721 K1
1-A 100% # 1259047 Tattoo: WF8 U721

Birth: 4-6-08
 Beckton Cody KH M390 < Beckton Cody K G701
 Beckton Tamara J124 HR
BECKTON CODY K1 P014 < Beckton Warrior T C371
 Ref. C-1 < Beckton Rose M126 WR < Beckton Rose D741 LN
 Beckton Epic K4 N795 < Beckton Epic KJ J722
 Beckton Sierra J789 EP
BECKTON CHRISTY R421 EP < Beckton Epic KJ J722
 Beckton Christy N185 EP < Beckton Christy G249 JL

DAM		Calv.Ease	BW	WW	YW	Milk	HPG	Stay	Maint.En.
Age	3	12	-2.4	26	67	14	8	11	+4.7
Wt	1030	Marb +.05		REA +.17		Bfat +.00			
Prog.BW	67	BWt	WWt	WR	ADG	YWt	YR	Scr.	Fr.
WR	95	70	558	98	4.24	1111	103	34	5.0
YR	99								
Wean Pct.	50%								
Cow Eff.	106								

★★★★★ for Gainability, Rib-eye area, Calving Ease.

126 BECKTON NEBULA U139 PJ
1-A 100% # 1259619 Tattoo: BKT8 U139

Birth: 3-6-08
 Beckton Nebula P P707 < Beckton Nebula M045
 Beckton Lana M809 EP
BECKTON NEBULA PJ S543 < Beckton Julio L233
 Ref. N-8 < Beckton Lana P685 JO < Beckton Lana E083 CD
 Beckton Nebula M045
 Beckton Lana M809 EP
BECKTON LYDIA S069 NB < Beckton Warrior CL M686
 Beckton Lydia P583 WR < Beckton Lydia M121 WR

DAM		Calv.Ease	BW	WW	YW	Milk	HPG	Stay	Maint.En.
Age	2	14	-3.1	37	69	13	8	13	-3.4
Wt	740	Marb +.11		REA +.25		Bfat +.01			
Prog.BW	65	BWt	WWt	WR	ADG	YWt	YR	Scr.	Fr.
WR	100	65	534	100	4.03	1034	102	33	5.0
YR	102								
Wean Pct.	64%								
Cow Eff.	135								

★★★★★ for Low Maintenance, Gainability, Marbling, Rib-eye area, High Cow Efficiency, Calving Ease, Stayability. **Selling ½ Interest & Full Possession.**

124 BECKTON JULIAN U154 G5
1-A 100% # 1258768 Tattoo: BKT8 U154

Birth: 3-9-08
 Beckton Julian GJ P535 < Beckton Julian 7526G
 Beckton Mona D086 JL
BECKTON JULIAN G5 S107 < Beckton Dominor ZC M919
 Ref. J-8 < Beckton Minola P826 DM < Beckton Minola M641 WR
 Beckton Dominor Z E401
 Beckton Barmaid J012 CO
BECKTON TAMARA S432 DM < Beckton Justice G302
 Beckton Tamara M878 JC < Beckton Tamara J586 CL

DAM		Calv.Ease	BW	WW	YW	Milk	HPG	Stay	Maint.En.
Age	2	7	+1.4	34	72	12	11	14	-1.3
Wt	890	Marb +.17		REA +.26		Bfat +.01			
Prog.BW	80	BWt	WWt	WR	ADG	YWt	YR	Scr.	Fr.
WR	100	80	534	100	4.29	1063	105	36	5.0
YR	105								
Wean Pct.	53%								
Cow Eff.	112								

★★★★★ for Low Maintenance, Gainability, Marbling, Rib-eye area, Calving Ease, Stayability.

127 BECKTON NEBULA U865
1-A 100% # 1258984 Tattoo: WF8 U865

Birth: 5-6-08
 Beckton Neptune R2 K065 < Beckton Neptune RR B284
 Beckton Lana C735 TP
BECKTON NEBULA M045 < Beckton Julian GG B571
 Ref. N-1 < Beckton Belga K285 JL < Beckton Belga G493 HR
 Beckton Lancer F442 T
 Beckton Belga J293 HR
BECKTON LANA P520 LN < Beckton Warrior T C371
 Beckton Lana L827 WR < Beckton Lana F028 VG

DAM		Calv.Ease	BW	WW	YW	Milk	HPG	Stay	Maint.En.
Age	4	12	-2.1	33	65	10	8	12	-3.3
Wt	1000	Marb +.09		REA +.14		Bfat -.01			
Prog.BW	76	BWt	WWt	WR	ADG	YWt	YR	Scr.	Fr.
WR	104	79	668	109	3.78	1185	107	35	5.5
YR	101								
Wean Pct.	65%								
Cow Eff.	136								

★★★★★ for Low Maintenance, Growth, Rib-eye area, High Cow Efficiency, Calving Ease.

• Bulls •



130 **BECKTON EPIC U024 K6**
1-A 100% # 1258779 Tattoo: BKT8 U024

Birth: 2-19-08
 Beckton Epic KM M115
 Beckton Epic K F075
 Beckton Minerva F495 CH
BECKTON EPIC K6 S569
 Ref. E-5
 Beckton Sierra N703 LM
 Beckton Laramie L044
 Beckton Sierra L887 LN
 Beckton Nomad V 9871
 Beckton Nomad 7496
 Bkt Barmaid 6986 VR
BKT PINE MARIE S501 NM
 BKT Pine Marie J556 EP
 Beckton Epic K F075
 Bkt Pine Marie F030 CL

DAM		Calv.Ease	BW	WW	YW	Milk	HPG	Stay	Maint.En.
Age	2	10	-1.8	33	58	15	7	10	-4.0
Wt	875								
Prog.BW	67								
WR	94								
YR	98								
Wean Pct.	51%								
Cow Eff.	107								
		BWt	WWt	WR	ADG	YWt	YR	Scr.	Fr.
		67	505	94	3.78	996	98	33	5.0

★★★★★ for Low Maintenance, Calving Ease.

128 **BECKTON JORDAN U496**
1-A 100% # 1259513 Tattoo: BKT8 U496

Birth: 3-23-08
 TR Julian LT151
 Beckton Julian GG B571
 MS Geometric 917
TR JULIAN RT561
 Ref. J-13
 TR Dyna HT824
 Buf Crk Dynamics 3820
 Buf Crk Dyna 3082
 Beckton Julio L233
 Beckton Julian G1 J526
 Beckton Rose J725 EP
BECKTON LANA P685 JO
 Beckton Lana E083 CD
 Beckton Cody C401
 Beckton Lana C220 CL

DAM		Calv.Ease	BW	WW	YW	Milk	HPG	Stay	Maint.En.
Age	4	15	-4.8	19	43	13	9	13	+4.3
Wt	1155								
Prog.BW	64								
WR	102								
YR	108								
Wean Pct.	45%								
Cow Eff.	95								
		BWt	WWt	WR	ADG	YWt	YR	Scr.	Fr.
		68	540	93	4.03	1036	95	34	5.0

★★★★★ for Gainability, Calving Ease, Stayability.

131 **BECKTON JULIAN U696 G3**
1-A 100% # 1259430 Tattoo: BKT8 U696

Birth: 4-4-08
 Beckton Julian GG B571
 Beckton Julian 7526G
 Bkt Marta 9A13 JL
BECKTON JULIAN G3 P608
 Ref. J-6
 Bkt Suffeina A828 DM
 Beckton Dominor 9455
 Bkt Suffeina 9493 TT
 Beckton Lancer T A664
 Bkt Suffeina A828 DM
BECKTON LANA M167 LN
 Beckton Lana J384 CD
 Beckton Cody K G701
 Beckton Lana G514 CD

DAM		Calv.Ease	BW	WW	YW	Milk	HPG	Stay	Maint.En.
Age	6	16	-5.6	17	38	12	9	14	-2.6
Wt	1105								
Prog.BW	68								
WR	99								
YR	96								
Wean Pct.	50%								
Cow Eff.	104								
		BWt	WWt	WR	ADG	YWt	YR	Scr.	Fr.
		66	548	94	3.83	1045	96	33	5.0

★★★★★ for Low Maintenance, Marbling, Rib-eye area, Calving Ease, Stayability.

129 **BECKTON LIKABLE U140**
1-A 100% # 1259666 Tattoo: BKT8 U140

Birth: 3-6-08
 Beckton Lancer F442 T
 Beckton Lancer T A664
 Bkt Suffeina A828 DM
BECKTON LIKABLE S633
 Ref. L-4
 Beckton Kit F468 JL
 Beckton Julian GG B571
 Beckton Kit A517 NP
 Beckton Jet L P491
 TR Julian LT151
 Beckton Minerva L278 LN
BECKTON LANA S341 JT
 Beckton Lana P656 JL
 Beckton Julian J153 G
 Beckton Lana J703 CO

DAM		Calv.Ease	BW	WW	YW	Milk	HPG	Stay	Maint.En.
Age	2	13	-3.2	25	49	13	9	15	-1.8
Wt	825								
Prog.BW	66								
WR	99								
YR	100								
Wean Pct.	57%								
Cow Eff.	120								
		BWt	WWt	WR	ADG	YWt	YR	Scr.	Fr.
		66	529	99	2.81	1013	100	37	5.0

★★★★★ for Low Maintenance, Marbling, Rib-eye area, High Cow Efficiency, Calving Ease, Stayability.

132 **BECKTON NEBULA U502 PJ**
1-A 100% # 1259642 Tattoo: BKT8 U502

Birth: 3-23-08
 Beckton Nebula P P707
 Beckton Nebula M045
 Beckton Lana M809 EP
BECKTON NEBULA PJ S543
 Ref. N-8
 Beckton Lana P685 JO
 Beckton Julio L233
 Beckton Lana E083 CD
 Beckton Hawk P248
 Beckton Hustler C2 L079
 Beckton Lana L498 CO
BECKTON BELGA S166 HW
 Beckton Belga P443 JO
 Beckton Julio L233
 Beckton Belga K117 LN

DAM		Calv.Ease	BW	WW	YW	Milk	HPG	Stay	Maint.En.
Age	2	14	-4.7	34	64	15	9	14	-3.1
Wt	855								
Prog.BW	56								
WR	109								
YR	103								
Wean Pct.	61%								
Cow Eff.	129								
		BWt	WWt	WR	ADG	YWt	YR	Scr.	Fr.
		56	585	109	3.72	1049	103	34	5.5

★★★★★ for Low Maintenance, Marbling, Superior Cow, High Cow Efficiency, Calving Ease, Stayability.

• Bulls •

133 **TR LANCER UT830**
1-A 100% # 1240470Tattoo: TR2A8 UT83

Birth: 3-12-08

Beckton Lancer T A664
Beckton Lancer 9380
Beckton Coca 9119 TJ

TR LANCER ST628
Ref. L-5 MS Geometric 928
Algebra I 769
MS Geometric 661

Beckton Julius M213
BKT Julian 7526 G
Beckton Lana H128 HR

TR CEDAR PT474
MS Geometric 023
Algebra I 803
MS Geometric 556

DAM		Calv.Ease	BW	WW	YW	Milk	HPG	Stay	Maint.En.
Age	4	13	-0.8	37	71	13	9	10	+3.5
Wt	NA	Marb +.13		REA +.04		Bfat +.00			
Prog.BW	83	BWt	WWt	WR	ADG	YWt	YR	Scr.	Fr.
WR	105	89	645	105	3.38	1185	107	36	5.5
YR	107								
Wean Pct.NA%	NA								
Cow Eff.	NA								

★★★★★ for Low Maintenance, Growth, Marbling, Superior Cow, Calving Ease.

135 **TR TETON UT834**
1-A 100% # 1240488Tattoo: TR2A8 UT83

Birth: 3-10-08

Loosli Cherokee Teton 316N
BFCK Cherokee Cnyn 4912
Miss LL Divide 703

BUF CRK TETON R088
Ref. B-4 BUF Crk Hall N353
Beckton Lancer F442 T
BUF Crk Hall 6182A

BSF Julian JT911
Beckton Julian G717 GG
TR Lydia G750

TR CEDAR RT516
MS Geometric 027
Algebra I 803
MS Geometric 360

DAM		Calv.Ease	BW	WW	YW	Milk	HPG	Stay	Maint.En.
Age	3	9	.0	33	57	14	9	9.2	-1.5
Wt	NA	Marb +.10		REA +.17		Bfat +.00			
Prog.BW	79	BWt	WWt	WR	ADG	YWt	YR	Scr.	Fr.
WR	102	87	641	104	3.33	1174	106	36	6.0
YR	103								
Wean Pct.NA%	NA								
Cow Eff.	NA								

★★★★★ for Low Maintenance, Rib-eye area, Calving Ease.

134 **TR JUBILATION UT837**
1-A 100% # 1240474Tattoo: TR2A8 UT83

Birth: 2-16-08

Beckton Julian GG B571
BKT Julian 7526 G
BKT Marta 9A13 JL

TR JULIAN LT142
Ref. J-10 TR Lana G760
Beckton Cody V E023
Beckton Lana E828 SC

Beckton Lancer T A664
Beckton Lancer 9380
Beckton Coca 9119 TJ

TR LYDIA PT457
Beckton Lydia E251 CL
Beckton Clipper ER C360
Beckton Lydia C180 CF

DAM		Calv.Ease	BW	WW	YW	Milk	HPG	Stay	Maint.En.
Age	4	16	-2.9	30	54	11	13	12.1	+0.7
Wt	NA	Marb +.07		REA +.00		Bfat +.00			
Prog.BW	75	BWt	WWt	WR	ADG	YWt	YR	Scr.	Fr.
WR	92	78	591	96	3.08	1084	97	37	5.0
YR	97								
Wean Pct.NA%	NA								
Cow Eff.	NA								

★★★★★ for Low Maintenance, Calving Ease.

136 **TR RICARDO UT822**
1-A 100% # 1240465Tattoo: TR2A8 UT82

Birth: 3-4-08

BFCK Cherokee Cnyn 4912
BUF Crk Chf 824-1658
MRM 1431 8611 9109

TR RICARDO RT574
Ref. B-5 TR Dyna LT111
Beckton Julian GG B571
BSF Dyna JT976

Beckton Julian GG B571
BKT Julian 7526 G
BKT Marta 9A13 JL

TR CEDAR NT322
TR Cedar LT115
Beckton Lancer F134 TS
MS Geometric 930

DAM		Calv.Ease	BW	WW	YW	Milk	HPG	Stay	Maint.En.
Age	5	17	-5.1	24	46	16	13	16.2	-3.8
Wt	NA	Marb +.17		REA +.23		Bfat +.01			
Prog.BW	79	BWt	WWt	WR	ADG	YWt	YR	Scr.	Fr.
WR	102	74	612	100	3.07	1103	99	34	5.0
YR	102								
Wean Pct.NA%	NA								
Cow Eff.	NA								

★★★★★ for Low Maintenance, Marbling, Rib-eye area, Calving Ease, Stayability.



137 **TR LANCER UT828**
1-A 100% # 1240473Tattoo: TR2A8 UT82

Birth: 3-29-08

Beckton Lancer T A664
Beckton Lancer 9380
Beckton Coca 9119 TJ

TR LANCER ST628
Ref. L-5 MS Geometric 928
Algebra I 769
MS Geometric 661

Beckton Cody V E023
Beckton Cody C401
Beckton Birdie C353 VG

TR LANA PT460
Beckton Lana E828 SC
Beckton Scamp 8954
Beckton Lana B695 SG

DAM		Calv.Ease	BW	WW	YW	Milk	HPG	Stay	Maint.En.
Age	4	13	-2.0	29	59	14	10	8.8	+4.1
Wt	NA	Marb +.15		REA +.00		Bfat +.00			
Prog.BW	79	BWt	WWt	WR	ADG	YWt	YR	Scr.	Fr.
WR	107	89	664	108	3.31	1194	107	37	6.0
YR	108								
Wean Pct.NA%	NA								
Cow Eff.	NA								

★★★★★ for Marbling, Superior Cow, Calving Ease.

• Bulls •

138 BECKTON EPIC U580 K6

1-A 100% # 1258766 Tattoo: BKT8 U580

Birth: 3-26-08

Beckton Epic KM M115
BECKTON EPIC K6 S569
 Ref. E-5

Beckton Epic K F075
 Beckton Minerva F495 CH

Beckton Sierra N703 LM
 Beckton Laramie L044
 Beckton Sierra L887 LN

Beckton Epic KM M115
BECKTON SHEBA S428 EP
 Beckton Sheba N497 CE

Beckton Epic K F075
 Beckton Minerva F495 CH

Beckton Cruiser K118
 Beckton Sheba K206 JC

DAM		Calv.Ease	BW	WW	YW	Milk	HPG	Stay	Maint.En.
Age	2	10	-1.7	39	81	19	7	11	+2.0
Wt	895								
Prog.BW	65								
WR	112			Marb +.13	REA -.03		Bfat +.01		
YR	112								
Wean Pct.	65%	BWt	WWt	WR	ADG	YWt	YR	Scr.	Fr.
Cow Eff.	136	65	638	112	4.39	1163	112	36	5.0

★★★★★ for Low Maintenance, Growth, Gainability, Marbling, Superior Cow, High Cow Efficiency, Calving Ease.

141 BECKTON EPIC U815 K4

1-A 100% # 1259402 Tattoo: BKT8 U815

Birth: 4-19-08

Beckton Epic KJ J722
BECKTON EPIC K4 N795
 Ref. E-2

Beckton Epic K F075
 Beckton Lana F891 JL

Beckton Sierra J789 EP
 Beckton Epic D404
 Beckton Sierra C157 CL

Beckton Epic D404
BECKTON MINERVA K929 EP
 Beckton Minerva CB69 JL

Beckton Saga KJ B702
 Beckton Kuruba B508 PC

Beckton Julian GN 9A45
 Bkt Minerva 7016 TJ

DAM		Calv.Ease	BW	WW	YW	Milk	HPG	Stay	Maint.En.
Age	8	7	-0.2	28	65	11	9	11	-2.8
Wt	1105								
Prog.BW	81								
WR	104			Marb +.15	REA +.12		Bfat +.02		
YR	104								
Wean Pct.	57%	BWt	WWt	WR	ADG	YWt	YR	Scr.	Fr.
Cow Eff.	119	84	626	102	4.49	1163	105	37	5.0

★★★★★ for Low Maintenance, Gainability, Marbling, Superior Cow, High Cow Efficiency, Calving Ease.

139 BECKTON NEBULA U802 L

1-A 100% # 1259520 Tattoo: BKT8 U802

Birth: 4-17-08

Beckton Nebula M045
BECKTON NEBULA L P093
 Ref. N-3

Beckton Neptune R2 K065
 Beckton Belga K285 JL

Beckton Marta M021 LN
 Beckton Lancer TA K644
 Beckton Marta K254 LN

Beckton Julio L233
BECKTON SUSAN P857 JO
 Beckton Susan G199 CO

Beckton Julian G1 J526
 Beckton Rose J725 EP

Beckton Copper J E616
 Beckton Susan E140 TP

DAM		Calv.Ease	BW	WW	YW	Milk	HPG	Stay	Maint.En.
Age	4	13	-4.7	28	60	13	8	14	-5.2
Wt	980								
Prog.BW	69								
WR	109			Marb +.12	REA +.15		Bfat -.01		
YR	105								
Wean Pct.	66%	BWt	WWt	WR	ADG	YWt	YR	Scr.	Fr.
Cow Eff.	138	66	664	108	4.39	1189	107	36	5.5

★★★★★ for Low Maintenance, Gainability, Marbling, Rib-eye area, Superior Cow, High Cow Efficiency, Calving Ease, Stayability.



140 BECKTON CODY U302 K2

1-A 100% # 1259546 Tattoo: BKT8 U302

Birth: 3-16-08

Beckton Cody KH M390
BECKTON CODY K2 R168
 Ref. C-2

Beckton Cody K G701
 Beckton Tamara J124 HR

Beckton Tamara K249 VG
 Beckton Vegas SV H078
 Beckton Tamara HA38 WR

Beckton Justice G302
BECKTON MINERVA R183 JC
 Beckton Minerva F495 CH

Beckton Julian GG B571
 Bkt Vernice 9733 PC

Beckton Champ R A583
 Beckton Minerva CB69 JL

DAM		Calv.Ease	BW	WW	YW	Milk	HPG	Stay	Maint.En.
Age	3	12	-1.3	34	68	13	8	10	+1.0
Wt	990								
Prog.BW	65								
WR	98			Marb -.02	REA +.18		Bfat +.01		
YR	101								
Wean Pct.	54%	BWt	WWt	WR	ADG	YWt	YR	Scr.	Fr.
Cow Eff.	113	76	573	101	4.69	1131	105	33	5.0

★★★★★ for Low Maintenance, Gainability, Rib-eye area, Calving Ease.

142 BECKTON JULIAN U513 G3

1-A 100% # 1259575 Tattoo: BKT8 U513

Birth: 3-24-08

Beckton Julian GG B571
BECKTON JULIAN G3 P608
 Ref. J-6

Beckton Julian 7526G
 Bkt Marta 9A13 JL

Bkt Suffeina A828 DM
 Beckton Dominor 9455
 Bkt Suffeina 9493 TT

Beckton Loki C M740
BKT PINE MARIE R456 LO
 Bkt Pine Marie F030 CL

Beckton Loki F251
 BKT Larkeisa J051 CK

Beckton Clipper KC D400
 Bkt Pine Marie D319 VG

DAM		Calv.Ease	BW	WW	YW	Milk	HPG	Stay	Maint.En.
Age	3	14	-3.5	26	56	12	12	15	+1.3
Wt	935								
Prog.BW	65								
WR	101			Marb +.06	REA +.18		Bfat +.01		
YR	99								
Wean Pct.	58%	BWt	WWt	WR	ADG	YWt	YR	Scr.	Fr.
Cow Eff.	121	69	577	101	3.88	1116	103	35	5.0

★★★★★ for Low Maintenance, Rib-eye area, High Cow Efficiency, Calving Ease, Stayability.

• Bulls •

143 BECKTON CODY U744 K1

1-A 100% # 1258857 Tattoo: WF8 U744

Birth: 4-9-08

Beckton Cody KH M390
 Beckton Cody K G701
 Beckton Tamara J124 HR

BECKTON CODY K1 P014
 Ref. C-1
 Beckton Rose M126 WR
 Beckton Warrior T C371
 Beckton Rose D741 LN

Beckton Copper JT G095
 Beckton Copper J E616
 Beckton Ruth E549 TP

BECKTON BARMAID J012 CO
 Beckton Barmaid G565 LN
 Beckton Lancer T A664
 Bkt Barmaid 9517 RN

DAM		Calv.Ease	BW	WW	YW	Milk	HPG	Stay	Maint.En.
Age	9	13	-4.3	21	51	19	7	11	-2.6
Wt	990	Marb +15		REA +06		Bfat +00			
Prog.BW	71	BWt	WWt	WR	ADG	YWt	YR	Scr.	Fr.
WR	103	72	628	108	3.88	1132	104	34	5.0
YR	107								
Wean Pct.	63%								
Cow Eff.	134								

★★★★★ for Low Maintenance, Marbling, Superior Cow, High Cow Efficiency, Calving Ease.

146 BECKTON JULIAN U503 GJ

1-A 100% # 1259497 Tattoo: BKT8 U503

Birth: 3-23-08

Beckton Julian 7526G
 Beckton Julian 6592
 Bkt Belga 6746 GS

BECKTON JULIAN GJ P535
 Ref. J-5
 Beckton Mona D086 JL
 Beckton Julian GV Z693
 Beckton Mona 9356 KR

Beckton Lancer F442 T
 Beckton Lancer T A664
 Bkt Suffeina A828 DM

BECKTON COCA P459 LN
 Beckton Coca H192 VG
 Beckton Vegas PK F485
 Beckton Coca F609 VG

DAM		Calv.Ease	BW	WW	YW	Milk	HPG	Stay	Maint.En.
Age	4	14	-3.6	26	52	6	10	14	-3.8
Wt	755	Marb +11		REA +15		Bfat -01			
Prog.BW	67	BWt	WWt	WR	ADG	YWt	YR	Scr.	Fr.
WR	102	68	576	94	4.08	1077	97	34	5.0
YR	105								
Wean Pct.	74%								
Cow Eff.	155								

★★★★★ for Low Maintenance, Gainability, Marbling, Rib-eye area, High Cow Efficiency, Calving Ease, Stayability.

144 BECKTON JET U605 L

1-A 100% # 1259515 Tattoo: BKT8 U605

Birth: 3-28-08

TR Julian LT151
 Beckton Julian GG B571
 MS Geometric 917

BECKTON JET L P491
 Ref. J-4
 Beckton Minerva L278 LN
 Beckton Lancer TS D390
 Beckton Minerva F495 CH

Beckton Loki C M740
 Beckton Loki F251
 BKT Larkeisa J051 CK

BECKTON LANA P700 LO
 Beckton Lana M360 SC
 Beckton Scamp T A825
 Beckton Lana F303 NP

DAM		Calv.Ease	BW	WW	YW	Milk	HPG	Stay	Maint.En.
Age	4	16	-5.4	19	44	16	9	15	+2.9
Wt	940	Marb +16		REA +05		Bfat +00			
Prog.BW	65	BWt	WWt	WR	ADG	YWt	YR	Scr.	Fr.
WR	107	65	570	98	3.98	1094	100	40	5.0
YR	104								
Wean Pct.	59%								
Cow Eff.	123								

★★★★★ for Low Maintenance, Marbling, Superior Cow, High Cow Efficiency, Calving Ease, Stayability.

147 BECKTON JUNO U620

1-A 100% # 1259530 Tattoo: BKT8 U620

Birth: 3-29-08

Beckton Julian G1 J526
 Beckton Julian GG B571
 Beckton Annie F743 LN

BECKTON JUNO N493
 Ref.
 Beckton Serena D760 KR
 Beckton Kaiser FD 9253
 Beckton Serena A420 MB

Beckton Cherokee N N479
 BFCK Cherokee Cryn 4912
 Beckton Dinah C440 NM

BKT PINE MARIE R056 CQ
 BKT Pine Marie N783 CO
 Beckton Copper JT G095
 Bkt Pine Marie D319 VG

DAM		Calv.Ease	BW	WW	YW	Milk	HPG	Stay	Maint.En.
Age	3	13	-3.9	31	49	14	8	13	+1.8
Wt	985	Marb +07		REA +04		Bfat +00			
Prog.BW	63	BWt	WWt	WR	ADG	YWt	YR	Scr.	Fr.
WR	108	69	615	108	3.88	1111	103	33	5.5
YR	103								
Wean Pct.	58%								
Cow Eff.	123								

★★★★★ for Low Maintenance, Superior Cow, High Cow Efficiency, Calving Ease, Stayability.

145 BKT CLIFFTOP U441 T3

1-A 100% # 1259596 Tattoo: BKT8 U441

Birth: 3-21-08

Bkt Clifftop TV G672
 Beckton Clifftop T C075
 Beckton Birdie C353 VG

BECKTON CLIFFTOP T3 N800
 Ref. B-2
 Beckton Lana J384 CD
 Beckton Cody K G701
 Beckton Lana G514 CD

Beckton Neptune R2 K065
 Beckton Nebula M045
 Beckton Belga K285 JL

BECKTON COCA R675 NB
 Beckton Coca H745 CS
 Beckton Caesar M D023
 Beckton Coca E051 CL

DAM		Calv.Ease	BW	WW	YW	Milk	HPG	Stay	Maint.En.
Age	3	12	-1.7	28	55	10	9	12	-2.1
Wt	955	Marb +25		REA +09		Bfat +00			
Prog.BW	63	BWt	WWt	WR	ADG	YWt	YR	Scr.	Fr.
WR	96	72	588	103	4.29	1091	101	35	5.0
YR	93								
Wean Pct.	57%								
Cow Eff.	121								

★★★★★ for Low Maintenance, Gainability, Marbling, High Cow Efficiency, Calving Ease.

148 BECKTON NEBULA U822 N

1-A 100% # 1259566 Tattoo: BKT8 U822

Birth: 4-20-08

Beckton Nebula M045
 Beckton Neptune R2 K065
 Beckton Belga K285 JL

BECKTON NEBULA N R573
 Ref. N-5
 Beckton Lana M621 LN
 Beckton Lancer F442 T
 Beckton Lana H329 HD

Beckton Lancer T7 M089
 Beckton Lancer F442 T
 Beckton Tamara G141 HE

BECKTON VERNICE R374 LN
 Beckton Vernice K798 CD
 Beckton Cody V E023
 Beckton Vernice C047 JL

DAM		Calv.Ease	BW	WW	YW	Milk	HPG	Stay	Maint.En.
Age	3	9	-1.5	36	64	13	11	12	-2.7
Wt	1005	Marb +08		REA +07		Bfat -01			
Prog.BW	84	BWt	WWt	WR	ADG	YWt	YR	Scr.	Fr.
WR	113	82	669	117	3.88	1179	109	35	5.5
YR	107								
Wean Pct.	63%								
Cow Eff.	132								

★★★★★ for Low Maintenance, Growth, Superior Cow, High Cow Efficiency, Calving Ease.

• Bulls •



151 BECKTON NEBULA U001 EN
1-A 100% # 1259157 Tattoo: WF8 U001

Birth: 2-9-08
 Beckton Nebula E P084
 Beckton Nebula M045
 BKT Pine Marie M119 EP
BECKTON NEBULA EN S347
 Ref. N-7 Beckton Eola P530 NB
 Beckton Nebula M045
 Beckton Eola M663 EP
 Beckton Champ R1 H024
 Beckton Nebula M045
 Beckton Champ RH F275
BECKTON LANA S866 CH
 Beckton Lana L519 CH
 Beckton Champ R3 H338
 Beckton Lana H349 HR

DAM		Calv.Ease	BW	WW	YW	Milk	HPG	Stay	Maint.En.
Age	2	14	-5.2	24	50	13	9	14	-5.0
Wt	885								
Prog.BW	63								
WR	95								
YR	99								
Wean Pct.	51%								
Cow Eff.	107								
		BWt	WWt	WR	ADG	YWt	YR	Scr.	Fr.
		63	510	95	4.03	1002	99	34	5.0

★★★★★ for Low Maintenance, Gainability, Rib-eye area, Calving Ease, Stayability.

149 BECKTON EMPEROR U497
1-A 100% # 1259466 Tattoo: BKT8 U497

Birth: 3-23-08
 Beckton Epic K4 N795
BECKTON EMPEROR R100
 Ref. Beckton Tamara N180 JO
 Beckton Epic KJ J722
 Beckton Sierra J789 EP
 Beckton Julio L233
 Beckton Tamara L132 CT
 Beckton Vegas S1 K316
 Beckton Vegas SV H078
 Beckton Eola H073 EP
BECKTON TAMARA N456 VG
 Beckton Tamara F182 CR
 Beckton Colter D392
 Beckton Tamara D558 KR

DAM		Calv.Ease	BW	WW	YW	Milk	HPG	Stay	Maint.En.
Age	5	12	-2.6	23	50	12	8	11	-2.3
Wt	1115								
Prog.BW	68								
WR	97								
YR	99								
Wean Pct.	47%								
Cow Eff.	100								
		BWt	WWt	WR	ADG	YWt	YR	Scr.	Fr.
		70	527	90	4.39	1042	95	36	5.0

★★★★★ for Low Maintenance, Gainability, Marbling, Calving Ease.

152 BECKTON NEBULA U506 P
1-A 100% # 1259000 Tattoo: WF8 U506

Birth: 3-23-08
 Beckton Nebula M045
BECKTON NEBULA P P707
 Ref. N-4 Beckton Lana M809 EP
 Beckton Neptune R2 K065
 Beckton Belga K285 JL
 Beckton Epic K1 K863
 Beckton Lana K253 DM
 Beckton Lancer T5 L095
 Beckton Lancer F442 T
 Beckton Belga J293 HR
BECKTON INDIGO P676 LN
 Beckton Indigo L588 LN
 Beckton Lancer TL G626
 Bkt Indigo 9235 GL

DAM		Calv.Ease	BW	WW	YW	Milk	HPG	Stay	Maint.En.
Age	4	13	-1.9	32	58	14	7	13	-2.7
Wt	1090								
Prog.BW	63								
WR	98								
YR	99								
Wean Pct.	48%								
Cow Eff.	102								
		BWt	WWt	WR	ADG	YWt	YR	Scr.	Fr.
		76	548	94	4.03	1056	97	34	5.5

★★★★★ for Low Maintenance, Gainability, Calving Ease, Stayability.

150 BKT CLIFFTOP U793 T3
1-A 100% # 1258862 Tattoo: WF8 U793

Birth: 4-15-08
 Bkt Clifftop TV G672
BECKTON CLIFFTOP T3 N800
 Ref. B-2 Beckton Lana J384 CD
 Beckton Copper J E616
BECKTON ROSE J565 CO
 Beckton Rose F280 JL
 Beckton Clifftop T C075
 Beckton Birdie C353 VG
 Beckton Cody K G701
 Beckton Lana G514 CD
 Buf Crk Coppertop 3230
 Bkt Larkeisa C894 JV
 Beckton Julian GG B571
 Beckton Rose A624 BF

DAM		Calv.Ease	BW	WW	YW	Milk	HPG	Stay	Maint.En.
Age	9	9	-0.8	24	48	17	7	11	+2.8
Wt	1200								
Prog.BW	75								
WR	108								
YR	105								
Wean Pct.	51%								
Cow Eff.	108								
		BWt	WWt	WR	ADG	YWt	YR	Scr.	Fr.
		79	617	106	4.03	1098	101	36	5.5

★★★★★ for Low Maintenance, Gainability, Marbling, Superior Cow, Calving Ease.

153 BSF CLIFFTOP U238 TP
1-B 94% # 1259237 Tattoo: BSF8 U238

Birth: 3-13-08
 Beckton Clifftop T C075
BKT CLIFFTOP TP R288
 Ref. B-3 Beckton Christy K209 CO
 Beckton Dominor ZC M919
BSF DOMINIQUE P028
 BSF Red M104 LN
 BJR Topper 5241
 Beckton Barmaid A761 TR
 Beckton Copper JT G095
 Beckton Christy A111 VQ
 Beckton Dominor Z E401
 Beckton Barmaid J012 CO
 Beckton Lancer F442 T
 BRU Red HC67

DAM		Calv.Ease	BW	WW	YW	Milk	HPG	Stay	Maint.En.
Age	4	13	-4.5	19	46	16	8	13	-3.2
Wt	995								
Prog.BW	64								
WR	100								
YR	105								
Wean Pct.	57%								
Cow Eff.	120								
		BWt	WWt	WR	ADG	YWt	YR	Scr.	Fr.
		67	589	101	4.18	1101	101	35	5.0

★★★★★ for Low Maintenance, Gainability, Marbling, Rib-eye area, High Cow Efficiency, Calving Ease, Stayability.

• Bulls •

154 BSF NEBULA U553

1-B 99% # 1259281 Tattoo: BSF8 U553

Birth: 3-25-08

Beckton Neptune R2 K065
Beckton Neptune RR B284
Beckton Lana C735 TP

BECKTON NEBULA M045
Ref. N-1
Beckton Belga K285 JL
Beckton Julian GG B571
Beckton Belga G493 HR

Beckton Hustler CN J102
Beckton Hustler C G407
Beckton Belga G355 NP

BSF HUSTELLE R608 HU
Beckton Clipper KH F416
BSF Regus L862 CL
BSF Regus Z776

DAM		Calv.Ease	BW	WW	YW	Milk	HPG	Stay	Maint.En.
Age	3	13	-4.1	34	66	11	11	10	-0.1
Wt	1050								
Prog.BW	68								
WR	101								
YR	104								
Wean Pct.	56%								
Cow Eff.	118								
		Marb			REA			Bfat	
		BWt	WWt	WR	ADG	YWt	YR	Scr.	Fr.
		67	631	111	4.39	1140	106	35	5.0

★★★★★ for Low Maintenance, Growth, Gainability, Rib-eye area, High Cow Efficiency, Calving Ease.

156 BSF CHEROKEE U735 N

1-B 99% # 1259261 Tattoo: BSF8 U735

Birth: 4-8-08

BFCK Cherokee Cnyn 4912
BUF CRK Chief 824-1658
MRM 1431 8611 9109

BECKTON CHEROKEE N N479
Ref. B-1
Beckton Dinah C440 NM
Beckton Nomad K 9949
Beckton Dinah Z610 JL

Beckton Epic K4 N795
Beckton Sierra J789 EP
Beckton Epic KJ J722

BSF ERICA R006 EP
Beckton Epic D404
BSF Erica N231 EP
BSF Regus K132 CO

DAM		Calv.Ease	BW	WW	YW	Milk	HPG	Stay	Maint.En.
Age	3	11	-3.4	30	61	16	10	10	-3.6
Wt	860								
Prog.BW	69								
WR	103								
YR	106								
Wean Pct.	64%								
Cow Eff.	135								
		Marb			REA			Bfat	
		BWt	WWt	WR	ADG	YWt	YR	Scr.	Fr.
		68	592	104	4.54	1145	106	35	5.5

★★★★★ for Low Maintenance, Growth, Gainability, Marbling, Rib-eye area, Superior Cow, High Cow Efficiency, Calving Ease.

155 BSF JULIAN U086 G5

1-B 99% # 1259337 Tattoo: BSF8 U086

Birth: 2-28-08

Beckton Julian GJ P535
Beckton Julian 7526G
Beckton Mona D086 JL

BECKTON JULIAN G5 S107
Ref. J-8
Beckton Minola P826 DM
Beckton Dominor ZC M919
Beckton Minola M641 WR

Beckton Dominor ZC M919
Beckton Dominor Z E401
Beckton Barmaid J012 CO

BSF LAUREL S572 DM
Beckton Lancer T1 H080
BSF Laurel N839 LN
BSF Regus E601

DAM		Calv.Ease	BW	WW	YW	Milk	HPG	Stay	Maint.En.
Age	2	12	-1.7	28	66	13	10	14	-4.2
Wt	790								
Prog.BW	60								
WR	106								
YR	106								
Wean Pct.	64%								
Cow Eff.	135								
		Marb			REA			Bfat	
		BWt	WWt	WR	ADG	YWt	YR	Scr.	Fr.
		60	565	106	4.08	1078	106	35	5.0

★★★★★ for Low Maintenance, Growth, Gainability, Marbling, Superior Cow, High Cow Efficiency, Calving Ease, Stayability.

157 BSF EPIC U568 K6

1-B 99% # 1259331 Tattoo: BSF8 U568

Birth: 3-25-08

Beckton Epic KM M115
Beckton Epic K F075
Beckton Minerva F495 CH

BECKTON EPIC K6 S569
Ref. E-5
Beckton Sierra N703 LM
Beckton Laramie L044
Beckton Sierra L887 LN

Beckton Epic KM M115
Beckton Minerva F495 CH
Beckton Lancer T4 J536

BSF LAUREL S448 EP
BSF Laurel N557 LN
BSF Regus K319 CT

DAM		Calv.Ease	BW	WW	YW	Milk	HPG	Stay	Maint.En.
Age	2	11	-2.5	34	77	19	6	11	-0.5
Wt	750								
Prog.BW	64								
WR	106								
YR	110								
Wean Pct.	68%								
Cow Eff.	143								
		Marb			REA			Bfat	
		BWt	WWt	WR	ADG	YWt	YR	Scr.	Fr.
		64	569	106	4.59	1119	110	33	5.5

★★★★★ for Low Maintenance, Growth, Gainability, Marbling, Rib-eye area, Superior Cow, High Cow Efficiency, Calving Ease.



158 BSF CLIFFTOP U427 TP

1-B 99% # 1259283 Tattoo: BSF8 U427

Birth: 3-21-08

Beckton Clifftop T C075
BJR Topper 5241
Beckton Barmaid A761 TR

BKT CLIFFTOP TP R288
Ref. B-3
Beckton Christy K209 CO
Beckton Copper JT G095
Beckton Christy A111 VQ

Beckton Julian G1 J526
Beckton Julian GG B571
Beckton Annie F743 LN

BSF JULIANNE R624 JL
Beckton Warrior T C371
BSF Regus 9093-2

DAM		Calv.Ease	BW	WW	YW	Milk	HPG	Stay	Maint.En.
Age	3	16	-5.5	19	46	12	9	13	-6.0
Wt	870								
Prog.BW	63								
WR	97								
YR	99								
Wean Pct.	57%								
Cow Eff.	120								
		Marb			REA			Bfat	
		BWt	WWt	WR	ADG	YWt	YR	Scr.	Fr.
		60	534	94	4.44	1083	100	37	5.0

★★★★★ for Low Maintenance, Gainability, Rib-eye area, High Cow Efficiency, Calving Ease, Stayability.

• Bulls •

159 **BSF LANCER U493 T9**
1-B 99% # 1259172 Tattoo: BSF8 U493

Birth: 3-23-08
 Beckton Lancer TA K644
BECKTON LANCER T9 N586
 Ref. L-2
 Beckton Lancer T A664
 Beckton Tamara B570 JL
 Beckton Scamp TR FB22
 Bkt Larkeisa F828 JL
 Beckton Caesar B679
 Beckton Lana B460 MB
 Beckton Julian GK Z623
 BSF Red Z037
 Beckton Caesar M D023
BSF REGUS G340
 BSF Regus CB58

DAM		Calv.Ease	BW	WW	YW	Milk	HPG	Stay	Maint.En.
Age	11	12	-1.7	18	40	11	10	13	-7.9
Wt	1125	Marb +0.08		REA +0.04		Bfat -.01			
Prog.BW	69	BWt	WWt	WR	ADG	YWt	YR	Scr.	Fr.
WR	98	76	506	87	4.44	1063	97	37	5.0
YR	99								
Wean Pct.	43%								
Cow Eff.	91								

★★★★★ for Low Maintenance, Gainability, Calving Ease, Stayability.

162 **BSF EPIC U071 K7**
1-B 99% # 1259325 Tattoo: BSF8 U071

Birth: 2-27-08
 Beckton Epic KJ J722
BECKTON EPIC K7 S583
 Ref.
 Beckton Epic K F075
 Beckton Lana F891 JL
 Beckton Julian GG B571
 Beckton Kit A517 NP
 Bkt Clifftop TV G672
 Beckton Lana J384 CD
 Beckton Champ R1 H024
 BSF Regus H402
 Beckton Clifftop T3 N800
BSF CLIFFTANA S379 CT
 BSF Regus K090 CH

DAM		Calv.Ease	BW	WW	YW	Milk	HPG	Stay	Maint.En.
Age	2	10	+0.5	32	55	13	12	13	-2.0
Wt	890	Marb +0.11		REA +0.13		Bfat -.01			
Prog.BW	72	BWt	WWt	WR	ADG	YWt	YR	Scr.	Fr.
WR	106	72	570	106	3.47	1035	102	36	5.0
YR	102								
Wean Pct.	57%								
Cow Eff.	121								

★★★★★ for Low Maintenance, Marbling, Rib-eye area, High Cow Efficiency, Calving Ease, Stayability.

160 **BSF NEBULA U077 G**
1-B 99% # 1259304 Tattoo: BSF8 U077

Birth: 2-28-08
 Beckton Nebula M045
BECKTON NEBULA G S237
 Ref. N-6
 Beckton Nebula M045
 Beckton Belga K285 JL
 Beckton Julian GG B571
 Beckton Lakme B370 HV
 Beckton Julian G2 M345
 Beckton Encino M723 JL
 Beckton Neptune R2 K065
 BSF Regus K693 CT
 Beckton Juniper P381
BSF NEPTALA S006 JP
 BSF Neptala P236

DAM		Calv.Ease	BW	WW	YW	Milk	HPG	Stay	Maint.En.
Age	2	15	-2.8	30	60	10	12	16	-3.4
Wt	925	Marb +0.13		REA +0.30		Bfat +0.01			
Prog.BW	63	BWt	WWt	WR	ADG	YWt	YR	Scr.	Fr.
WR	105	63	564	105	4.13	1052	104	36	5.0
YR	104								
Wean Pct.	55%								
Cow Eff.	115								

★★★★★ for Low Maintenance, Gainability, Marbling, Rib-eye area, Superior Cow, Calving Ease, Stayability.



161 **BSF WARRIOR U082 C1**
1-B 99% # 1259316 Tattoo: BSF8 U082

Birth: 2-28-08
 Beckton Warrior CL M686
BECKTON WARRIOR C1 S337
 Ref. W-2
 Beckton Warrior CL M686
 Beckton Warrior C C355
 Beckton Christy J223 LN
 Beckton Cody V E023
 Beckton Christy C306 JL
 Beckton Warrior C C355
 Beckton Christy J223 LN
 Beckton Herald F FA20
 BSF Regus F114
 Beckton Christy K101 CD
BSF WARRITA S236 WR
 BSF Regus L114 HR

DAM		Calv.Ease	BW	WW	YW	Milk	HPG	Stay	Maint.En.
Age	2	14	-1.4	36	67	14	12	10	+5.7
Wt	1020	Marb +0.08		REA +0.18		Bfat +0.00			
Prog.BW	64	BWt	WWt	WR	ADG	YWt	YR	Scr.	Fr.
WR	105	64	560	105	3.83	1042	103	36	5.0
YR	103								
Wean Pct.	49%								
Cow Eff.	103								

★★★★★ for Rib-eye area, Superior Cow, Calving Ease.

163 **BSF WARRIOR U110 C1**
1-B 99% # 1259322 Tattoo: BSF8 U110

Birth: 3-3-08
 Beckton Warrior CL M686
BECKTON WARRIOR C1 S337
 Ref. W-2
 Beckton Warrior CL M686
 Beckton Warrior C C355
 Beckton Christy J223 LN
 Beckton Cody V E023
 Beckton Christy C306 JL
 Beckton Justice C K449
 Beckton Ruth K802 HD
 Beckton Lancer TA K644
 BSF Regus H012
 Beckton Christy K101 CD
BSF LAUREL S358 JC
 BSF Laurel N838 LN

DAM		Calv.Ease	BW	WW	YW	Milk	HPG	Stay	Maint.En.
Age	2	14	-1.4	35	66	12	11	11	-2.3
Wt	825	Marb +0.23		REA +0.27		Bfat -.01			
Prog.BW	66	BWt	WWt	WR	ADG	YWt	YR	Scr.	Fr.
WR	105	66	562	105	4.18	1045	103	33	5.5
YR	103								
Wean Pct.	61%								
Cow Eff.	128								

★★★★★ for Low Maintenance, Gainability, Marbling, Rib-eye area, Superior Cow, High Cow Efficiency, Calving Ease. **Selling ½ Interest & Full Possession.**

• Bulls •

164 **BSF JULIAN U811 G3**
1-B 99% # 1259294 Tattoo: BSF8 U811

Birth: 4-18-08

Beckton Julian GG B571
BECKTON JULIAN G3 P608
 Ref. J-6 Bkt Suffeina A828 DM

Beckton Julian 7526G
 Bkt Marta 9A13 JL

Beckton Dominor 9455
 Bkt Suffeina 9493 TT

Beckton Julian G1 J526
BSF JULIANNE R755 JL
 BSF Regus F474

Beckton Julian GG B571
 Beckton Annie F743 LN

Leachman Heavenly 8141
 BSF Regus C551

DAM		Calv.Ease	BW	WW	YW	Milk	HPG	Stay	Maint.En.
Age	3	15	-3.4	29	55	12	10	14	-5.2
Wt	950								
Prog.BW	68								
WR	104								
YR	96								
Wean Pct.	59%								
Cow Eff.	124								

Marb **+14** REA **+11** Bfat **+01**

BWt	WWt	WR	ADG	YWt	YR	Scr.	Fr.
72	598	105	4.39	1139	106	35	5.0

★★★★★ for Low Maintenance, Gainability, Marbling, High Cow Efficiency, Calving Ease, Stayability.

167 **BSF JET U716 L**
1-B 99% # 1259287 Tattoo: BSF8 U716

Birth: 4-5-08

TR Julian LT151
BECKTON JET L P491
 Ref. J-4 Beckton Minerva L278 LN

Beckton Julian GG B571
 MS Geometric 917

Beckton Lancer TS D390
 Beckton Minerva F495 CH

Beckton Neptune R2 K065
BSF NEBULANN R664 NB
 BSF Regus M043 JC

Beckton Nebula M045

Beckton Justice C K449
 BSF Regus K341 JC

DAM		Calv.Ease	BW	WW	YW	Milk	HPG	Stay	Maint.En.
Age	3	18	-5.2	27	53	13	11	15	+1.2
Wt	920								
Prog.BW	57								
WR	109								
YR	102								
Wean Pct.	62%								
Cow Eff.	131								

Marb **+18** REA **+17** Bfat **+00**

BWt	WWt	WR	ADG	YWt	YR	Scr.	Fr.
62	611	107	3.88	1089	101	35	5.0

★★★★★ for Low Maintenance, Marbling, Rib-eye area, High Cow Efficiency, Calving Ease, Stayability.

165 **BSF EPIC U772 KM**
1-B 99% # 1259185 Tattoo: BSF8 U772

Birth: 4-13-08

Beckton Epic K F075
BECKTON EPIC KM M115
 Ref. E-1 Beckton Minerva F495 CH

Beckton Epic D404
 Beckton Belga D483 KR

Beckton Champ R A583
 Beckton Minerva CB69 JL

Beckton Loki F251
BSF REGUS K725 LO
 BSF Regus G182

Beckton Lancer TZ D525
 Bkt Pine Marie D126 JL

Beckton Nomad K 9949
 BSF Regus C791

DAM		Calv.Ease	BW	WW	YW	Milk	HPG	Stay	Maint.En.
Age	8	13	-3.9	30	58	20	3	13	-0.6
Wt	1130								
Prog.BW	72								
WR	110								
YR	107								
Wean Pct.	54%								
Cow Eff.	114								

Marb **+16** REA **-17** Bfat **+02**

BWt	WWt	WR	ADG	YWt	YR	Scr.	Fr.
62	610	103	4.03	1095	97	34	5.0

★★★★★ for Low Maintenance, Gainability, Marbling, Superior Cow, Calving Ease, Stayability.

168 **BECKTON NEBULA U852 E**
1-A 100% # 1259458 Tattoo: BKT8 U852

Birth: 4-29-08

Beckton Nebula M045
BECKTON NEBULA E P084
 Ref. N-2 BKT Pine Marie M119 EP

Beckton Neptune R2 K065
 Beckton Belga K285 JL

Beckton Epic K F075
 Bkt Pine Marie D126 JL

Beckton Warrior TD L493
BECKTON SERENA N088 WR
 Beckton Serena L591 VG

Beckton Warrior T C371
 Bkt Suffeina A828 DM

Beckton Vegas PK F485
 Beckton Serena F248 CZ

DAM		Calv.Ease	BW	WW	YW	Milk	HPG	Stay	Maint.En.
Age	5	15	-4.8	24	56	13	9	13	-5.0
Wt	1075								
Prog.BW	66								
WR	105								
YR	105								
Wean Pct.	63%								
Cow Eff.	132								

Marb **+09** REA **-02** Bfat **-01**

BWt	WWt	WR	ADG	YWt	YR	Scr.	Fr.
67	676	110	4.13	1210	109	38	5.0

★★★★★ for Low Maintenance, Gainability, Superior Cow, High Cow Efficiency, Calving Ease, Stayability.

166 **BSF EPIC U112 K6**
1-B 99% # 1259335 Tattoo: BSF8 U112

Birth: 3-4-08

Beckton Epic KM M115
BECKTON EPIC K6 S569
 Ref. E-5 Beckton Sierra N703 LM

Beckton Epic K F075
 Beckton Minerva F495 CH

Beckton Laramie L044
 Beckton Sierra L887 LN

Beckton Jet L P491
BSF LANETTE S529 JT
 BSF Lanette P754

TR Julian LT151
 Beckton Minerva L278 LN

Beckton Lancer T4 J536
 BSF Regus L619 JL

DAM		Calv.Ease	BW	WW	YW	Milk	HPG	Stay	Maint.En.
Age	2	13	-2.5	30	62	15	7	14	+3.8
Wt	885								
Prog.BW	62								
WR	92								
YR	98								
Wean Pct.	53%								
Cow Eff.	111								

Marb **+10** REA **+09** Bfat **+01**

BWt	WWt	WR	ADG	YWt	YR	Scr.	Fr.
62	525	92	4.03	1017	98	35	5.0

★★★★★ for Low Maintenance, Gainability, Calving Ease, Stayability.

169 **BECKTON WARRIOR U426 T1**
1-A 100% # 1258867 Tattoo: WF8 U426

Birth: 3-21-08

Beckton Warrior T1 H281
BECKTON WARRIOR N645 T1
 Ref. W-1 Beckton Rose H074 EP

Beckton Warrior TC E801
 Beckton Minerva B609 RN

Beckton Epic K F075
 Beckton Rose F791 EM

Beckton Vegas SC H209
BECKTON MINOLA K070 VG
 Beckton Minola H659 CT

Beckton Vegas S F382
 Beckton Lana F268 CT

Beckton Clifftop TC E081
 Beckton Minola Z529 NP

DAM		Calv.Ease	BW	WW	YW	Milk	HPG	Stay	Maint.En.
Age	8	10	-1.7	30	52	10	12	9	-5.4
Wt	1020								
Prog.BW	66								
WR	94								
YR	90								
Wean Pct.	54%								
Cow Eff.	114								

Marb **-01** REA **+14** Bfat **+00**

BWt	WWt	WR	ADG	YWt	YR	Scr.	Fr.
76	554	95	4.29	1056	97	37	5.0

★★★★★ for Low Maintenance, Gainability, Rib-eye area, Calving Ease.

• Bulls •



172 BECKTON JORDAN U618
1-A 100% # 1259071 Tattoo: WF8 U618

Birth: 3-28-08
 TR Julian LT151
 Beckton Julian GG B571
 MS Geometric 917
TR JULIAN RT561
 Ref. J-13 TR Dyna HT824
 Buf Crk Dynamics 3820
 Buf Crk Dyna 3082
 Beckton Neptune R2 K065
 Beckton Belga K285 JL
 Beckton Nebula M045
BECKTON SCARLETT R808 NB
 Andras Scarlett 2029
 Andras Sleep Easy 802
 COF Scarlett

DAM		Calv.Ease	BW	WW	YW	Milk	HPG	Stay	Maint.En.
Age	3	13	-3.0	26	54	12	9	13	-2.9
Wt	800	Marb +0.14		REA +0.17		Bfat -0.01			
Prog.BW	66	BWt	WWt	WR	ADG	YWt	YR	Scr.	Fr.
WR	107	70	591	104	3.93	1113	103	36	5.0
YR	107								
Wean Pct.	69%								
Cow Eff.	145								

★★★★★ for Low Maintenance, Marbling, Rib-eye area, Superior Cow, High Cow Efficiency, Calving Ease, Stayability.

170 BECKTON EPIC U420 KD
1-A 100% # 1259502 Tattoo: BKT8 U420

Birth: 3-20-08
 Beckton Epic K F075
 Beckton Epic D404
 Beckton Belga D483 KR
BECKTON EPIC R350 K
 Ref. E-3 Beckton Larkaba E042 CD
 Beckton Cody C401
 Beckton Larkaba C317 CL
 Beckton Epic K F075
BECKTON LAKME P513 EP
 Beckton Lakme K697 CT
 Beckton Epic D404
 Beckton Belga D483 KR
 Bkt Clifftop TV G672
 Beckton Lakme G128 HD

DAM		Calv.Ease	BW	WW	YW	Milk	HPG	Stay	Maint.En.
Age	4	13	-5.5	19	49	17	11	9	-0.8
Wt	1005	Marb +0.06		REA +0.15		Bfat +0.01			
Prog.BW	66	BWt	WWt	WR	ADG	YWt	YR	Scr.	Fr.
WR	103	62	565	97	4.54	1095	100	36	5.0
YR	103								
Wean Pct.	54%								
Cow Eff.	114								

★★★★★ for Low Maintenance, Gainability, Rib-eye area, Superior Cow, Calving Ease.

173 BECKTON JULIAN U761 G3
1-A 100% # 1258884 Tattoo: WF8 U761

Birth: 4-11-08
 Beckton Julian GG B571
 Beckton Julian 7526G
 Bkt Marta 9A13 JL
BECKTON JULIAN G3 P608
 Ref. J-6 Bkt Suffeina A828 DM
 Beckton Dominor 9455
 Bkt Suffeina 9493 TT
 Beckton Epic KN H110
BECKTON ENCINO L327 EP
 Beckton Encino F103 CR
 Beckton Epic K F075
 Beckton Tara F633 NM
 Beckton Colter D392
 Beckton Encino D308 HB

DAM		Calv.Ease	BW	WW	YW	Milk	HPG	Stay	Maint.En.
Age	7	14	-3.2	21	47	12	11	13	-5.6
Wt	1100	Marb +0.15		REA +0.00		Bfat +0.02			
Prog.BW	71	BWt	WWt	WR	ADG	YWt	YR	Scr.	Fr.
WR	101	75	604	104	3.83	1120	103	36	4.5
YR	105								
Wean Pct.	55%								
Cow Eff.	116								

★★★★★ for Low Maintenance, Marbling, Calving Ease, Stayability.

171 BKT CLIFFTOP U264 T3
1-A 100% # 1258839 Tattoo: WF8 U264

Birth: 3-15-08
 Bkt Clifftop TV G672
 Beckton Clifftop T C075
 Beckton Birdie C353 VG
BECKTON CLIFFTOP T3 N800
 Ref. B-2 Beckton Lana J384 CD
 Beckton Cody K G701
 Beckton Lana G514 CD
 BJR Topper 5241
 Beckton Clifftop T C075
BECKTON LARKABA G311 CT
 Beckton Larkaba D170 JV
 Beckton Barmaid A761 TR
 Beckton Javelin RN Z358
 Beckton Larkaba Z257 ZN

DAM		Calv.Ease	BW	WW	YW	Milk	HPG	Stay	Maint.En.
Age	11	12	-2.1	21	42	12	8	10	-2.1
Wt	1080	Marb +0.21		REA +0.05		Bfat +0.00			
Prog.BW	64	BWt	WWt	WR	ADG	YWt	YR	Scr.	Fr.
WR	97	75	573	93	4.03	1061	96	36	4.5
YR	98								
Wean Pct.	51%								
Cow Eff.	108								

★★★★★ for Low Maintenance, Gainability, Marbling, Calving Ease.

174 BECKTON JET U559 L
1-A 100% # 1259444 Tattoo: BKT8 U559

Birth: 3-25-08
 TR Julian LT151
 Beckton Julian GG B571
 MS Geometric 917
BECKTON JET L P491
 Ref. J-4 Beckton Minerva L278 LN
 Beckton Lancer TS D390
 Beckton Minerva F495 CH
 Beckton Loki F251
BECKTON LANA M793 LO
 Beckton Lana G056 CO
 Beckton Lancer TZ D525
 Bkt Pine Marie D126 JL
 Beckton Copper J E616
 Beckton Lana E014 CO

DAM		Calv.Ease	BW	WW	YW	Milk	HPG	Stay	Maint.En.
Age	6	14	-5.1	20	42	19	7	15	-2.6
Wt	1010	Marb +0.20		REA -0.05		Bfat +0.01			
Prog.BW	68	BWt	WWt	WR	ADG	YWt	YR	Scr.	Fr.
WR	102	72	586	95	4.13	1072	97	36	5.0
YR	101								
Wean Pct.	58%								
Cow Eff.	122								

★★★★★ for Low Maintenance, Gainability, Marbling, High Cow Efficiency, Calving Ease, Stayability.

• Bulls •

175 BECKTON EPIC U841 KM
1-A 100% # 1259445 Tattoo: BKT8 U841

Birth: 4-25-08
 Beckton Epic K F075
 Beckton Epic D404
BECKTON EPIC KM M115
 Ref. E-1 Beckton Minerva F495 CH Beckton Belga D483 KR
 Beckton Champ R A583
 Beckton Minerva CB69 JL
 Beckton Epic K1 K863
 Beckton Epic KN H110
BECKTON LANA M809 EP
 Beckton Lana K253 DM Beckton Rose H019 SC
 Beckton Dominor ZJ H657
 Beckton Lana HA34 DM

DAM		Calv.Ease	BW	WW	YW	Milk	HPG	Stay	Maint.En.
Age	6	10	-2.2	33	66	23	5	9	+2.0
Wt	1130								
Prog.BW	72								
WR	112								
YR	110								
Wean Pct.	57%								
Cow Eff.	121								
		Marb			REA			Bfat	
		BWt	WWt	WR	ADG	YWt	YR	Scr.	Fr.
		77	648	106	3.98	1165	105	38	5.0

★★★★★ for Low Maintenance, Growth, Superior Cow, High Cow Efficiency, Calving Ease.

177 BECKTON COBALT U017
1-A 100% # 1258789 Tattoo: BKT8 U017

Birth: 2-16-08
 Beckton Cody K1 P014
 Beckton Cody KH M390
BECKTON COBALT S029
 Ref. C-3 Beckton Marta P633 JO Beckton Rose M126 WR
 Beckton Julio L233
 Beckton Marta C314 JL
 Beckton Julio L233
 Beckton Julian G1 J526
BECKTON LANA S584 JO
 Beckton Lana M078 LN Beckton Rose J725 EP
 Beckton Lancer F442 T
 Beckton Lana G248 HR

DAM		Calv.Ease	BW	WW	YW	Milk	HPG	Stay	Maint.En.
Age	2	15	-3.9	23	51	12	9	14	-7.6
Wt	805								
Prog.BW	61								
WR	98								
YR	100								
Wean Pct.	57%								
Cow Eff.	121								
		Marb			REA			Bfat	
		BWt	WWt	WR	ADG	YWt	YR	Scr.	Fr.
		61	522	98	4.03	1011	100	34	5.0

★★★★★ for Low Maintenance, Gainability, Rib-eye area, High Cow Efficiency, Calving Ease, Stayability.

176 BECKTON VEGA U178
1-A 100% # 1259048 Tattoo: WF8 U178

Birth: 3-11-08
 Beckton Vegas S1 K316
 Beckton Vegas SV H078
BECKTON VEGA P079
 Ref. V-1 Beckton Lydia H159 JL Beckton Eola H073 EP
 Beckton Julian GG B571
 Beckton Lydia D386 CL
 Beckton Cody KH M390
 Beckton Tamara J124 HR
BECKTON CHRISTY R434 CD
 Beckton Christy M362 WR Beckton Warrior T C371
 Beckton Christy C306 JL

DAM		Calv.Ease	BW	WW	YW	Milk	HPG	Stay	Maint.En.
Age	3	15	-4.4	22	48	14	11	11	+0.3
Wt	835								
Prog.BW	63								
WR	94								
YR	98								
Wean Pct.	63%								
Cow Eff.	134								
		Marb			REA			Bfat	
		BWt	WWt	WR	ADG	YWt	YR	Scr.	Fr.
		63	569	100	3.98	1061	98	33	5.0

★★★★★ for Low Maintenance, High Cow Efficiency, Calving Ease.

178 BECKTON NEBULA U509 L
1-A 100% # 1259434 Tattoo: BKT8 U509

Birth: 3-24-08
 Beckton Nebula M045
 Beckton Neptune R2 K065
BECKTON NEBULA L P093
 Ref. N-3 Beckton Marta M021 LN Beckton Belga K285 JL
 Beckton Lancer TA K644
 Beckton Marta K254 LN
 Beckton Epic K1 K863
 Beckton Rose H019 SC
BECKTON INDIGO M299 EP
 Beckton Indigo K486 EP Beckton Epic K F075
 Beckton Indigo C106 LN

DAM		Calv.Ease	BW	WW	YW	Milk	HPG	Stay	Maint.En.
Age	6	15	-5.0	24	51	8	9	12	-8.0
Wt	1020								
Prog.BW	65								
WR	96								
YR	97								
Wean Pct.	52%								
Cow Eff.	110								
		Marb			REA			Bfat	
		BWt	WWt	WR	ADG	YWt	YR	Scr.	Fr.
		64	531	91	3.98	1046	96	36	5.0

★★★★★ for Low Maintenance, Rib-eye area, Calving Ease.



179 BECKTON COBALT U059
1-A 100% # 1259633 Tattoo: BKT8 U059

Birth: 2-26-08
 Beckton Cody K1 P014
 Beckton Cody KH M390
BECKTON COBALT S029
 Ref. C-3 Beckton Marta P633 JO Beckton Rose M126 WR
 Beckton Julio L233
 Beckton Marta C314 JL
 Beckton Cody K1 P014
 Beckton Cody KH M390
BECKTON COCA S115 CD
 Beckton Coca P762 WR Beckton Rose M126 WR
 Beckton Warrior T1 H281
 Beckton Coca K658 CO

DAM		Calv.Ease	BW	WW	YW	Milk	HPG	Stay	Maint.En.
Age	2	15	-4.5	24	56	15	9	11	-5.1
Wt	815								
Prog.BW	57								
WR	104								
YR	103								
Wean Pct.	61%								
Cow Eff.	129								
		Marb			REA			Bfat	
		BWt	WWt	WR	ADG	YWt	YR	Scr.	Fr.
		57	558	104	4.24	1043	103	34	4.5

★★★★★ for Low Maintenance, Gainability, Rib-eye area, Superior Cow, High Cow Efficiency, Calving Ease.

• Bulls •

180 BECKTON CLIFFTOP U525 T

1-A 100% # 1259586 Tattoo: BKT8 U525

Birth: 3-24-08

↗ BJR Topper 5241 ↘ Bieber Topper 2476
 ↘ BJR Lakina 002-0142
BECKTON CLIFFTOP T C075
 Ref. ↘ Beckton Barmaid A761 TR ↘ Beckton Tartan 8148
 ↘ Bkt Barmaid 8925 KR
 ↗ Beckton Heritage N013 ↘ Beckton Hustler C2 L079
BECKTON MINERVA R562 HT
 ↘ Beckton Minerva N274 VG ↘ Beckton Lana L007 JL
 ↘ Beckton Vegas S1 K316
 ↘ Beckton Minerva E932 JL

DAM		Calv.Ease	BW	WW	YW	Milk	HPG	Stay	Maint.En.
Age	3	14	-5.2	24	50	15	8	13	+1.8
Wt	1060	Marb +.10		REA +.14		Bfat -.01			
Prog.BW	62	BWt	WWt	WR	ADG	YWt	YR	Scr.	Fr.
WR	102	62	579	102	3.42	1078	100	36	5.0
YR	100								
Wean Pct.	51%								
Cow Eff.	107								

★★★★★ for Low Maintenance, Rib-eye area, Calving Ease, Stayability.

183 BECKTON LOKI U507 CL

1-A 100% # 1259135 Tattoo: WF8 U507

Birth: 3-24-08

↗ Beckton Loki C M740 ↘ Beckton Loki F251
 ↘ BKT Larkeisa J051 CK
BECKTON LOKI CL S284
 Ref. L-3 ↘ Beckton Lakme J460 LT ↘ Beckton Latigo G714
 ↘ Beckton Lakme G128 HD
 ↗ Beckton Clifftop T3 N800 ↘ Bkt Clifftop TV G672
BKT SCARLETT S650 CT
 ↘ Andras Scarlett 2029 ↘ Beckton Lana J384 CD
 ↘ Andras Sleep Easy 802
 ↘ COF Scarlett

DAM		Calv.Ease	BW	WW	YW	Milk	HPG	Stay	Maint.En.
Age	2	7	+0.9	34	64	15	9	10	-1.9
Wt	820	Marb +.14		REA +.16		Bfat +.00			
Prog.BW	84	BWt	WWt	WR	ADG	YWt	YR	Scr.	Fr.
WR	106	84	566	106	3.83	1067	105	37	5.0
YR	105								
Wean Pct.	62%								
Cow Eff.	130								

★★★★★ for Low Maintenance, Growth, Marbling, Rib-eye area, Superior Cow, High Cow Efficiency, Calving Ease.

181 BECKTON CHEROKEE U783 N

1-A 100% # 1258837 Tattoo: WF8 U783

Birth: 4-14-08

↗ BFCK Cherokee Cnyn 4912 ↘ BUF CRK Chief 824-1658
 ↘ MRM 1431 8611 9109
BECKTON CHEROKEE N N479
 Ref. B-1 ↘ Beckton Dinah C440 NM ↘ Beckton Nomad K 9949
 ↘ Beckton Dinah Z610 JL
 ↗ Beckton Julian GG B571 ↘ Beckton Julian 7526G
BECKTON LANA F792 JL
 ↘ Beckton Lana A679 SC ↘ Bkt Marta 9A13 JL
 ↘ Beckton Scamp 8954
 ↘ Beckton Lana 8687 GS

DAM		Calv.Ease	BW	WW	YW	Milk	HPG	Stay	Maint.En.
Age	12	14	-2.0	34	53	12	12	14	-5.0
Wt	1095	Marb +.06		REA +.13		Bfat +.02			
Prog.BW	73	BWt	WWt	WR	ADG	YWt	YR	Scr.	Fr.
WR	98	76	611	105	4.24	1118	102	34	5.0
YR	99								
Wean Pct.	54%								
Cow Eff.	114								

★★★★★ for Low Maintenance, Gainability, Rib-eye area, Calving Ease, Stayability.



182 BECKTON HERITAGE U390

1-A 100% # 1258936 Tattoo: WF8 U390

Birth: 3-19-08

↗ Beckton Hustler C2 L079 ↘ Beckton Hustler CN J102
 ↘ Beckton Barmaid J012 CO
BECKTON HERITAGE N013
 Ref. H-1 ↘ Beckton Lana L007 JL ↘ Beckton Julian G1 J526
 ↘ Beckton Lana J790 EP
 ↗ Beckton Neptune R2 K065 ↘ Beckton Neptune RR B284
BECKTON ANGEL N321 NP
 ↘ Beckton Angel F738 LN ↘ Beckton Lana C735 TP
 ↘ Beckton Lancer TZ D525
 ↘ Beckton Angel D302 RN

DAM		Calv.Ease	BW	WW	YW	Milk	HPG	Stay	Maint.En.
Age	5	13	-4.9	23	39	14	8	11	-3.5
Wt	1020	Marb +.13		REA +.04		Bfat -.01			
Prog.BW	70	BWt	WWt	WR	ADG	YWt	YR	Scr.	Fr.
WR	102	70	528	91	4.13	993	91	35	5.0
YR	99								
Wean Pct.	52%								
Cow Eff.	109								

★★★★★ for Low Maintenance, Gainability, Marbling, Calving Ease.

184 BECKTON LIKABLE U366

1-A 100% # 1259653 Tattoo: BKT8 U366

Birth: 3-18-08

↗ Beckton Lancer F442 T ↘ Beckton Lancer T A664
 ↘ Bkt Suffeina A828 DM
BECKTON LIKABLE S633
 Ref. L-4 ↘ Beckton Kit F468 JL ↘ Beckton Julian GG B571
 ↘ Beckton Kit A517 NP
 ↗ Beckton Warrior T1 H281 ↘ Beckton Warrior TC E801
BECKTON MINERVA S247 WR
 ↘ Beckton Minerva L344 CH ↘ Beckton Minerva B609 RN
 ↘ Beckton Champ R3 H338
 ↘ Beckton Minerva E932 JL

DAM		Calv.Ease	BW	WW	YW	Milk	HPG	Stay	Maint.En.
Age	2	11	-1.4	28	57	10	9	12	-5.4
Wt	820	Marb +.10		REA +.24		Bfat +.00			
Prog.BW	74	BWt	WWt	WR	ADG	YWt	YR	Scr.	Fr.
WR	99	74	561	99	4.08	1064	103	32	5.0
YR	103								
Wean Pct.	61%								
Cow Eff.	129								

★★★★★ for Low Maintenance, Gainability, Rib-eye area, High Cow Efficiency, Calving Ease.

• Bulls •

185 BECKTON CODY U682 K1

1-A 100% # 1258969 Tattoo: WF8 U682

Birth: 4-2-08

Beckton Cody KH M390
BECKTON CODY K1 P014
 Ref. C-1

Beckton Cody K G701
 Beckton Tamara J124 HR

Beckton Warrior T C371
 Beckton Rose D741 LN

Beckton Julio L233
BECKTON BAYBERRY P273 JO
 Bkt Bayberry LC31 SC

Beckton Julian G1 J526
 Beckton Rose J725 EP

Beckton Scamp TR FB22
 Bkt Bayberry D736 GL

DAM		Calv.Ease	BW	WW	YW	Milk	HPG	Stay	Maint.En.
Age	4	13	-2.1	24	53	14	9	11	-0.6
Wt	1050								
Prog.BW	64								
WR	94		Marb		REA		Bfat		
YR	96								
Wean Pct.	51%								
Cow Eff.	107								

★★★★★ for Low Maintenance, Gainability, Calving Ease.

188 BECKTON JET U634 L

1-A 100% # 1259453 Tattoo: BKT8 U634

Birth: 3-29-08

TR Julian LT151
BECKTON JET L P491
 Ref. J-4

Beckton Julian GG B571
 MS Geometric 917

Beckton Lancer TS D390
 Beckton Minerva F495 CH

Beckton Lancer T5 L095
BECKTON LANA N041 LN
 Beckton Lana L923 CD

Beckton Lancer F442 T
 Beckton Belga J293 HR

Beckton Cody K G701
 Beckton Lana D232 HV

DAM		Calv.Ease	BW	WW	YW	Milk	HPG	Stay	Maint.En.
Age	5	17	-6.1	16	37	17	7	14	+5.5
Wt	1060								
Prog.BW	65								
WR	105		Marb		REA		Bfat		
YR	104								
Wean Pct.	50%								
Cow Eff.	106								

★★★★★ for Gainability, Rib-eye area, Superior Cow, Calving Ease, Stayability.

186 BECKTON COBALT U037

1-A 100% # 1258805 Tattoo: BKT8 U037

Birth: 2-21-08

Beckton Cody K1 P014
BECKTON COBALT S029
 Ref. C-3

Beckton Rose M126 WR

Beckton Julio L233
 Beckton Marta C314 JL

Beckton Julio L233
BECKTON VERNICE S713 JO
 Beckton Vernice M286 LN

Beckton Julian G1 J526
 Beckton Rose J725 EP

Beckton Lancer TL G626
 Beckton Vernice D121 VG

DAM		Calv.Ease	BW	WW	YW	Milk	HPG	Stay	Maint.En.
Age	2	14	-3.4	23	53	12	8	14	-3.9
Wt	880								
Prog.BW	63								
WR	90		Marb		REA		Bfat		
YR	95								
Wean Pct.	52%								
Cow Eff.	108								

★★★★★ for Low Maintenance, Rib-eye area, Calving Ease, Stayability.

189 BECKTON JUSTICE U452 C1

1-A 100% # 1258855 Tattoo: WF8 U452

Birth: 3-21-08

Beckton Justice CH M056
BECKTON JUSTICE C1 R483
 Ref. J-7

Beckton Ruth K802 HD

Beckton Herald F FA20
 Beckton Tamara F183 CT

Beckton Champ RK E121
BECKTON LANA H725 CH
 Beckton Lana E937 NM

Beckton Champ R A583
 Beckton Christy Z453 KR

Beckton Nomad K 9949
 Beckton Lana 9628 RV

DAM		Calv.Ease	BW	WW	YW	Milk	HPG	Stay	Maint.En.
Age	10	13	-3.7	20	45	16	9	10	+0.6
Wt	1160								
Prog.BW	74								
WR	104		Marb		REA		Bfat		
YR	105								
Wean Pct.	44%								
Cow Eff.	93								

★★★★★ for Low Maintenance, Superior Cow, Calving Ease.

187 BECKTON NEBULA U745 E

2 100% # 1259054 Tattoo: WF8 U745

Birth: 4-9-08

Beckton Nebula M045
BECKTON NEBULA E P084
 Ref. N-2

Beckton Neptune R2 K065
 Beckton Belga K285 JL

Beckton Epic K F075
 Bkt Pine Marie D126 JL

Beckton Heritage N013
BECKTON INDIGO R528 HT
 Beckton Indigo N173 VG

Beckton Hustler C2 L079
 Beckton Lana L007 JL

Beckton Vegas S1 K316
 Beckton Indigo F376 CT

DAM		Calv.Ease	BW	WW	YW	Milk	HPG	Stay	Maint.En.
Age	3	13	-4.5	27	55	12	10	15	-5.1
Wt	900								
Prog.BW	68								
WR	98		Marb		REA		Bfat		
YR	101								
Wean Pct.	62%								
Cow Eff.	130								

★★★★★ for Low Maintenance, Marbling, High Cow Efficiency, Calving Ease, Stayability.

190 BECKTON JET U779 L

1-A 100% # 1259037 Tattoo: WF8 U779

Birth: 4-13-08

TR Julian LT151
BECKTON JET L P491
 Ref. J-4

Beckton Julian GG B571
 MS Geometric 917

Beckton Lancer TS D390
 Beckton Minerva F495 CH

Beckton Epic K F075
BKT SUFFEINA R312 EP
 Bkt Suffeina A828 DM

Beckton Epic D404
 Beckton Belga D483 KR

Beckton Dominor 9455
 Bkt Suffeina 9493 TT

DAM		Calv.Ease	BW	WW	YW	Milk	HPG	Stay	Maint.En.
Age	3	12	-4.5	19	47	16	9	14	-0.8
Wt	955								
Prog.BW	71								
WR	103		Marb		REA		Bfat		
YR	103								
Wean Pct.	54%								
Cow Eff.	115								

★★★★★ for Low Maintenance, Gainability, Marbling, Rib-eye area, Superior Cow, Calving Ease, Stayability.

• Bulls •



193 BECKTON JULIAN U799 G3
1-A 100% # 1259545 Tattoo: BKT8 U799

Birth: 4-16-08
 Beckton Julian GG B571
 Beckton Julian 7526G
 Bkt Marta 9A13 JL
BECKTON JULIAN G3 P608
 Ref. J-6 Bkt Suffeina A828 DM
 Beckton Dominor 9455
 Bkt Suffeina 9493 TT
 Beckton Epic KM M115
 Beckton Epic K F075
BECKTON SERENA R180 EP
 Beckton Serena F248 CZ
 Beckton Minerva F495 CH
 Beckton Cozad D789
 Beckton Serena D128 NP

DAM		Calv.Ease	BW	WW	YW	Milk	HPG	Stay	Maint.En.
Age	3	15	-4.6	24	49	16	9	14	-1.3
Wt	995	Marb +0.11		REA +0.01		Bfat +0.01			
Prog.BW	64	BWt	WWt	WR	ADG	YWt	YR	Scr.	Fr.
WR	109	65	626	110	3.42	1080	100	32	5.0
YR	103								
Wean Pct.	59%								
Cow Eff.	124								

★★★★★ for Low Maintenance, Marbling, Superior Cow, High Cow Efficiency, Calving Ease, Stayability.

191 BECKTON NEBULA U678 E
1-A 100% # 1258979 Tattoo: WF8 U678

Birth: 4-2-08
 Beckton Nebula M045
 Beckton Neptune R2 K065
 Beckton Belga K285 JL
BECKTON NEBULA E P084
 Ref. N-2 BKT Pine Marie M119 EP
 Beckton Epic K F075
 Bkt Pine Marie D126 JL
 Beckton Nebula M045
 Beckton Neptune R2 K065
BECKTON MINOLA P448 NB
 Beckton Minola M693 NP
 Beckton Belga K285 JL
 Beckton Neptune R2 K065
 Beckton Minola K288 BJ

DAM		Calv.Ease	BW	WW	YW	Milk	HPG	Stay	Maint.En.
Age	4	17	-6.2	18	44	8	11	16	-7.0
Wt	990	Marb +0.06		REA +0.09		Bfat +0.01			
Prog.BW	55	BWt	WWt	WR	ADG	YWt	YR	Scr.	Fr.
WR	93	66	549	89	3.78	1034	93	33	4.5
YR	96								
Wean Pct.	54%								
Cow Eff.	113								

★★★★★ for Low Maintenance, Calving Ease, Stayability.

194 BECKTON CHEROKEE U536 N
1-A 100% # 1259577 Tattoo: BKT8 U536

Birth: 3-24-08
 BFCK Cherokee Cynr 4912
 BUF CRK Chief 824-1658
 MRM 1431 8611 9109
BECKTON CHEROKEE N N479
 Ref. B-1 Beckton Dinah C440 NM
 Beckton Nomad K 9949
 Beckton Dinah Z610 JL
 Beckton Justice G302
 Beckton Julian GG B571
BECKTON VERNICE R460 JC
 Beckton Vernice C047 JL
 Bkt Vernice 9733 PC
 Beckton Julian SJ A470
 Beckton Vernice A140 JU

DAM		Calv.Ease	BW	WW	YW	Milk	HPG	Stay	Maint.En.
Age	3	13	-4.0	27	44	10	12	11	-3.5
Wt	1020	Marb +0.06		REA +0.08		Bfat +0.02			
Prog.BW	68	BWt	WWt	WR	ADG	YWt	YR	Scr.	Fr.
WR	91	69	523	92	3.78	1001	93	33	5.0
YR	94								
Wean Pct.	47%								
Cow Eff.	100								

★★★★★ for Low Maintenance, Calving Ease.

192 BKT CLIFFTOP U759 T3
1-A 100% # 1259536 Tattoo: BKT8 U759

Birth: 4-10-08
 Bkt Clifftop TV G672
 Beckton Clifftop T C075
 Beckton Birdie C353 VG
BECKTON CLIFFTOP T3 N800
 Ref. B-2 Beckton Lana J384 CD
 Beckton Cody K G701
 Beckton Lana G514 CD
 Beckton Epic KM M115
 Beckton Epic K F075
BECKTON LANA R131 EP
 Beckton Lana J211 CL
 Beckton Minerva F495 CH
 Beckton Clipper KR C290
 Beckton Lana D824 NP

DAM		Calv.Ease	BW	WW	YW	Milk	HPG	Stay	Maint.En.
Age	3	11	-2.5	26	52	13	7	8	-0.5
Wt	910	Marb +0.22		REA -0.07		Bfat +0.01			
Prog.BW	67	BWt	WWt	WR	ADG	YWt	YR	Scr.	Fr.
WR	105	68	604	106	3.62	1073	99	36	5.0
YR	100								
Wean Pct.	62%								
Cow Eff.	131								

★★★★★ for Low Maintenance, Marbling, High Cow Efficiency, Calving Ease.

195 BECKTON NEBULA U803 N
1-A 100% # 1259025 Tattoo: WF8 U803

Birth: 4-17-08
 Beckton Nebula M045
 Beckton Neptune R2 K065
 Beckton Belga K285 JL
BECKTON NEBULA N R573
 Ref. N-5 Beckton Lana M621 LN
 Beckton Lancer F442 T
 Beckton Lana H329 HD
 Beckton Cherokee N N479
 BFCK Cherokee Cynr 4912
BECKTON MONA R166 CQ
 Beckton Mona N342 HU
 Beckton Dinah C440 NM
 Beckton Hustler C2 L079
 Beckton Mona L890 CO

DAM		Calv.Ease	BW	WW	YW	Milk	HPG	Stay	Maint.En.
Age	3	11	-3.1	31	53	14	10	13	+0.3
Wt	1075	Marb +0.20		REA +0.03		Bfat -0.01			
Prog.BW	71	BWt	WWt	WR	ADG	YWt	YR	Scr.	Fr.
WR	104	71	589	103	3.83	1064	99	36	5.0
YR	101								
Wean Pct.	51%								
Cow Eff.	108								

★★★★★ for Low Maintenance, Marbling, Calving Ease, Stayability.

• Bulls •

196 BECKTON EPITOMY U825

1-A 100% # 1258786 Tattoo: BKT8 U825

Birth: 4-21-08

Beckton Epic K4 N795
 Beckton Epic KJ J722
 Beckton Sierra J789 EP

BECKTON EPITOMY S250
 Ref. Beckton Tara M635 JL
 Beckton Julian GG B571
 Beckton Tara J266 HR

Beckton Julian G3 P608
 Beckton Encino P733 HU
 Beckton Julian GG B571
 Bkt Suffeina A828 DM
 Beckton Hustler CN J102
 Beckton Encino H115 HD

DAM		Calv.Ease	BW	WW	YW	Milk	HPG	Stay	Maint.En.
Age	2	13	-2.3	30	66	13	12	16	+1.5
Wt	835	Marb +.12		REA +.21		Bfat +.00			
Prog.BW	66	BWt	WWt	WR	ADG	YWt	YR	Scr.	Fr.
WR	101	66	572	101	3.32	1046	101	33	5.5
YR	101								
Wean Pct.	61%								
Cow Eff.	129								

★★★★★ for Low Maintenance, Marbling, Rib-eye area, High Cow Efficiency, Calving Ease, Stayability.

198 BECKTON JORDAN U677

1-A 100% # 1259367 Tattoo: BKT8 U677

Birth: 4-2-08

TR Julian LT151
 Beckton Julian GG B571
 MS Geometric 917

TR JULIAN RT561
 Ref. J-13 TR Dyna HT824
 Buf Crk Dynamics 3820
 Buf Crk Dyna 3082

Beckton Copper J E616
 Beckton Serena E159 CL
 Beckton Lanker 3230
 Bkt Larkeisa C894 JV
 Beckton Clipper J 9956
 Bkt Serena 9864 MB

DAM		Calv.Ease	BW	WW	YW	Milk	HPG	Stay	Maint.En.
Age	11	15	-3.9	20	39	13	7	12	-0.6
Wt	1020	Marb +.04		REA +.04		Bfat -.01			
Prog.BW	65	BWt	WWt	WR	ADG	YWt	YR	Scr.	Fr.
WR	98	64	526	90	3.62	981	90	33	5.0
YR	99								
Wean Pct.	50%								
Cow Eff.	104								

★★★★★ for Low Maintenance, Calving Ease.

197 BKT CLIFFTOP U830 T3

1-A 100% # 1258952 Tattoo: WF8 U830

Birth: 4-22-08

Bkt Clifftop TV G672
 Beckton Clifftop T C075
 Beckton Birdie C353 VG

BECKTON CLIFFTOP T3 N800
 Ref. B-2 Beckton Lana J384 CD
 Beckton Cody K G701
 Beckton Lana G514 CD

Beckton Julian G1 J526
 Beckton Minola J091 JL
 Beckton Julian GG B571
 Beckton Annie F743 LN
 Beckton Julian GG B571
 Beckton Minola D330 JL

DAM		Calv.Ease	BW	WW	YW	Milk	HPG	Stay	Maint.En.
Age	5	15	-3.2	27	55	11	10	14	+0.6
Wt	1175	Marb +.18		REA +.10		Bfat +.00			
Prog.BW	67	BWt	WWt	WR	ADG	YWt	YR	Scr.	Fr.
WR	106	69	586	101	3.78	1049	96	37	5.0
YR	103								
Wean Pct.	50%								
Cow Eff.	105								

★★★★★ for Low Maintenance, Marbling, Superior Cow, Calving Ease, Stayability.

199 TR JULIAN UT804

1-A 100% # 1240516 Tattoo: TR2A8 UT80

Birth: 2-24-08

Beckton Julian GG B571
 BKT Julian 7526 G
 BKT Marta 9A13 JL

TR JULIAN LT151
 Ref. J-11 MS Geometric 917
 BJR Yo 121
 MS Geometric

Beckton Cody V E023
 BSF Sierra KT049
 Beckton Cody C401
 Beckton Birdie C353 VG
 Beckton Julian GG B571
 TR Sierra G715

DAM		Calv.Ease	BW	WW	YW	Milk	HPG	Stay	Maint.En.
Age	4	14	-3.0	25	53	13	14	14.8	+2.2
Wt	NA	Marb +.19		REA +.22		Bfat +.01			
Prog.BW	80	BWt	WWt	WR	ADG	YWt	YR	Scr.	Fr.
WR	101	78	578	NA	2.89	1041	NA	37	5.0
YR	99								
Wean Pct.	NA%								
Cow Eff.	NA								

★★★★★ for Low Maintenance, Marbling, Rib-eye area, Calving Ease, Stayability.



200 TR TETON UT838

1-A 100% # 1240491 Tattoo: TR2A8 UT83

Birth: 2-18-08

Loosli Cherokee Teton 316N
 BFCK Cherokee Cnyn 4912
 Miss LL Divide 703

BUF CRK TETON R088
 Ref. B-4 BUF Crk Hall N353
 Beckton Lancer F442 T
 BUF Crk Hall 6182A

BKT Julian 7526 G
 Beckton Coca L388 CK
 Beckton Julian 6592
 BKT Belga 6746 GS
 Beckton Colt G552
 Beckton Coca G488 WR

DAM		Calv.Ease	BW	WW	YW	Milk	HPG	Stay	Maint.En.
Age	3	13	-4.2	24	47	12	12	11.8	-0.6
Wt	NA	Marb +.07		REA +.06		Bfat +.01			
Prog.BW	64	BWt	WWt	WR	ADG	YWt	YR	Scr.	Fr.
WR	101	64	575	94	3.16	1080	97	33	5.0
YR	103								
Wean Pct.	NA%								
Cow Eff.	NA								

★★★★★ for Low Maintenance, Calving Ease.

• Bulls •

201 **TR TETON UT840**
1-A 100% # 1240490Tattoo: TR2A8 UT84

Birth: 3-7-08
 ↙ Loosli Cherokee Teton 316N ↘ BFCK Cherokee Cnyn 4912
 Miss LL Divide 703
BUF CRK TETON R088
 Ref. B-4 ↙ BUF Crk Hall N353 ↘ Beckton Lancer F442 T
 BUF Crk Hall 6182A
 ↙ Mushrush LT N020 ↘ TR Julian LT142
 Mushrush Lana 1061
TR KURUBA RT544
 ↙ TR Kuruba NT320 ↘ TR Hobo LT144
 Beckton Kuruba E688 BR

DAM		Calv.Ease	BW	WW	YW	Milk	HPG	Stay	Maint.En.
Age	3	10	-1.5	30	52	15	10	11.8	.0
Wt	NA	Marb +16		REA +09		Bfat +00			
Prog.BW	80	BWt	WWt	WR	ADG	YWt	YR	Scr.	Fr.
WR	100	80	615	100	3.12	1114	100	33	5.0
YR	100								
Wean Pct.NA%	NA								
Cow Eff.	NA								

★★★★★ for Low Maintenance, Marbling, Calving Ease.

204 **TR LANCER UT827**
1-A 100% # 1240482Tattoo: TR2A8 UT82

Birth: 2-21-08
 ↙ Beckton Lancer T A664 ↘ Beckton Lancer 9380
 Beckton Coca 9119 TJ
TR LANCER ST628
 Ref. L-5 ↙ MS Geometric 928 ↘ Algebra I 769
 MS Geometric 661
 ↙ TR Julian LT151 ↘ Beckton Julian GG B571
 MS Geometric 917
TR CARRIE RT524
 ↙ BUF Crk Carrie L349 ↘ BUF Crk Canyon 5180
 BUF Crk Carrie 1836

DAM		Calv.Ease	BW	WW	YW	Milk	HPG	Stay	Maint.En.
Age	3	15	-3.9	27	45	14	9	10.9	+6.3
Wt	NA	Marb +06		REA +00		Bfat +00			
Prog.BW	61	BWt	WWt	WR	ADG	YWt	YR	Scr.	Fr.
WR	101	71	626	102	2.55	1034	93	37	4.5
YR	103								
Wean Pct.NA%	NA								
Cow Eff.	NA								

★★★★★ for Calving Ease.

202 **TR JULIAN UT803**
1-A 100% # 1240418Tattoo: TR2A8 UT80

Birth: 3-17-08
 ↙ BKT Julian 7526 G ↘ Beckton Julian 6592
 BKT Belga 6746 GS
TR JULIAN RT554
 Ref. J-12 ↙ Beckton Vernice G373 WR ↘ Beckton Warrior T C371
 Beckton Vernice D066 NM
 ↙ DMW Mmday H17 ↘ BJR Make My Day 981
 Buckeye Rosemary
BUCKEYE YVONNE K97
 ↙ Buckeye Pearl ↘ Glacier Northern KNG656
 Buckeye Tina

DAM		Calv.Ease	BW	WW	YW	Milk	HPG	Stay	Maint.En.
Age	8	12	-4.0	18	39	12	10	12.1	+7.2
Wt	NA	Marb +15		REA +13		Bfat +00			
Prog.BW	80	BWt	WWt	WR	ADG	YWt	YR	Scr.	Fr.
WR	100	78	588	96	3.13	1088	98	40	5.0
YR	100								
Wean Pct.NA%	NA								
Cow Eff.	NA								

★★★★★ for Marbling, Rib-eye area, Calving Ease.



203 **TR JADE UT805**
1-A 100% # 1240445Tattoo: TR2A8 UT80

Birth: 3-11-08
 ↙ Beckton Julian GG B571 ↘ BKT Julian 7526 G
 BKT Marta 9A13 JL
TR JULIAN ST630
 Ref. J-14 ↙ MS Geometric 003 ↘ BJR Make My Day 981
 MS Geometric 277
 ↙ BUF Crk Canyon 5180 ↘ BUF Crk Chf 824-1658
 Bflo Crk Banebery441
BUF CRK CARRIE L349
 ↙ BUF Crk Carrie 1836 ↘ BUF Crk Hobo 1413
 BUF Crk Carrie 1552

DAM		Calv.Ease	BW	WW	YW	Milk	HPG	Stay	Maint.En.
Age	7	14	-3.7	19	36	15	11	12.5	-1.5
Wt	NA	Marb +11		REA +00		Bfat +01			
Prog.BW	79	BWt	WWt	WR	ADG	YWt	YR	Scr.	Fr.
WR	102	80	595	97	3.02	1078	97	36	5.0
YR	100								
Wean Pct.NA%	NA								
Cow Eff.	NA								

★★★★★ for Low Maintenance, Marbling, Calving Ease.

205 **BECKTON JULIAN U469 GG**
1-A 100% # 1258854 Tattoo: WF8 U469

Birth: 3-22-08
 ↙ Beckton Julian 7526G ↘ Beckton Julian 6592
 Bkt Belga 6746 GS
BECKTON JULIAN GG B571
 Ref. J-1 ↙ Bkt Marta 9A13 JL ↘ Beckton Julian 7526G
 Bkt Marta 6498 XM
 ↙ Beckton Herald HH E503 ↘ Beckton Herald H B463
 Beckton Serena B025 HV
BECKTON ENCINO H630 HR
 ↙ Bkt Encino 8459 TJ ↘ Beckton Trojan 7061P
 BCH Kit 7132-784

DAM		Calv.Ease	BW	WW	YW	Milk	HPG	Stay	Maint.En.
Age	10	18	-4.2	25	44	15	11	14	-3.6
Wt	1090	Marb -02		REA +07		Bfat +01			
Prog.BW	70	BWt	WWt	WR	ADG	YWt	YR	Scr.	Fr.
WR	100	76	577	99	3.72	1068	98	37	5.0
YR	100								
Wean Pct.53%	NA								
Cow Eff.	111								

★★★★★ for Low Maintenance, Calving Ease, Stayability. Selling 1/2 Interest & Full Possession.

• Bulls •

206 BECKTON LIKABLE U116
1-A 100% # 1258784 Tattoo: BKT8 U116

Birth: 3-4-08
 Beckton Lancer F442 T
BECKTON LIKABLE S633
 Ref. L-4
 Beckton Kit F468 JL
 Beckton Lancer T A664
 Bkt Suffeina A828 DM
 Beckton Julian GG B571
 Beckton Kit A517 NP
 Beckton Lancer T A664
 Bkt Suffeina A828 DM
BECKTON KIT S545 LN
 Beckton Julian GG B571
 Beckton Kit A517 NP

DAM		Calv.Ease	BW	WW	YW	Milk	HPG	Stay	Maint.En.
Age	2	13	-1.9	28	50	10	8	14	-7.1
Wt	885								
Prog.BW	65								
WR	101		Marb +.19		REA +.48		Bfat -.01		
YR	101								
Wean Pct.	55%	BWt	WWt	WR	ADG	YWt	YR	Scr.	Fr.
Cow Eff.	115	65	543	101	3.42	1021	101	32	5.0

★★★★★ for Low Maintenance, Marbling, Rib-eye area, Calving Ease, Stayability. **Selling ½ Interest & Full Possession.**

209 BECKTON LOKI U023 CL
1-A 100% # 1259119 Tattoo: WF8 U023

Birth: 2-18-08
 Beckton Loki C M740
BECKTON LOKI CL S284
 Ref. L-3
 Beckton Lakme J460 LT
 Beckton Loki F251
 BKT Larkeisa J051 CK
 Beckton Latigo G714
 Beckton Lakme G128 HD
 Beckton Neva 5562
 Bkt Bolt Tamrck 3913
BECKTON MINOLA S483 NM
 Beckton Nomad 7496
 Beckton Minola E589 TO
 BJR Topper 5241
 Beckton Minola B168 SC

DAM		Calv.Ease	BW	WW	YW	Milk	HPG	Stay	Maint.En.
Age	2	13	-3.1	29	49	13	9	11	-2.3
Wt	785								
Prog.BW	64								
WR	103		Marb +.06		REA -.19		Bfat +.00		
YR	100								
Wean Pct.	63%	BWt	WWt	WR	ADG	YWt	YR	Scr.	Fr.
Cow Eff.	132	64	552	103	3.57	1010	100	35	5.0

★★★★★ for Low Maintenance, High Cow Efficiency, Calving Ease.

207 BECKTON COBALT U468
1-A 100% # 1258813 Tattoo: BKT8 U468

Birth: 3-22-08
 Beckton Cody K1 P014
BECKTON COBALT S029
 Ref. C-3
 Beckton Marta P633 JO
 Beckton Cody K1 P014
BECKTON SUSAN S766 CD
 Beckton Susan P857 JO
 Beckton Cody KH M390
 Beckton Rose M126 WR
 Beckton Julio L233
 Beckton Marta C314 JL
 Beckton Cody KH M390
 Beckton Rose M126 WR
 Beckton Julio L233
 Beckton Susan G199 CO

DAM		Calv.Ease	BW	WW	YW	Milk	HPG	Stay	Maint.En.
Age	2	14	-3.9	27	60	18	8	13	-2.4
Wt	880								
Prog.BW	61								
WR	109		Marb -.03		REA +.30		Bfat +.00		
YR	105								
Wean Pct.	60%	BWt	WWt	WR	ADG	YWt	YR	Scr.	Fr.
Cow Eff.	125	61	584	109	4.03	1066	105	38	5.0

★★★★★ for Low Maintenance, Gainability, Rib-eye area, Superior Cow, High Cow Efficiency, Calving Ease, Stayability.

210 BECKTON JULIAN U476 G3
1-A 100% # 1259570 Tattoo: BKT8 U476

Birth: 3-22-08
 Beckton Julian GG B571
BECKTON JULIAN G3 P608
 Ref. J-6
 Bkt Suffeina A828 DM
 Beckton Julian 7526G
 Bkt Marta 9A13 JL
 Beckton Dominor 9455
 Bkt Suffeina 9493 TT
 Beckton Champ RH F275
 Beckton Lana F138 LN
BECKTON LANA R402 CH
 Beckton Champ R1 H024
 Beckton Lana G730 JL
 Beckton Julian GG B571
 Beckton Lana 9841 NM

DAM		Calv.Ease	BW	WW	YW	Milk	HPG	Stay	Maint.En.
Age	3	18	-6.2	21	42	14	13	16	-2.4
Wt	1020								
Prog.BW	65								
WR	109		Marb +.07		REA +.20		Bfat +.00		
YR	104								
Wean Pct.	52%	BWt	WWt	WR	ADG	YWt	YR	Scr.	Fr.
Cow Eff.	110	60	574	101	4.18	1048	97	33	5.0

★★★★★ for Low Maintenance, Gainability, Rib-eye area, Superior Cow, Calving Ease, Stayability.

208 BECKTON NEBULA U348 L
1-A 100% # 1258993 Tattoo: WF8 U348

Birth: 3-18-08
 Beckton Nebula M045
BECKTON NEBULA L P093
 Ref. N-3
 Beckton Marta M021 LN
 Beckton Julian G1 J526
BECKTON MINOLA P611 JL
 Beckton Minola K428 HD
 Beckton Neptune R2 K065
 Beckton Belga K285 JL
 Beckton Lancer TA K644
 Beckton Marta K254 LN
 Beckton Julian GG B571
 Beckton Annie F743 LN
 Beckton Hadrian F C486
 Beckton Minola D330 JL

DAM		Calv.Ease	BW	WW	YW	Milk	HPG	Stay	Maint.En.
Age	4	18	-5.9	27	50	6	10	15	-2.0
Wt	1010								
Prog.BW	62								
WR	103		Marb +.07		REA +.22		Bfat -.01		
YR	101								
Wean Pct.	57%	BWt	WWt	WR	ADG	YWt	YR	Scr.	Fr.
Cow Eff.	119	58	591	101	3.78	1045	96	38	5.0

★★★★★ for Low Maintenance, Rib-eye area, High Cow Efficiency, Calving Ease, Stayability.

211 BECKTON ROMAN U019 J
2 100% # 1259660 Tattoo: BKT8 U019

Birth: 2-17-08
 TR Romeo NT379
BECKTON ROMAN J S158
 Ref. J-9
 Beckton Belga K285 JL
 Buffalo Creek Romeo L081
 Buf Crk Lass L420
 Beckton Julian GG B571
 Beckton Belga G493 HR
 Buffalo Creek Romeo L081
 Buf Crk Lass L420
BKT PINE MARIE S278 RA
 TR Romeo NT379
 BKT Pine Marie J144 EP
 Beckton Epic K F075
 Bkt PineMarie Z465 FF

DAM		Calv.Ease	BW	WW	YW	Milk	HPG	Stay	Maint.En.
Age	2	7	+1.5	42	69	20	10	15	+8.1
Wt	1125								
Prog.BW	72								
WR	106		Marb +.02		REA +.29		Bfat +.01		
YR	97								
Wean Pct.	45%	BWt	WWt	WR	ADG	YWt	YR	Scr.	Fr.
Cow Eff.	95	72	569	106	2.76	984	97	33	5.5

★★★★★ for Rib-eye area, Calving Ease, Stayability.

• Bulls •



214 **BECKTON ROMAN U032 J**
1-A 100% # 1258793 Tattoo: BKT8 U032

Birth: 2-20-08

TR Romeo NT379
Beckton Lancer T9 N586
BKT Larkeisa M816 EP

Buffalo Creek Romeo L081
Buf Crk Lass L420
Beckton Julian GG B571
Beckton Belga G493 HR
Beckton Lancer TA K644
BKT Larkeisa H232 SC
Beckton Epic KJ J722
BKT Larkeisa J076 DM

BECKTON ROMAN J S158
Ref. J-9
Beckton Belga K285 JL

BKT LARKEISA S605 LN

DAM		Calv.Ease	BW	WW	YW	Milk	HPG	Stay	Maint.En.
Age	2	9	+1.2	35	56	16	11	14	-3.2
Wt	850	Marb +.04		REA +.24		Bfat +.01			
Prog.BW	76	BWt	WWt	WR	ADG	YWt	YR	Scr.	Fr.
WR	100	76	569	100	3.27	979	94	35	5.5
YR	94								
Wean Pct.	60%								
Cow Eff.	126								

★★★★★ for Low Maintenance, Rib-eye area, High Cow Efficiency, Calving Ease, Stayability.

212 **BECKTON LEGEND U183**
2 100% # 1259615 Tattoo: BKT8 U183

Birth: 3-11-08

Beckton Lancer F442 T
Beckton Lancer T A664
Bkt Suffeina A828 DM

BECKTON LEGEND S670
Ref. J-9
Beckton Kit F468 JL
Beckton Julian GG B571
Beckton Kit A517 NP

Beckton Lasso P741
Beckton Lancer T1 H080
Beckton Ruth G534 NP

BECKTON LANA S049 LO
Beckton Lana P265 JO
Beckton Julio L233
Beckton Lana J131 CT

DAM		Calv.Ease	BW	WW	YW	Milk	HPG	Stay	Maint.En.
Age	2	12	-1.4	31	55	10	8	14	-8.8
Wt	785	Marb +.13		REA +.28		Bfat -.01			
Prog.BW	68	BWt	WWt	WR	ADG	YWt	YR	Scr.	Fr.
WR	105	68	561	105	3.27	1032	102	33	5.0
YR	102								
Wean Pct.	64%								
Cow Eff.	134								

★★★★★ for Low Maintenance, Marbling, Rib-eye area, High Cow Efficiency, Calving Ease, Stayability.

215 **BECKTON NEBULA U818 E**
1-A 100% # 1258888 Tattoo: WF8 U818

Birth: 4-19-08

Beckton Nebula M045
Beckton Neptune R2 K065
Beckton Belga K285 JL

BECKTON NEBULA E P084
Ref. N-2
BKT Pine Marie M119 EP
Beckton Epic K F075
Bkt Pine Marie D126 JL

Beckton Lancer F442 T
Beckton Lancer T A664
Bkt Suffeina A828 DM

BECKTON LARKABA L536 LN
Beckton Larkaba J300 CH
Beckton Champ RK E121
Beckton Larkaba Z257 ZN

DAM		Calv.Ease	BW	WW	YW	Milk	HPG	Stay	Maint.En.
Age	7	12	-1.9	35	59	12	8	15	-4.1
Wt	1130	Marb +.17		REA +.19		Bfat +.00			
Prog.BW	75	BWt	WWt	WR	ADG	YWt	YR	Scr.	Fr.
WR	102	82	701	120	3.06	1114	102	32	5.0
YR	99								
Wean Pct.	62%								
Cow Eff.	131								

★★★★★ for Low Maintenance, Marbling, Rib-eye area, High Cow Efficiency, Calving Ease, Stayability.

213 **BECKTON JET U276 L**
1-A 100% # 1258966 Tattoo: WF8 U276

Birth: 3-15-08

TR Julian LT151
Beckton Julian GG B571
MS Geometric 917

BECKTON JET L P491
Ref. J-4
Beckton Minerva L278 LN
Beckton Lancer TS D390
Beckton Minerva F495 CH

Beckton Justice CH M056
Beckton Justice C K449
Beckton Ruth K802 HD

BECKTON LANA P159 JC
Beckton Lana M199 JV
Bkt Javelin 7466 R
Beckton Lana K346 CO

DAM		Calv.Ease	BW	WW	YW	Milk	HPG	Stay	Maint.En.
Age	4	18	-6.8	13	31	16	9	14	-4.6
Wt	930	Marb +.14		REA -.04		Bfat -.01			
Prog.BW	59	BWt	WWt	WR	ADG	YWt	YR	Scr.	Fr.
WR	102	61	537	92	3.88	1004	92	36	4.5
YR	97								
Wean Pct.	56%								
Cow Eff.	117								

★★★★★ for Low Maintenance, Marbling, High Cow Efficiency, Calving Ease, Stayability.

216 **BECKTON JET U405 L**
1-A 100% # 1258918 Tattoo: WF8 U405

Birth: 3-20-08

TR Julian LT151
Beckton Julian GG B571
MS Geometric 917

BECKTON JET L P491
Ref. J-4
Beckton Minerva L278 LN
Beckton Lancer TS D390
Beckton Minerva F495 CH

Beckton Warrior CK J861
Beckton Warrior C C355
Bkt Larkaba 8562 KR

BECKTON RUTH M749 WR
Beckton Ruth F125 KA
Beckton Kannon D202
Beckton Ruth D247 KR

DAM		Calv.Ease	BW	WW	YW	Milk	HPG	Stay	Maint.En.
Age	6	13	-3.9	21	35	15	8	13	+0.9
Wt	1080	Marb +.09		REA +.11		Bfat +.00			
Prog.BW	77	BWt	WWt	WR	ADG	YWt	YR	Scr.	Fr.
WR	102	72	545	94	3.67	988	91	36	5.0
YR	97								
Wean Pct.	51%								
Cow Eff.	106								

★★★★★ for Low Maintenance, Calving Ease, Stayability.

• Bulls •

217 **BECKTON JET U419 L**
1-A 100% # 1258882 Tattoo: WF8 U419

Birth: 3-20-08
 TR Julian LT151
 Beckton Julian GG B571
 MS Geometric 917
BECKTON JET L P491
 Ref. J-4 Beckton Minerva L278 LN
 Beckton Lancer TS D390
 Beckton Minerva F495 CH
 Beckton Lancer T A664
 Beckton Coca 7536 SB
BECKTON TAMARA L214 LN
 Beckton Lancer TS D390
 Beckton Tamara A023 BF
 BUF CRK 27M-1255
 Bkt Tamara 9857 VK

DAM		Calv.Ease	BW	WW	YW	Milk	HPG	Stay	Maint.En.
Age	7	17	-7.5	13	25	18	6	14	+1.3
Wt	1140	Marb +.15		REA -.16		Bfat -.01			
Prog.BW	76	BWt	WWt	WR	ADG	YWt	YR	Scr.	Fr.
WR	102	63	564	97	3.47	988	91	35	4.5
YR	103								
Wean Pct.	50%								
Cow Eff.	104								

★★★★★ for Low Maintenance, Marbling, Calving Ease, Stayability.

219 **BKT CHEROKEE U665 N**
1-A 100% # 1259361 Tattoo: BKT8 U665

Birth: 4-1-08
 BFCK Cherokee Cnyn 4912
 BUF CRK Chief 824-1658
 MRM 1431 8611 9109
BECKTON CHEROKEE N N479
 Ref. B-1 Beckton Dinah C440 NM
 Beckton Nomad K 9949
 Beckton Dinah Z610 JL
 RDD B Topper 1675
 Bieber Topper 2476
BECKTON SUSAN F315 TP
 Beckton Susan 9785VK
 RR Miss Dynamo 7202
 Beckton Viking 8099X
 SOR Susie TP HW-888

DAM		Calv.Ease	BW	WW	YW	Milk	HPG	Stay	Maint.En.
Age	12	10	-4.3	22	30	20	8	9	-3.0
Wt	1180	Marb +.06		REA +.27		Bfat +.01			
Prog.BW	78	BWt	WWt	WR	ADG	YWt	YR	Scr.	Fr.
WR	100	72	603	98	3.62	1030	93	36	5.0
YR	101								
Wean Pct.	49%								
Cow Eff.	104								

★★★★★ for Low Maintenance, Rib-eye area, Calving Ease.

218 **BECKTON NEBULA U136 EN**
1-A 100% # 1259086 Tattoo: WF8 U136

Birth: 3-6-08
 Beckton Nebula E P084
 Beckton Nebula M045
 BKT Pine Marie M119 EP
BECKTON NEBULA EN S347
 Ref. N-7 Beckton Eola P530 NB
 Beckton Nebula M045
 Beckton Eola M663 EP
 Beckton Nebula M045
 BKT Pine Marie M119 EP
BECKTON CHRISTY S151 NB
 Beckton Nebula E P084
 Beckton Christy P333 CH
 Beckton Champ R1 H024
 Beckton Christy K209 CO

DAM		Calv.Ease	BW	WW	YW	Milk	HPG	Stay	Maint.En.
Age	2	16	-5.1	26	49	13	10	17	-9.8
Wt	790	Marb +.21		REA +.18		Bfat +.01			
Prog.BW	61	BWt	WWt	WR	ADG	YWt	YR	Scr.	Fr.
WR	107	61	572	107	3.67	998	98	34	5.0
YR	98								
Wean Pct.	65%								
Cow Eff.	137								

★★★★★ for Low Maintenance, Marbling, Rib-eye area, High Cow Efficiency, Calving Ease, Stayability.

220 **BECKTON JULIO U732**
1-A 100% # 1259033 Tattoo: WF8 U732

Birth: 4-8-08
 Beckton Julian G1 J526
 Beckton Julian GG B571
 Beckton Annie F743 LN
BECKTON JULIO L233
 Ref. J-2 Beckton Rose J725 EP
 Beckton Epic K F075
 Beckton Rose F192 CL
 Beckton Epic D404
 Beckton Belga D483 KR
BKT SUFFEINA R231 EP
 Beckton Epic K F075
 Bkt Suffeina A828 DM
 Beckton Dominor 9455
 Bkt Suffeina 9493 TT

DAM		Calv.Ease	BW	WW	YW	Milk	HPG	Stay	Maint.En.
Age	3	13	-5.4	18	49	11	10	12	-10.4
Wt	835	Marb +.15		REA +.10		Bfat +.01			
Prog.BW	61	BWt	WWt	WR	ADG	YWt	YR	Scr.	Fr.
WR	92	62	550	96	4.13	1090	101	36	4.5
YR	97								
Wean Pct.	61%								
Cow Eff.	129								

★★★★★ for Low Maintenance, Gainability, Marbling, High Cow Efficiency, Calving Ease.



221 **BSF VEGA U758**
1-B 99% # 1259243 Tattoo: BSF8 U758

Birth: 4-10-08
 Beckton Vegas S1 K316
 Beckton Vegas SV H078
 Beckton Eola H073 EP
BECKTON VEGA P079
 Ref. V-1 Beckton Lydia H159 JL
 Beckton Julian GG B571
 Beckton Lydia D386 CL
 Beckton Julian GG B571
 Beckton Lana H544 WR
BSF JULIANNE P204
 BSF Regus M298 WR
 Beckton Warrior T C371
 BSF Regus J475

DAM		Calv.Ease	BW	WW	YW	Milk	HPG	Stay	Maint.En.
Age	4	15	-3.1	19	48	12	11	13	-0.2
Wt	1010	Marb +.02		REA +.27		Bfat -.01			
Prog.BW	62	BWt	WWt	WR	ADG	YWt	YR	Scr.	Fr.
WR	87	71	519	89	4.64	1049	96	34	5.0
YR	95								
Wean Pct.	49%								
Cow Eff.	104								

★★★★★ for Low Maintenance, Gainability, Rib-eye area, Calving Ease, Stayability.

• Bulls •

222 **BSF JULIAN U712 GJ**
1-B 99% # 1259275 Tattoo: BSF8 U712

Birth: 4-5-08
 Beckton Julian 7526G
BECKTON JULIAN GJ P535
 Ref. J-5
 Beckton Mona D086 JL
 Beckton Julian 6592
 Bkt Belga 6746 GS
 Beckton Julian GV Z693
 Beckton Mona 9356 KR
 Beckton Lancer TA K644
 BKT Larkeisa H232 SC
BSF LAUREL R342 LN
 Beckton Lancer T9 N586
 BSF Laurel N198 LN
 Beckton Lancer TH K417
 BSF Regus HA25

DAM		Calv.Ease	BW	WW	YW	Milk	HPG	Stay	Maint.En.
Age	3	14	-3.3	24	54	6	13	14	-0.5
Wt	905	Marb +1.0		REA +0.03		Bfat +0.00			
Prog.BW	65	BWt	WWt	WR	ADG	YWt	YR	Scr.	Fr.
WR	94	69	569	98	3.62	1070	100	34	5.0
YR	95								
Wean Pct.	59%								
Cow Eff.	123								

★★★★★ for Low Maintenance, High Cow Efficiency, Calving Ease, Stayability.

225 **BSF JET U252 L**
1-B 99% # 1259284 Tattoo: BSF8 U252

Birth: 3-14-08
 TR Julian LT151
BECKTON JET L P491
 Ref. J-4
 Beckton Minerva L278 LN
 Beckton Julian GG B571
 MS Geometric 917
 Beckton Lancer TS D390
 Beckton Minerva F495 CH
 Beckton Julian GG B571
 Beckton Annie F743 LN
BSF JULIANNE R635 JL
 Beckton Julian G1 J526
 BSF Regus M132 HA
 Beckton Harmony K049
 BSF Regus K895 CO

DAM		Calv.Ease	BW	WW	YW	Milk	HPG	Stay	Maint.En.
Age	3	15	-4.8	20	42	14	8	16	+4.1
Wt	1105	Marb +1.0		REA +0.05		Bfat +0.00			
Prog.BW	58	BWt	WWt	WR	ADG	YWt	YR	Scr.	Fr.
WR	92	68	509	88	3.67	972	91	35	4.5
YR	93								
Wean Pct.	42%								
Cow Eff.	89								

★★★★★ for Calving Ease, Stayability.

223 **BSF EMCEE U220**
1-B 99% # 1259310 Tattoo: BSF8 U220

Birth: 3-13-08
 Beckton Epic K4 N795
BECKTON EMCEE S466
 Ref. E-4
 Beckton Larkaba H798 WR
 Beckton Epic KH P678
BSF JULIANNE S109 EP
 BSF Julianne P152
 Beckton Epic KJ J722
 Beckton Sierra J789 EP
 Beckton Warrior T C371
 Beckton Larkaba E042 CD
 Beckton Epic K F075
 BKT Larkeisa L274 HU
 Beckton Julian G2 M345
 BSF Regus M352 CD

DAM		Calv.Ease	BW	WW	YW	Milk	HPG	Stay	Maint.En.
Age	2	13	-3.0	32	58	17	10	11	-1.9
Wt	735	Marb +1.13		REA +0.24		Bfat -0.01			
Prog.BW	62	BWt	WWt	WR	ADG	YWt	YR	Scr.	Fr.
WR	114	62	609	114	3.21	1009	99	34	5.5
YR	99								
Wean Pct.	75%								
Cow Eff.	157								

★★★★★ for Low Maintenance, Marbling, Rib-eye area, High Cow Efficiency, Calving Ease.



224 **BECKTON CHEROKEE U856 N**
1-A 100% # 1259400 Tattoo: BKT8 U856

Birth: 4-29-08
 BFCK Cherokee Cnyn 4912
BECKTON CHEROKEE N N479
 Ref. B-1
 Beckton Dinah C440 NM
 Beckton Epic D404
BECKTON MINOLA K538 EP
 Beckton Minola Z505 KR
 BUF CRK Chief 824-1658
 MRM 1431 8611 9109
 Beckton Nomad K 9949
 Beckton Dinah Z610 JL
 Beckton Saga KJ B702
 Beckton Kuruba B508 PC
 Beckton Kaiser 7143F
 Bkt Minola 7697 NV

DAM		Calv.Ease	BW	WW	YW	Milk	HPG	Stay	Maint.En.
Age	8	15	-5.5	20	41	15	9	10	-5.8
Wt	1150	Marb +1.10		REA +0.01		Bfat +0.02			
Prog.BW	67	BWt	WWt	WR	ADG	YWt	YR	Scr.	Fr.
WR	97	62	595	97	4.39	1112	100	37	4.5
YR	99								
Wean Pct.	52%								
Cow Eff.	109								

★★★★★ for Low Maintenance, Gainability, Calving Ease.

226 **BECKTON WARRIOR U256 C1**
1-A 100% # 1259639 Tattoo: BKT8 U256

Birth: 3-14-08
 Beckton Warrior CL M686
BECKTON WARRIOR C1 S337
 Ref. W-2
 Beckton Christy K101 CD
 Beckton Warrior CL M686
BKT PINE MARIE S139 WR
 BKT Pine Marie N719 EP
 Beckton Warrior C C355
 Beckton Christy J223 LN
 Beckton Cody V E023
 Beckton Christy C306 JL
 Beckton Warrior C C355
 Beckton Christy J223 LN
 Beckton Epic KJ J722
 BKT Pine Marie H379 LA

DAM		Calv.Ease	BW	WW	YW	Milk	HPG	Stay	Maint.En.
Age	2	18	-5.1	25	58	11	10	11	-0.2
Wt	875	Marb +0.04		REA +0.12		Bfat +0.00			
Prog.BW	52	BWt	WWt	WR	ADG	YWt	YR	Scr.	Fr.
WR	94	52	501	94	4.59	1027	101	36	4.5
YR	101								
Wean Pct.	50%								
Cow Eff.	106								

★★★★★ for Low Maintenance, Gainability, Calving Ease.

• Bulls •

227 **BECKTON JULIAN U723 GJ**
1-A 100% # 1259601 Tattoo: BKT8 U723

Birth: 4-7-08
 Beckton Julian 7526G
BECKTON JULIAN GJ P535
 Ref. J-5
 Beckton Mona D086 JL
 Beckton Julian 6592
 Bkt Belga 6746 GS
 Beckton Julian GV Z693
 Beckton Mona 9356 KR
 Beckton Epic KJ J722
 Beckton Lana F268 CT
BECKTON SHEBA R753 EP
 Beckton Sheba M054 JC
 Beckton Justice C K449
 Beckton Sheba K206 JC

DAM		Calv.Ease	BW	WW	YW	Milk	HPG	Stay	Maint.En.
Age	3	16	-5.6	21	45	5	12	14	-1.4
Wt	915	Marb +0.12		REA +0.13		Bfat +0.00			
Prog.BW	60	BWt	WWt	WR	ADG	YWt	YR	Scr.	Fr.
WR	97	60	553	97	3.67	1024	95	36	5.0
YR	94								
Wean Pct.	56%								
Cow Eff.	118								

★★★★★ for Low Maintenance, Marbling, Rib-eye area, High Cow Efficiency, Calving Ease, Stayability.

229 **BSF EMCEE U286**
1-B 99% # 1259305 Tattoo: BSF8 U286

Birth: 3-15-08
 Beckton Epic K4 N795
BECKTON EMCEE S466
 Ref. E-4
 Beckton Larkaba H798 WR
 Beckton Epic KJ J722
 Beckton Sierra J789 EP
 Beckton Warrior T C371
 Beckton Larkaba E042 CD
 Beckton Epic K F075
 BKT Larkeisa L274 HU
BSF JULIANNE S013 EP
 BSF Julianne P332
 Beckton Julian G2 M345
 BSF Regus M835 JL

DAM		Calv.Ease	BW	WW	YW	Milk	HPG	Stay	Maint.En.
Age	2	13	-3.6	25	56	15	10	13	+3.9
Wt	990	Marb +0.23		REA +0.01		Bfat -0.01			
Prog.BW	60	BWt	WWt	WR	ADG	YWt	YR	Scr.	Fr.
WR	93	60	530	93	3.42	980	95	35	5.5
YR	95								
Wean Pct.	48%								
Cow Eff.	100								

★★★★★ for Low Maintenance, Marbling, Calving Ease, Stayability.



230 **BSF WARRIOR U438 C1**
1-B 99% # 1259327 Tattoo: BSF8 U438

Birth: 3-21-08
 Beckton Warrior CL M686
BECKTON WARRIOR C1 S337
 Ref. W-2
 Beckton Christy K101 CD
 Beckton Epic KJ J722
 Beckton Lana F268 CT
BSF HELENA S410 EP
 BSF Helena N151 HU
 Beckton Warrior C C355
 Beckton Christy J223 LN
 Beckton Cody V E023
 Beckton Christy C306 JL
 Beckton Epic KJ J722
 Beckton Lana F268 CT
 Beckton Hustler CN J102
 BSF Regus F175

DAM		Calv.Ease	BW	WW	YW	Milk	HPG	Stay	Maint.En.
Age	2	14	-4.0	28	52	15	11	10	-0.7
Wt	760	Marb +0.09		REA +0.20		Bfat -0.01			
Prog.BW	60	BWt	WWt	WR	ADG	YWt	YR	Scr.	Fr.
WR	103	60	554	103	4.03	993	98	35	5.0
YR	98								
Wean Pct.	65%								
Cow Eff.	137								

★★★★★ for Low Maintenance, Gainability, Rib-eye area, High Cow Efficiency, Calving Ease.

228 **BSF JULIAN U718 GJ**
1-B 99% # 1259289 Tattoo: BSF8 U718

Birth: 4-6-08
 Beckton Julian 7526G
BECKTON JULIAN GJ P535
 Ref. J-5
 Beckton Mona D086 JL
 Beckton Julian G1 J526
BSF JULIANNE R707 JL
 BSF Regus L568 LN
 Beckton Julian 6592
 Bkt Belga 6746 GS
 Beckton Julian GV Z693
 Beckton Mona 9356 KR
 Beckton Julian GG B571
 Beckton Annie F743 LN
 Beckton Lancer T A664
 BSF Regus H166

DAM		Calv.Ease	BW	WW	YW	Milk	HPG	Stay	Maint.En.
Age	3	17	-4.1	34	59	5	11	15	-0.9
Wt	985	Marb +0.09		REA +0.11		Bfat +0.01			
Prog.BW	65	BWt	WWt	WR	ADG	YWt	YR	Scr.	Fr.
WR	106	65	605	106	3.21	1074	100	35	5.0
YR	107								
Wean Pct.	57%								
Cow Eff.	121								

★★★★★ for Low Maintenance, Superior Cow, High Cow Efficiency, Calving Ease, Stayability.

231 **BSF NEBULA U808 N**
1-B 99% # 1259195 Tattoo: BSF8 U808

Birth: 4-18-08
 Beckton Nebula M045
BECKTON NEBULA N R573
 Ref. N-5
 Beckton Lana M621 LN
 Beckton Lancer TL G626
BSF RED ROAN L823 LN
 BSF Regus F207
 Beckton Neptune R2 K065
 Beckton Belga K285 JL
 Beckton Lancer F442 T
 Beckton Lana H329 HD
 Beckton Lancer T A664
 Beckton Fayette C110 LN
 Beckton Caesar M D023
 BSF Regus D006

DAM		Calv.Ease	BW	WW	YW	Milk	HPG	Stay	Maint.En.
Age	7	15	-3.6	25	40	12	6	14	-3.0
Wt	1185	Marb +0.16		REA +0.05		Bfat -0.01			
Prog.BW	67	BWt	WWt	WR	ADG	YWt	YR	Scr.	Fr.
WR	103	68	603	98	3.42	1025	92	42	5.0
YR	100								
Wean Pct.	51%								
Cow Eff.	107								

★★★★★ for Low Maintenance, Marbling, Calving Ease, Stayability.

• Bulls •

232 **BSF HASTEN U784 H**
1-B 99% # 1259320 Tattoo: BSF8 U784

Birth: 4-14-08
 ↗ Beckton Hasten P292 ↘ Beckton Hustler C2 L079
 ↗ Beckton Sheba L644 CH
BECKTON HASTEN H S462
 Ref. H-3 ↘ Beckton Lakme G128 HD ↘ Beckton Hadrian FC E166
 ↘ Beckton Lakme E373 CL
 ↗ Beckton Jules L429 ↘ Beckton Julian G1 J526
BSF VIOLET S326 JE
 ↗ BSF Violet N382 VG ↘ Beckton Barona J591 EP
 ↘ BSF Red H119 ↘ Beckton Vegas S1 K316

DAM		Calv.Ease	BW	WW	YW	Milk	HPG	Stay	Maint.En.
Age	2	12	-2.9	36	67	17	9	11	+5.2
Wt	990	Marb +.02		REA +.17		Bfat +.00			
Prog.BW	60	BWt	WWt	WR	ADG	YWt	YR	Scr.	Fr.
WR	109	60	581	109	3.72	1047	103	35	5.0
YR	103								
Wean Pct.	53%								
Cow Eff.	111								

★★★★★ for Rib-eye area, Superior Cow, Calving Ease.

235 **BSF LIKABLE U543**
1-B 99% # 1259321 Tattoo: BSF8 U543

Birth: 3-24-08
 ↗ Beckton Lancer F442 T ↘ Beckton Lancer T A664
 ↘ Bkt Suffeina A828 DM
BECKTON LIKABLE S633
 Ref. L-4 ↘ Beckton Kit F468 JL ↘ Beckton Julian GG B571
 ↘ Beckton Kit A517 NP
 ↗ Beckton Nexus L016 ↘ Beckton Neptune R1 J245
BSF HELENA S351 NX
 ↗ BSF Helena N012 HU ↘ Beckton Coca J276 CL
 ↘ BSF Regus L199 VG ↘ Beckton Hustler C2 L079

DAM		Calv.Ease	BW	WW	YW	Milk	HPG	Stay	Maint.En.
Age	2	11	-1.9	31	59	12	9	11	+2.5
Wt	1080	Marb +.11		REA +.20		Bfat -.01			
Prog.BW	72	BWt	WWt	WR	ADG	YWt	YR	Scr.	Fr.
WR	92	72	495	92	3.83	976	96	35	5.0
YR	96								
Wean Pct.	40%								
Cow Eff.	85								

★★★★★ for Low Maintenance, Marbling, Rib-eye area, Calving Ease.

233 **BECKTON EPIC U442 K7**
1-A 100% # 1258821 Tattoo: BKT8 U442

Birth: 3-21-08
 ↗ Beckton Epic KJ J722 ↘ Beckton Epic K F075
 ↘ Beckton Lana F891 JL
BECKTON EPIC K7 S583
 Ref. ↘ Beckton Kit F468 JL ↘ Beckton Julian GG B571
 ↘ Beckton Kit A517 NP
 ↗ Beckton Julian G1 J526 ↘ Beckton Julian GG B571
BECKTON LANA S858 JL
 ↘ Beckton Annie F743 LN
 ↘ Beckton Loki F251
 ↘ Beckton Lana D232 HV ↘ Beckton Lana N869 LO

DAM		Calv.Ease	BW	WW	YW	Milk	HPG	Stay	Maint.En.
Age	2	12	-0.7	32	54	13	9	15	-6.1
Wt	835	Marb +.10		REA +.14		Bfat +.00			
Prog.BW	65	BWt	WWt	WR	ADG	YWt	YR	Scr.	Fr.
WR	104	65	558	104	3.21	988	97	33	5.0
YR	97								
Wean Pct.	60%								
Cow Eff.	126								

★★★★★ for Low Maintenance, Rib-eye area, High Cow Efficiency, Calving Ease, Stayability.



234 **BECKTON NEBULA U714 P**
1-A 100% # 1259589 Tattoo: BKT8 U714

Birth: 4-5-08
 ↗ Beckton Nebula M045 ↘ Beckton Neptune R2 K065
 ↘ Beckton Belga K285 JL
BECKTON NEBULA P P707
 Ref. N-4 ↘ Beckton Lana M809 EP ↘ Beckton Epic K1 K863
 ↘ Beckton Lana K253 DM
 ↗ Beckton Epic KM M115 ↘ Beckton Epic K F075
BECKTON LAKME R602 EP
 ↘ Beckton Minerva F495 CH
 ↘ RDD B Topper 1675
 ↘ Beckton Lakme 8192NV ↘ Beckton Lakme F560 TP

DAM		Calv.Ease	BW	WW	YW	Milk	HPG	Stay	Maint.En.
Age	3	13	-3.9	31	54	15	7	11	+1.8
Wt	1180	Marb +.10		REA -.02		Bfat +.01			
Prog.BW	66	BWt	WWt	WR	ADG	YWt	YR	Scr.	Fr.
WR	92	67	545	96	3.27	991	92	34	5.0
YR	88								
Wean Pct.	43%								
Cow Eff.	90								

★★★★★ for Low Maintenance, Calving Ease.

236 **BECKTON JUSTICE U861 C1**
1-A 100% # 1259525 Tattoo: BKT8 U861

Birth: 5-4-08
 ↗ Beckton Justice CH M056 ↘ Beckton Justice C K449
 ↘ Beckton Ruth K802 HD
BECKTON JUSTICE C1 R483
 Ref. J-7 ↘ Beckton Tamara J124 HR ↘ Beckton Herald F FA20
 ↘ Beckton Tamara F183 CT
 ↗ Beckton Justice Cc N265 ↘ Beckton Justice C K449
BECKTON SERENA R023 JC
 ↘ Beckton Rose H303 CL
 ↘ Beckton Justice G302
 ↘ Beckton Serena N469 JC ↘ Beckton Serena D128 NP

DAM		Calv.Ease	BW	WW	YW	Milk	HPG	Stay	Maint.En.
Age	3	13	-3.1	30	64	11	11	10	+1.2
Wt	915	Marb +.12		REA +.10		Bfat -.01			
Prog.BW	66	BWt	WWt	WR	ADG	YWt	YR	Scr.	Fr.
WR	109	68	592	102	4.03	1065	99	33	5.0
YR	104								
Wean Pct.	60%								
Cow Eff.	127								

★★★★★ for Low Maintenance, Gainability, Marbling, Superior Cow, High Cow Efficiency, Calving Ease.

The Yearling Heifers

The Beckton cowherd is a complete package of genetics for today's industry – moderately sized, efficient producers. They combine calving ease, growth, and desirable carcass traits. They are feminine, maternal and quiet, with nice udders. All of our heifer calves trailed up with their mothers into the Bighorn Mountains to spend their first summer. They have learned the meaning of mothering ability. Most impressively, heifers like these produce the bulls for our sale.

We have included heifers from the very top of our replacements. They also include a very nice set

of heifers from Tongue River Red Angus that are predominantly Beckton breeding. All have received a vaccination for leptovibrio this spring, but have not had MGA or other additives to suppress heat and influence gains. These heifers were born mostly in February and March. They are cycling and ready to breed.

We can keep any sale heifers and breed them in natural service to the same herd sires we use with our own heifers. There will be a charge of \$250 per heifer plus delivery at cost in the fall. Visit with Cam.



Special Offer

Beckton is offering 2 straws of semen from any Beckton sire (for which we have semen), to go free of charge with each Beckton heifer purchased. If the sire selected is Beckton Julian B571, the offer is only for 1 straw, and is available only on Beckton 1-A heifers purchased. The buyer will only be responsible for shipping costs from Billings (unless the heifer is being left for breeding at Beckton). The buyer may use the semen on any animals he/she chooses.

Tongue River is likewise offering 2 straws of semen from any Tongue River sire available, for each Tongue River heifer purchased.

• Heifers •

301 BECKTON TAMARA U628 JL
1-A 100% # 1259540 Tattoo: BKT8 U628

Birth: 3-29-08

Beckton Julian 7526G
Beckton Julian 6592
Bkt Belga 6746 GS

BECKTON JULIAN GG B571
Ref. J-1
Bkt Marta 9A13 JL

Beckton Lancer T9 N586
Beckton Lancer TA K644
BKT Larkeisa H232 SC

BECKTON TAMARA R149 LN
Beckton Tamara N530 LN
Beckton Lancer TA K644
Beckton Tamara K021 CH

DAM		Calv.Ease	BW	WW	YW	Milk	HPG	Stay	Maint.En.
Age	3	17	-2.4	30	59	12	13	16	-4.3
Wt	930	Marb	+1.0	REA	+2.5	Bfat	.01	BWt	72
Prog.BW	68	WR	105	YR	107	Fr.	107	med	
WR	105								
YR	107								
Cow Eff.	104								

We lead off with an own daughter of Julian B571, from a top young cow. The Tamara cow line has produced top herd sire prospects in 2 of our last 3 sales. This wonderful heifer combines femininity with a very low Maintenance EPD, plenty of growth, and excellent carcass EPD's.



303 BECKTON ROSE U791 JT
1-A 100% # 1259599 Tattoo: BKT8 U791

Birth: 4-15-08

TR Julian LT151
Beckton Julian GG B571
MS Geometric 917

BECKTON JET L P491
Ref. J-4
Beckton Minerva L278 LN

Beckton Lancer T6 M467
Beckton Lancer TS D390
Beckton Minerva F495 CH

BECKTON ROSE R711 LN
Beckton Rose L311 LN
Beckton Lancer TL G626
Beckton Lana C735 TP

DAM		Calv.Ease	BW	WW	YW	Milk	HPG	Stay	Maint.En.
Age	3	17	-6.4	19	48	17	8	14	+0.5
Wt	945	Marb	+1.4	REA	+1.1	Bfat	-0.01	BWt	58
Prog.BW	56	WR	104	YR	104	Fr.	104	med	
WR	104								
YR	104								
Cow Eff.	109								

Rose is also out of a dam that performs well above average, though younger. Like our other heifers, Rose is very moderate in size, and brings excellent balanced EPD's.

304 BECKTON LANA U320 JL
1-A 100% # 1259436 Tattoo: BKT8 U320

Birth: 3-16-08

Beckton Julian GG B571
Bkt Marta 9A13 JL

BECKTON JULIAN G3 P608
Ref. J-6
Bkt Suffeina A828 DM

Beckton Lancer F442 T
Beckton Lancer T A664
Bkt Suffeina A828 DM

BECKTON LANA M435 LN
Beckton Lana H329 HD
Beckton Hadrian FH E143
Beckton Lana D288 VG

DAM		Calv.Ease	BW	WW	YW	Milk	HPG	Stay	Maint.En.
Age	6	12	-0.3	30	58	13	11	14	+0.6
Wt	1200	Marb	+1.2	REA	+2.5	Bfat	.00	BWt	82
Prog.BW	75	WR	110	YR	110	Fr.	108	108 med	
WR	110								
YR	110								
Cow Eff.	92								

Terrific EPD's, from Calving Ease to carcass traits. Again and again when we pick nice heifers for the sale, we find they come from terrific dams. Look at the dam's record here from the Lana family.

302 BECKTON INDIGO U848 CT
1-A 100% # 1258828 Tattoo: WF8 U848

Birth: 4-27-08

Beckton Clifftop T C075
BJR Topper 5241
Beckton Barmaid A761 TR

BKT CLIFFTOP TP R288
Ref. B-3
Beckton Christy K209 CO

Beckton Julian GN 9A45
Beckton Julian 7526G
Beckton Lakme 8192NV

BECKTON INDIGO D780 JL
Beckton Indigo Z193 DM
Beckton Dominor 9455
Bkt Indigo 9315 GL

DAM		Calv.Ease	BW	WW	YW	Milk	HPG	Stay	Maint.En.
Age	14	10	-1.8	24	47	14	12	12	-4.1
Wt	1170	Marb	+0.04	REA	+1.3	Bfat	.00	BWt	73
Prog.BW	74	WR	104	YR	106	Fr.	109	med	
WR	104								
YR	106								
Cow Eff.	95								

Heifers out of great dams usually become great dams in turn. Indigo's dam is now 15 years young and still going great, never missing, and producing low birth weight calves which averaged 104 ratio at weaning and 106 at yearling.

305 BECKTON TAMARA U267 EP
1-A 100% # 1258925 Tattoo: WF8 U267

Birth: 3-15-08

Beckton Epic K F075
Beckton Epic D404
Beckton Belga D483 KR

BECKTON EPIC KM M115
Ref. E-1
Beckton Minerva F495 CH

Beckton Lancer T5 L095
Beckton Lancer F442 T
Beckton Belga J293 HR

BECKTON TAMARA N095 LN
Beckton Tamara L214 LN
Beckton Lancer TS D390
Beckton Tamara A023 BF

DAM		Calv.Ease	BW	WW	YW	Milk	HPG	Stay	Maint.En.
Age	5	7	+1.0	40	70	21	4	11	+4.7
Wt	1050	Marb	+0.03	REA	-0.09	Bfat	.01	BWt	83
Prog.BW	74	WR	106	YR	102	Fr.	110	110 med	
WR	106								
YR	102								
Cow Eff.	110								

The Tamara family shows up again in this nice heifer, as does high milk production and growth. She was a high performer herself, albeit in a moderate size.

• Heifers •

306 BECKTON TAMARA U322 JL
1-A 100% # 1259385 Tattoo: BKT8 U322

Birth: 3-17-08

Beckton Julian GG B571
 Beckton Julian 7526G
 Bkt Marta 9A13 JL

BECKTON JULIAN G1 J526
Ref.

Beckton Annie F743 LN
 Beckton Lancer T A664
 Beckton Annie C132 NP

Beckton Neptune RR B284
 Bkt Neptune 8460 R
 Beckton Eola 8600 RR

BECKTON TAMARA J229 NP

Beckton Tamara C931 CL
 Beckton Clipper JB A559
 Beckton Tamara A553 LN

DAM		Calv.Ease	BW	WW	YW	Milk	HPG	Stay	Maint.En.
Age	9	13	-3.1	36	55	9	8	12	-4.5
Wt	1100								
Prog.BW	74								
WR	101								
YR	100								
Cow Eff.	105								
		Marb	REA	Bfat		BWt	WR	YR	Fr.
		-.08	+.01	-.01		72	107	102	med

One might credit the Tamara cows for fertility and longevity also. This heifer's dam is now 10 and doing well for us. Neither Tamara has ever missed a calf, and on production holds up well against the newer, younger cows.

308 BECKTON DINAH U135 EP
1-A 100% # 1258872 Tattoo: WF8 U135

Birth: 3-6-08

Beckton Epic K F075
 Beckton Epic D404
 Beckton Belga D483 KR

BECKTON EPIC KM M115
Ref. E-1

Beckton Minerva F495 CH
 Beckton Champ R A583
 Beckton Minerva CB69 JL

Beckton Hustler C G407
 LCC Heaven or Bust 1000B
 Beckton Rose E032 CL

BECKTON DINAH K287 HU

Beckton Dinah G334 CT
 Beckton Cliffot T C075
 Beckton Dinah C440 NM

DAM		Calv.Ease	BW	WW	YW	Milk	HPG	Stay	Maint.En.
Age	8	9	+0.5	41	80	20	8	10	+0.1
Wt	1090								
Prog.BW	66								
WR	105								
YR	105								
Cow Eff.	111								
		Marb	REA	Bfat		BWt	WR	YR	Fr.
		+.05	+.03	-.01		78	112	115	lar

This terrific heifer really does it all. +80 for yearling, +20 for Milk, and 0 for Maintenance EPD. Fertility and longevity from a Dinah (as in Dinahmite) dam that is calving this year at nine, with progeny averages of just 66 pounds at birth, and 105 calf ratios at weaning and yearling.

307 BECKTON FIREFLY U608 CD
1-A 100% # 1259537 Tattoo: BKT8 U608

Birth: 3-28-08

Beckton Cody KH M390
 Beckton Cody K G701
 Beckton Tamara J124 HR

BECKTON CODY K2 R168
Ref. C-2

Beckton Tamara K249 VG
 Beckton Vegas SV H078
 Beckton Tamara HA38 WR

Beckton Colt K M609
 Beckton Colt G552
 Beckton Angel H164 LO

BECKTON FIREFLY R134 CK

Beckton Firefly E020 WR
 Beckton Warrior C C355
 Beckton Firefly C394 RN

DAM		Calv.Ease	BW	WW	YW	Milk	HPG	Stay	Maint.En.
Age	3	12	-5.8	23	58	14	7	8	+5.4
Wt	1010								
Prog.BW	65								
WR	98								
YR	110								
Cow Eff.	96								
		Marb	REA	Bfat		BWt	WR	YR	Fr.
		-.01	+.04	.01		60	98	110	med

U608's dam is still young, but looking in the pedigree there is a lot of fertility and longevity. Her maternal grand-dam never missed and was pregnant again when we sold her at age 11.

309 BECKTON SHEBA U304 JL
1-A 100% # 1259449 Tattoo: BKT8 U304

Birth: 3-16-08

Beckton Julian 7526G
 Beckton Julian 6592
 Bkt Belga 6746 GS

BECKTON JULIAN GJ P535
Ref. J-5

Beckton Mona D086 JL
 Beckton Julian GV Z693
 Beckton Mona 9356 KR

Beckton Loki F251
 Beckton Lancer TZ D525
 Bkt Pine Marie D126 JL

BECKTON SHEBA MB04 LO

Beckton Sheba G733 HR
 Beckton Herald K B244
 Beckton Sheba CB73 JL

DAM		Calv.Ease	BW	WW	YW	Milk	HPG	Stay	Maint.En.
Age	6	16	-5.2	26	51	9	10	14	+0.7
Wt	1165								
Prog.BW	64								
WR	109								
YR	102								
Cow Eff.	93								
		Marb	REA	Bfat		BWt	WR	YR	Fr.
		+.15	+.05	.01		58	101	100	med

She is a Julian-Lancer combination with tremendous calving ease. If we judge future production from the dam, her dam averaged 109 weaning ratio on her calves with every calf in the upper end of the crop.



310 BKT LARKEISA U184 EP
1-A 100% # 1259446 Tattoo: BKT8 U184

Birth: 3-11-08

Beckton Epic K F075
 Beckton Epic D404
 Beckton Belga D483 KR

BECKTON EPIC KM M115
Ref. E-1

Beckton Minerva F495 CH
 Beckton Champ R A583
 Beckton Minerva CB69 JL

Beckton Epic KJ J722
 Beckton Epic K F075
 Beckton Lana F891 JL

BKT LARKEISA M816 EP

BKT Larkeisa J076 DM
 Beckton Dominor ZR G223
 Bkt Larkeisa G591 CD

DAM		Calv.Ease	BW	WW	YW	Milk	HPG	Stay	Maint.En.
Age	6	3	+4.2	41	72	19	7	10	+0.7
Wt	1080								
Prog.BW	77								
WR	104								
YR	101								
Cow Eff.	103								
		Marb	REA	Bfat		BWt	WR	YR	Fr.
		+.13	-.05	.01		95	105	102	med

The Epic sire line produces a lot of good cows, and the female sides of this pedigree may be even stronger. Larkeisa's dam averages 104 at weaning and 101 yearling on her calves, her maternal granddam averaged 105 and 106, and her paternal granddam averaged 105 and 105. She is calving this year for us at 13, almost always in the first two weeks. Fertility and longevity.

• Heifers •



313 1-A 100% # 1240511Tattoo: TR2A8 UT89

Birth: 2-15-08

Beckton Epic K F075
 Beckton Epic D404
 Beckton Belga D483 KR

BECKTON EPIC KM M115
 Ref. E-1 Beckton Minerva F495 CH
 Beckton Champ R A583
 Beckton Minerva CB69 JL

MR. R2R Marvel A13N3
 BFCK Cherokee Cnyn 4912
 BKT Marta 9A13 JL

TR LANA ST686
 TR Lana PT464
 TR Julian LT151
 TR Lana G760

DAM		Calv.Ease	BW	WW	YW	Milk	HPG	Stay	Maint.En.
Age	2	12	-2.2	30	63	19	8	13	+0.8
Wt	0								
Prog.BW									
WR	103								
YR	107								
Cow Eff.		Marb -.05	REA -.01	Bfat .01		BWt 68	WR 103	YR 107	Fr. med

Look at the great spread on this young heifer's birth to yearling profile. From a -2.2 BW EPD to a 64 YW is good performance. Throw in a ME in the top 16% of the breed and a 7% STAY and you have the promise of a fabulous cow.

311 1-A 100% # 1240458Tattoo: TR2A8 UT87

Birth: 2-19-08

Beckton Epic K F075
 Beckton Epic D404
 Beckton Belga D483 KR

BECKTON EPIC KM M115
 Ref. E-1 Beckton Minerva F495 CH
 Beckton Champ R A583
 Beckton Minerva CB69 JL

Beckton Julian GG B571
 BKT Julian 7526 G
 BKT Marta 9A13 JL

TR WILLOW NT336
 DMW Buckeye Nance L10
 BFCK Cherokee Cnyn 4912
 Buckeye Theresa

DAM		Calv.Ease	BW	WW	YW	Milk	HPG	Stay	Maint.En.
Age	5	10	+0.1	45	77	21	8	14	+2.2
Wt	0								
Prog.BW	83								
WR	107								
YR	104								
Cow Eff.		Marb +.05	REA +.06	Bfat .02		BWt 89	WR 116	YR 114	lar



A powerful heifer, she scores in the top 11% of the breed for calving ease, top 5% for weaning, yearling, and total maternal, top 4% for stayability, and is positive for REA and MARB.

312 1-A 100% # 1240459Tattoo: TR2A8 UT82

Birth: 2-18-08

Beckton Julian GG B571
 BKT Julian 7526 G
 BKT Marta 9A13 JL

TR JULIAN LT151
 Ref. J-11 MS Geometric 917
 BJR Yo 121
 MS Geometric

BUF Crk Hobo 1961
 BUF Crk Hobo 1413
 BUF Cr Carrie VC1174

TR BRITTNEY NT316
 Beckton Lana E828 SC
 Beckton Scamp 8954
 Beckton Lana B695 SG

DAM		Calv.Ease	BW	WW	YW	Milk	HPG	Stay	Maint.En.
Age	5	11	+0.2	38	66	15	12	14	+2.8
Wt	0								
Prog.BW	76								
WR	105								
YR	104								
Cow Eff.		Marb +.09	REA +.01	Bfat .00		BWt 91	WR 111	YR 111	lar

A powerful daughter of the rare TR JULIAN LT151, this heifer does everything right. Calving ease in the top 10%, top 25% for growth, top 9% in heifer pregnancy, top 4% in maternal calving ease, top 4% of stayability, and is positive for the carcass traits of ribeye and marbling.

314 1-A 100% # 1240468Tattoo: TR2A8 UT82

Birth: 3-12-08

Beckton Lancer T A664
 Beckton Lancer 9380
 Beckton Coca 9119 TJ

TR LANCER ST628
 Ref. L-5 MS Geometric 928
 Algebra I 769
 MS Geometric 661

Beckton Lancer T A664
 Beckton Lancer 9380
 Beckton Coca 9119 TJ

TR CEDAR PT466
 MS Geometric 917
 BJR Yo 121
 MS Geometric

DAM		Calv.Ease	BW	WW	YW	Milk	HPG	Stay	Maint.En.
Age	4	12	-1.4	35	69	11	7	9	+17.3
Wt	0								
Prog.BW	78								
WR	100								
YR	103								
Cow Eff.		Marb +.18	REA -.06	Bfat -.01		BWt 86	WR 104	YR 109	lar

A double bred LANCER daughter that brings calving ease, dynamic growth, heifer pregnancy, and stayability in a moderate package.

• Heifers •

315 **TR CEDAR UT858**
1-A 100% # 1240413Tattoo: TR2A8 UT85

Birth: 3-9-08

BFCK Cherokee Cnyn 4912 < BUF Crk Chf 824-1658
MRM 1431 8611 9109

TR RICARDO RT574
Ref. B-5 < TR Dyna LT111 < Beckton Julian GG B571
BSF Dyna JT976

BJR Make My Day 981 < BJR Easy Rider 781
BJR Tow Kana 117-710

MS GEOMETRIC 003
MS Geometric 277 < BKT Julian 7526 G
MS Geometric 962

DAM		Calv.	Ease	BW	WW	YW	Milk	HPG	Stay	Maint.En.					
Age	8	11	-2.9	25	55	12	10	12	12	+4.8					
Wt	0														
Prog.BW	79														
WR	93														
YR	98														
Cow Eff.		Marb	+0.25	REA	+0.23	Bfat	.01	BWt	83	WR	85	YR	97	Fr.	med

The only TR RICARDO RT574 daughter to be offered by Tongue River this year. She is the natural daughter of MS GEOMETRIC 003, a TR donor cow. She has Cherokee Canyon and B571 on the top of her pedigree with Make My Day 981 and JULIAN 7526 on the bottom.

317 **TR LANA UT873**
1-A 100% # 1240455Tattoo: TR2A8 UT87

Birth: 3-4-08

Loosli Cherokee Teton 316N < BFCK Cherokee Cnyn 4912
Miss LL Divide 703

BUF CRK TETON R088
Ref. B-4 < BUF Crk Hall N353 < Beckton Lancer F442 T
BUF Crk Hall 6182A

BSF Julian JT911 < Beckton Julian G717 GG
TR Lydia G750

TR LANA NT331
TR Lana G760 < Beckton Cody V E023
Beckton Lana E828 SC

DAM		Calv.	Ease	BW	WW	YW	Milk	HPG	Stay	Maint.En.					
Age	5	12	-2.8	26	49	14	11	10	-0.2						
Wt	0														
Prog.BW	73														
WR	98														
YR	99														
Cow Eff.		Marb	+0.14	REA	+0.25	Bfat	.00	BWt	70	WR	94	YR	101	Fr.	med

The LANA cow line is the foundation of the Tongue River herd, and UT873 shows why. She is in the top 20% of the breed for CED, BW, ME, HPG, MARB, and REA.

316 **TR WILLOW UT861**
1-A 100% # 1240417Tattoo: TR2A8 UT86

Birth: 2-24-08

BKT Julian 7526 G < Beckton Julian 6592
BKT Belga 6746 GS

TR JULIAN RT554
Ref. J-12 < Beckton Vernice G373 WR < Beckton Warrior T C371
Beckton Vernice D066 NM

BUF Crk Dynamics 3820 < RCN Dynamo 732
BUF Crk Primrose 3150

BUCKEYE WILMA K69
Buckeye Ida < Glacier Northern KNG656
Buckeye Vera

DAM		Calv.	Ease	BW	WW	YW	Milk	HPG	Stay	Maint.En.					
Age	8	15	-4.4	20	40	11	10	13	+1.8						
Wt	0														
Prog.BW	74														
WR	99														
YR	100														
Cow Eff.		Marb	-0.04	REA	-0.13	Bfat	-0.01	BWt	71	WR	95	YR	99	Fr.	med

A nice calving ease heifer with good stayability numbers.

318 **TR CEDAR UT852**
1-A 100% # 1240408Tattoo: TR2A8 UT85

Birth: 3-2-08

BKT Julian 7526 G < Beckton Julian 6592
BKT Belga 6746 GS

TR JULIAN RT554
Ref. J-12 < Beckton Vernice G373 WR < Beckton Warrior T C371
Beckton Vernice D066 NM

BJR Make My Day 981 < BJR Easy Rider 781
BJR Tow Kana 117-710

MS GEOMETRIC 922
MS Geometric 653 < BJR Yo 121
MS Geometric 360

DAM		Calv.	Ease	BW	WW	YW	Milk	HPG	Stay	Maint.En.					
Age	9	10	-2.6	23	48	17	9	11	+6.2						
Wt	0														
Prog.BW	77														
WR	109														
YR	108														
Cow Eff.		Marb	+0.20	REA	+0.05	Bfat	-0.01	BWt	75	WR	100	YR	99	Fr.	med

This calf is the natural daughter of MS Geometric 922 and TR JULIAN RT554, a paternal half brother to B571. The cow has been an embryo donor for Tongue River with several high dollar bulls and heifers to her credit from ET.



319 **TR WILLOW UT862**
1-A 100% # 1240415Tattoo: TR2A8 UT86

Birth: 3-11-08

BKT Julian 7526 G < Beckton Julian 6592
BKT Belga 6746 GS

TR JULIAN RT554
Ref. J-12 < Beckton Vernice G373 WR < Beckton Warrior T C371
Beckton Vernice D066 NM

DMW Canyon H09 < BUF Crk Chf 824-1658
Buckeye Pam

BUCKEYE AGNES K98
Buckeye Rosemary < JKG Chiefton L303
Buckeye Nannette

DAM		Calv.	Ease	BW	WW	YW	Milk	HPG	Stay	Maint.En.					
Age	8	12	-4.1	19	41	12	12	11	+1.9						
Wt	0														
Prog.BW	73														
WR	100														
YR	101														
Cow Eff.		Marb	+0.09	REA	-0.02	Bfat	-0.01	BWt	76	WR	100	YR	101	Fr.	med

A low birth weight Julian daughter with great maternal numbers.

• Heifers •

320 TR CEDAR UT856
1-A 100% # 1240412 Tattoo: TR2A8 UT85

Birth: 2-19-08
Beckton Julian GG B571
BKT Julian 7526 G
BKT Marta 9A13 JL

TR JULIAN LT142
Ref. J-10
TR Lana G760
Beckton Cody V E023
Beckton Lana E828 SC

Algebra I 803
BJR Make My Day 981
MS Geometric 462

MS GEOMETRIC 030
MS Geometric 153
BJR C-Chief 811
MS Geometric 726

DAM		Calv.Ease	BW	WW	YW	Milk	HPG	Stay	Maint.En.
Age	8	16	-2.8	28	44	14	13	11	+2.6
Wt	0								
Prog.BW	80								
WR	100								
YR	98								
Cow Eff.									

Marb **+1.0** REA **-1.0** Bfat **-0.01** BWt **80** WR **99** YR **94** Fr. **med**

This is the only TR JULIAN LT142 daughter in the sale. She has all the maternal traits one would expect: top 1% for calving ease, top 4% for heifer pregnancy, and top 25% for stayability.

322 BECKTON BELGA U646 JD
1-A 100% # 1259394 Tattoo: BKT8 U646

Birth: 3-31-08
TR Julian LT151
Beckton Julian GG B571
MS Geometric 917

TR JULIAN RT561
Ref. J-13
TR Dyna HT824
Buf Crk Dynamics 3820
Buf Crk Dyna 3082

Beckton Lancer T A664
Beckton Lancer 9380
Beckton Coca 9119 TJ

BECKTON BELGA K202 LN
Beckton Belga D460 KR
Beckton Kaiser FD 9253
Beckton Belga A573 SC

DAM		Calv.Ease	BW	WW	YW	Milk	HPG	Stay	Maint.En.
Age	8	17	-3.9	24	48	10	7	13	-0.3
Wt	1185								
Prog.BW	60								
WR	96								
YR	100								
Cow Eff.	92								

Marb **+0.08** REA **+1.1** Bfat **-0.01** BWt **67** WR **104** YR **100** Fr. **med**

On the sire side, Lot 322 descends directly from Julian B571, the most in-demand sire in the Red Angus breed, and on the dam side from Beckton Lancer A664, one of the breed's first great all-round carcass sires.



323 BECKTON LYDIA U012 HS
2 100% # 1258818 Tattoo: BKT8 U012

Birth: 2-15-08
Beckton Hasten P292
Beckton Sheba L644 CH

BECKTON HASTEN H S462
Ref. H-3
Beckton Lakme G128 HD
Beckton Hadrian FC E166
Beckton Lakme E373 CL

Beckton Jules L429
Beckton Julian G1 J526
Beckton Barona J591 EP

BECKTON LYDIA S840 JE
Beckton Lydia L625 WR
Beckton Warrior C C355
Beckton Lydia G059 WR

DAM		Calv.Ease	BW	WW	YW	Milk	HPG	Stay	Maint.En.
Age	2	14	-4.6	28	59	17	9	10	-0.4
Wt	855								
Prog.BW	53								
WR	108								
YR	110								
Cow Eff.	108								

Marb **+0.02** REA **+2.22** Bfat **-0.01** BWt **53** WR **108** YR **110** Fr. **med**

For performance minded cattle people, Lydia U012 gives a great set of balanced EPD's all the way across, from low Maintenance to strong Rib-eye, and has excellent performance ratios on her own.

321 BECKTON COCA U798 EP
1-A 100% # 1259462 Tattoo: BKT8 U798

Birth: 4-16-08
Beckton Epic KJ J722
Beckton Epic K F075
Beckton Lana F891 JL

BECKTON EPIC K4 N795
Ref. E-2
Beckton Sierra J789 EP
Beckton Epic D404
Beckton Sierra C157 CL

Beckton Herald FJ J776
Beckton Herald F FA20
Bkt Larkeisa D095 JL

BECKTON COCA N282 HR
Beckton Coca E881 RN
Beckton Ranger H Z095
Beckton Coca B112 CB

DAM		Calv.Ease	BW	WW	YW	Milk	HPG	Stay	Maint.En.
Age	5	9	+0.4	40	72	13	10	10	+1.4
Wt	1170								
Prog.BW	69								
WR	104								
YR	101								
Cow Eff.	98								

Marb **+1.0** REA **+1.0** Bfat **.01** BWt **76** WR **112** YR **106** Fr. **med**

Coca U798 is +8 pounds higher than breed average for Weaning Weight EPD, +16 pounds higher for Yearling Weight, but is significantly lower for Maintenance EPD than breed average. All gain, no pain.

324 BECKTON LANA U611 NB
2 100% # 1259371 Tattoo: BKT8 U611

Birth: 3-28-08
Beckton Nebula M045
Beckton Neptune R2 K065
Beckton Belga K285 JL

BECKTON NEBULA E P084
Ref. N-2
BKT Pine Marie M119 EP
Beckton Epic K F075
Bkt Pine Marie D126 JL

Beckton Herald K B244
Leachman Heavenly 8141
Beckton Larkaba Z581 KR

BECKTON LANA G400 HR
Beckton Lana D824 NP
Beckton Neptune RT Z305
Beckton Lana Z315 JL

DAM		Calv.Ease	BW	WW	YW	Milk	HPG	Stay	Maint.En.
Age	11	11	-1.8	29	54	12	9	13	-5.6
Wt	1195								
Prog.BW	79								
WR	109								
YR	105								
Cow Eff.	93								

Marb **+1.16** REA **+0.08** Bfat **.01** BWt **78** WR **106** YR **109** Fr. **med**

The Beckton herd is known for low Maintenance EPD, and here is one of the lowest. All of the other EPD's and performance data is good also. And look at the performance of Lana's dam, now calving for us at 12 years of age.

• Heifers •

325 **BSF CHAMPALA U362 NB**
2 99% # 1259245 Tattoo: BSF8 U362

Birth: 3-18-08

Beckton Neptune R2 K065
Beckton Neptune RR B284
Beckton Lana C735 TP

BECKTON NEBULA M045
Ref. N-1
Beckton Belga K285 JL
Beckton Julian GG B571
Beckton Belga G493 HR

Beckton Champ R3 H338
Beckton Champ RK E121
Beckton Encino C644 ZN

BSF CHAMPALA P257
Beckton Neptune RT Z305
BSF Regus H196
BSF Red E036

DAM		Calv.Ease	BW	WW	YW	Milk	HPG	Stay	Maint.En.
Age	4	14	-3.4	25	56	7	9	12	-2.5
Wt	1140								
Prog.BW	57								
WR	88								
YR	100								
Cow Eff.	81								

Marb	+0.09	REA	+1.16	Bfat	.00	BWt	70	WR	91	YR	104	Fr.	med
------	-------	-----	-------	------	-----	-----	----	----	----	----	-----	-----	-----

An own daughter of Nebula M045. Nebula has become the #1 sire in the breed for low maintenance, calving ease and efficiency, combined with other traits of value. He has produced wonderful daughters, but we are using his sons and grandsons heavily, and own daughters from our herd are rare.

327 **BKB HELENA U534 JL**
1-B 87% # 1259161 Tattoo: BKB8 U534

Birth: 3-24-08

Beckton Julian 7526G
Beckton Julian 6592
Bkt Belga 6746 GS

BECKTON JULIAN GJ P535
Ref. J-5
Beckton Mona D086 JL
Beckton Julian GV Z693
Beckton Mona 9356 KR

BSF Hustler C1 L004
Beckton Hustler CN J102
BSF Regus J475

BSF HELENA N098 HU
BRU Red LC54
Beckton Cody C401

DAM		Calv.Ease	BW	WW	YW	Milk	HPG	Stay	Maint.En.
Age	5	12	-3.6	31	56	10	13	11	+0.3
Wt	1110								
Prog.BW	77								
WR	112								
YR	106								
Cow Eff.	105								

Marb	+0.04	REA	+0.23	Bfat	.00	BWt	66	WR	110	YR	104	Fr.	med
------	-------	-----	-------	------	-----	-----	----	----	-----	----	-----	-----	-----

Helena's five year old dam, Helena N098, has put up some of the highest performance in our herd. Her calves have averaged 112 ratio at weaning and 106 at yearling.



328 **BECKTON ENCINO U070 JC**
1-A 100% # 1258895 Tattoo: WF8 U070

Birth: 2-27-08

Beckton Justice CH M056
Beckton Ruth K802 HD

BECKTON JUSTICE C1 R483
Ref. J-7
Beckton Tamara J124 HR
Beckton Herald F FA20
Beckton Tamara F183 CT

Beckton Champ R3 H338
Beckton Champ RK E121
Beckton Encino C644 ZN

BECKTON ENCINO L922 CH
Beckton Encino G341 NP
Beckton Neptune RR B284
Bkt Encino 8459 TJ

DAM		Calv.Ease	BW	WW	YW	Milk	HPG	Stay	Maint.En.
Age	7	14	-3.8	28	56	16	9	11	-0.5
Wt	1115								
Prog.BW	64								
WR	102								
YR	103								
Cow Eff.	94								

Marb	+0.02	REA	+0.02	Bfat	-0.01	BWt	70	WR	102	YR	98	Fr.	med
------	-------	-----	-------	------	-------	-----	----	----	-----	----	----	-----	-----

A balanced set of EPD's with nice low Maintenance, and out of a 7 year old dam above average in all of her progeny averages.

326 **BECKTON CHRISTY U308 JL**
1-A 100% # 1258907 Tattoo: WF8 U308

Birth: 3-16-08

Beckton Julian GG B571
Beckton Julian 7526G
Bkt Marta 9A13 JL

BECKTON JULIAN G3 P608
Ref. J-6
Bkt Suffeina A828 DM
Beckton Dominor 9455
Bkt Suffeina 9493 TT

Beckton Warrior T C371
JKG Chiefton L303
Beckton Tamla A671 TR

BECKTON CHRISTY M362 WR
Beckton Christy C306 JL
Beckton Julian 7526G
Beckton Christy Z264 NP

DAM		Calv.Ease	BW	WW	YW	Milk	HPG	Stay	Maint.En.
Age	6	18	-6.6	18	45	12	12	14	-4.9
Wt	1180								
Prog.BW	62								
WR	98								
YR	99								
Cow Eff.	92								

Marb	+0.13	REA	+0.12	Bfat	-0.01	BWt	54	WR	103	YR	102	Fr.	med
------	-------	-----	-------	------	-------	-----	----	----	-----	----	-----	-----	-----

As strong an overall performance heifer as there is in the sale. Close to the lowest Maintenance Energy EPD, highest Calving Ease EPD and strongest overall carcass Marbling and Rib-eye EPD's.

329 **BECKTON SIERRA U479 LN**
1-A 100% # 1258995 Tattoo: WF8 U479

Birth: 3-22-08

Beckton Lancer TA K644
Beckton Lancer T A664
Beckton Tamara B570 JL

BECKTON LANCER T9 N586
Ref. L-2
BKT Larkeisa H232 SC
Beckton Scamp TR FB22
Bkt Larkeisa F828 JL

Beckton Warrior TD L493
Beckton Warrior T C371
Bkt Suffeina A828 DM

BECKTON SIERRA P625 WR
Beckton Sierra L681 HR
Beckton Herald FV J537
Beckton Sierra J330 LN

DAM		Calv.Ease	BW	WW	YW	Milk	HPG	Stay	Maint.En.
Age	4	12	-1.4	29	57	12	10	10	+4.0
Wt	1310								
Prog.BW	71								
WR	104								
YR	106								
Cow Eff.	84								

Marb	+0.06	REA	+0.04	Bfat	-0.02	BWt	70	WR	107	YR	106	Fr.	med
------	-------	-----	-------	------	-------	-----	----	----	-----	----	-----	-----	-----

For the sale we try to find as many heifers as possible out of great dams, because we want our customers to get great production females. Sierra's dam is another Beckton cow well above average with her progeny performance.

• Heifers •

330 **BECKTON MINERVA U356 EP**
1-A 100% # 1259008 Tattoo: WF8 U356

Birth: 3-18-08

Beckton Epic K F075
Beckton Epic D404
Beckton Belga D483 KR

BECKTON EPIC KM M115
Ref. E-1
Beckton Minerva F495 CH
Beckton Champ R A583
Beckton Minerva CB69 JL

Beckton Julian G1 J526
Beckton Julian GG B571
Beckton Annie F743 LN

BECKTON MINERVA P915 JL
Beckton Minerva K347 JC
Beckton Justice G302
Beckton Minerva F218 JL

DAM		Calv.Ease	BW	WW	YW	Milk	HPG	Stay	Maint.En.
Age	4	14	-2.5	35	66	13	7	14	-3.3
Wt	905	Marb	+0.06	REA	-0.06	Bfat	.01	BWt	65
Prog.BW	57	WR	93	YR	98	Fr.	99	sma	
WR	93								
YR	98								
Cow Eff.	106								

Epic produces nice feminine daughters like Lot 330, and they can stay with you a long time--look at the Stayability EPD of +14. Look also at the growth of +66 and the very low Maintenance EPD of -3.

332 **TR CHRISTY UT880**
1-A 100% # 1240495 Tattoo: TR2A8 UT88

Birth: 4-1-08

Beckton Lancer T A664
Beckton Lancer 9380
Beckton Coca 9119 TJ

TR LANCER ST628
Ref. L-5
MS Geometric 928
Algebra I 769
MS Geometric 661

Beckton Epic K J722
Beckton Lana F891 JL
Beckton Julian J153 G
Beckton Christy D409 NM

TR CHRISTY RT528
Beckton Christy L543 JL

DAM		Calv.Ease	BW	WW	YW	Milk	HPG	Stay	Maint.En.
Age	3	11	-1.4	32	63	10	8	11	+2.6
Wt	0	Marb	+0.00	REA	+0.00	Bfat	.00	BWt	80
Prog.BW	68	WR	87	YR	95	Fr.	102	med	
WR	87								
YR	95								
Cow Eff.									

A nicely balanced heifer with low birth weight, good growth, good ME and STA numbers.

331 **TR EOLA UT890**
1-A 100% # 1240499 Tattoo: TR2A8 UT89

Birth: 3-10-08

Beckton Julian GG B571
BKT Julian 7526 G
BKT Marta 9A13 JL

TR JULIAN ST630
Ref. J-14
MS Geometric 003
BJR Make My Day 981
MS Geometric 277

MR. R2R Marvel A13N3
BFCK Cherokee Cnyn 4912
BKT Marta 9A13 JL

TR EOLA ST680
TR Eola NT301
Beckton Clifftop T C075
Beckton Eola E567 JL

DAM		Calv.Ease	BW	WW	YW	Milk	HPG	Stay	Maint.En.
Age	2	12	-0.5	27	52	11	13	18	-0.9
Wt	0	Marb	+0.08	REA	+0.16	Bfat	.01	BWt	82
Prog.BW	77	WR	101	YR	100	Fr.	97	102	med
WR	97								
YR	102								
Cow Eff.									

A first calf heifer produced this great young cow. She comes from a wonderful cow line and a young Julian sire. She scores in the top 10% of the breed for CED, ME, HPG, STAY, and is positive for both MARB and REA.

333 **TR MINOLA UT866**
1-A 100% # 1240444 Tattoo: TR2A8 UT86

Birth: 3-17-08

Beckton Julian GG B571
BKT Julian 7526 G
BKT Marta 9A13 JL

TR JULIAN ST630
Ref. J-14
MS Geometric 003
BJR Make My Day 981
MS Geometric 277

BUF Crk Iowa 2886
Schuler Iowa 527-615
BUF Crk Marigold1230

BUF CRK MINOLA L344
BUF Crk Minola 4947
BUF Crk Vaquero 2978
BUF Crk Minola 2224

DAM		Calv.Ease	BW	WW	YW	Milk	HPG	Stay	Maint.En.
Age	7	17	-4.7	23	43	12	10	13	.0
Wt	0	Marb	+0.12	REA	-0.04	Bfat	.01	BWt	68
Prog.BW	77	WR	101	YR	100	Fr.	98	98	med
WR	101								
YR	100								
Cow Eff.									

A Julian daughter with top of the breed maternal numbers.



334 **TR WILLOW UT879**
1-A 100% # 1240486 Tattoo: TR2A8 UT87

Birth: 3-4-08

Beckton Lancer T A664
Beckton Lancer 9380
Beckton Coca 9119 TJ

TR LANCER ST628
Ref. L-5
MS Geometric 928
Algebra I 769
MS Geometric 661

TR Julian LT151
Beckton Julian GG B571
MS Geometric 917

TR WILLOW RT518
Buckeye Pam K48
BUF Crk Dynamics 3820
Buckeye Alberta

DAM		Calv.Ease	BW	WW	YW	Milk	HPG	Stay	Maint.En.
Age	3	20	-7.7	24	51	14	8	11	+10.3
Wt	0	Marb	+0.09	REA	+0.03	Bfat	-0.01	BWt	46
Prog.BW	75	WR	106	YR	101	Fr.	102	97	med
WR	106								
YR	101								
Cow Eff.									

Low, low birth weight with Lancer on the top side and TR JULIAN LT151 on the bottom side, with a good stayability number.

• Heifers •

335 TR ANASCO UT884
1-A 100% # 1240496Tattoo: TR2A8 UT88

Birth: 3-19-08

BKT Julian 7526 G
Beckton Julian 6592
BKT Belga 6746 GS

TR JULIAN RT554
Ref. J-12
Beckton Vernice G373 WR
Beckton Warrior T C371
Beckton Vernice D066 NM

MR R2 Mountain Man 570N
Glacier Mountaineer 160
BUF Crk Carrie 5705

R2 ANASCO 092R
BUF Crk Anasco M092
BUF Crk Dynaband 5612
BUF Crk Anasco 5843

DAM		Calv.Ease	BW	WW	YW	Milk	HPG	Stay	Maint.En.
Age	3	11	-1.8	25	46	12	13	12	-0.9
Wt	0	Marb	+0.08	REA	+0.01	Bfat	.00	BWt	78
Prog.BW	71	WR	98	YR	100	Fr.	sma		
WR	98								
YR	100								
Cow Eff.									

337 TR DYNA UT868
1-A 100% # 1240425Tattoo: TR2A8 UT86

Birth: 3-25-08

Beckton Lancer T A664
Beckton Lancer 9380
Beckton Coca 9119 TJ

TR LANCER ST628
Ref. L-5
MS Geometric 928
Algebra I 769
MS Geometric 661

Beckton Lancer F134 TS
Beckton Lancer TS D390
Beckton Tara D565 CB

TR DYNA LT118
TR Dyna HT824
BUF Crk Dynamics 3820
BUF Crk Dyna 3082

DAM		Calv.Ease	BW	WW	YW	Milk	HPG	Stay	Maint.En.
Age	7	15	-5.0	25	48	12	7	11	+3.5
Wt	0	Marb	+0.12	REA	-0.12	Bfat	-0.01	BWt	70
Prog.BW	81	WR	99	YR	101	Fr.	sma		
WR	99								
YR	101								
Cow Eff.									

This attractive heifer is strongly positive for all the maternal traits we like to see: calving ease, low maintenance, heifer pregnancy, and stayability.

Here is another Julian daughter with good EPDs for calving ease, stayability, and marbling.



338 TR EOLA UT894
1-A 100% # 1240504Tattoo: TR2A8 UT89

Birth: 3-9-08

BFCK Cherokee Cnyn 4912
BUF Crk Chf 824-1658
MRM 1431 8611 9109

TR RICARDO RT574
Ref. B-5
TR Dyna LT111
Beckton Julian GG B571
BSF Dyna JT976

TR Julian LT151
Beckton Julian GG B571
MS Geometric 917

TR EOLA ST688
TR Eola G740
Beckton Hadrian FC E166
Beckton Eola E192 CL

DAM		Calv.Ease	BW	WW	YW	Milk	HPG	Stay	Maint.En.
Age	2	16	-5.1	22	50	13	11	15	+0.3
Wt	0	Marb	+0.10	REA	+0.42	Bfat	.00	BWt	61
Prog.BW	86	WR	86	YR	94	Fr.	sma		
WR	86								
YR	94								
Cow Eff.									

336 TR LYDIA UT870
1-A 100% # 1240453Tattoo: TR2A8 UT87

Birth: 4-13-08

Beckton Lancer T A664
Beckton Lancer 9380
Beckton Coca 9119 TJ

TR LANCER ST628
Ref. L-5
MS Geometric 928
Algebra I 769
MS Geometric 661

Beckton Lancer F134 TS
Beckton Lancer TS D390
Beckton Tara D565 CB

TR LYDIA MT244
Beckton Lydia E251 CL
Beckton Clipper ER C360
Beckton Lydia C180 CF

DAM		Calv.Ease	BW	WW	YW	Milk	HPG	Stay	Maint.En.
Age	6	14	-3.1	31	57	16	8	10	+6.6
Wt	0	Marb	+0.16	REA	-0.09	Bfat	-0.01	BWt	74
Prog.BW	78	WR	110	YR	105	Fr.	sma		
WR	110								
YR	105								
Cow Eff.									

A double bred moderate Lancer daughter.

339 TR LANA UT883
1-A 100% # 1240492Tattoo: TR2A8 UT88

Birth: 3-7-08

BFCK Cherokee Cnyn 4912
BUF Crk Chf 824-1658
MRM 1431 8611 9109

MR. R2R MARVEL A13N3
Ref.
BKT Marta 9A13 JL
BKT Julian 7526 G
BKT Marta 6498 XM

Beckton Julius M213
Beckton Lancer F134 TS
Beckton Lancer TS D390
Beckton Tara D565 CB

TR LANA RT547
TR Lana NT331
BSF Julian JT911
TR Lana G760

DAM		Calv.Ease	BW	WW	YW	Milk	HPG	Stay	Maint.En.
Age	3	11	+0.1	28	43	15	14	14	-3.4
Wt	0	Marb	+0.03	REA	+0.20	Bfat	.01	BWt	85
Prog.BW	83	WR	103	YR	100	Fr.	sma		
WR	103								
YR	100								
Cow Eff.									

If good maternal numbers are what you are looking for then it doesn't get much better than UT883. She scores in the top 8% for CED, 3% for ME, 2% for HPG, 5% for STAY, and is positive for MARB and REA.

• Heifers •



342 **BSF BUFFIE U287 EP**
1-B 99% # 1259326 Tattoo: BSF8 U287

Birth: 3-15-08

Beckton Epic KM M115
Beckton Epic K F075
Beckton Minerva F495 CH

BECKTON EPIC K6 S569
Ref. E-5
Beckton Sierra N703 LM
Beckton Laramie L044
Beckton Sierra L887 LN
Beckton Julian GG B571
Bkt Vernice 9733 PC

Beckton Justice G302
Beckton Copper JT G095
BSF Buffie N856 CO
BSF Regus F207

DAM		Calv.Ease	BW	WW	YW	Milk	HPG	Stay	Maint.En.
Age	2	10	-1.5	36	67	16	8	13	+2.0
Wt	945								
Prog.BW	61								
WR	99								
YR	99								
Cow Eff.	94								
		Marb	+0.09	REA	+1.0	Bfat	.01	BWt	61
				WR	99	YR	99	Fr.	sma

A smaller heifer out of a 2 year old dam, we really like Buffie's pedigree. Her sire comes from Epic F075 and Epic M115, and her dam from the great Julian B571.

340 **TR NELL UT875**
1-A 100% # 1240476 Tattoo: TR2A8 UT87

Birth: 4-8-08

Beckton Julian GG B571
BKT Julian 7526 G
BKT Marta 9A13 JL

TR JULIAN ST630
Ref. J-14
MS Geometric 003
BJR Make My Day 981
MS Geometric 277

BUF Crk Romeo L081
Beckton Julian GG B571
BUF Crk Primrose 5679

BUF CRK NELL P115
BUF Crk Nell L451
BUF Crk Dynamics 3820
BUF Crk Nell 1439

DAM		Calv.Ease	BW	WW	YW	Milk	HPG	Stay	Maint.En.
Age	4	16	-5.0	21	47	13	11	15	+1.3
Wt	0								
Prog.BW	68								
WR	96								
YR	98								
Cow Eff.		Marb	+1.13	REA	+1.0	Bfat	.01	BWt	67
				WR	95	YR	96	Fr.	med

A top double bred JULIAN daughter, UT875 is in the top 20% of the breed for CE, BW, ME, HPG, CEM, STAY, and is strongly positive for MARB and REA. It doesn't get much better than that.

343 **BECKTON COCA U740 JT**
1-A 100% # 1259602 Tattoo: BKT8 U740

Birth: 4-8-08

TR Julian LT151
Beckton Julian GG B571
MS Geometric 917

BECKTON JET L P491
Ref. J-4
Beckton Minerva L278 LN
Beckton Lancer TS D390
Beckton Minerva F495 CH
Beckton Cody K G701
Beckton Tamara J124 HR

Beckton Cody KH M390
Beckton Lancer F442 T
Beckton Coca M175 LN
Beckton Coca K295 CO

DAM		Calv.Ease	BW	WW	YW	Milk	HPG	Stay	Maint.En.
Age	3	16	-4.9	22	48	18	8	14	+0.9
Wt	965								
Prog.BW	51								
WR	103								
YR	101								
Cow Eff.	102								
		Marb	+1.15	REA	+0.04	Bfat	.00	BWt	60
				WR	107	YR	102	Fr.	sma

A feminine heifer with balanced EPD's and high Milk, and very moderate size. Like so many of the heifers we chose for the sale, she is out of an above-average dam.

341 **BSF HUSTELLE U251 NM**
1-B 99% # 1259244 Tattoo: BSF8 U251

Birth: 3-14-08

Beckton Nomad 7496
Beckton Neva 5562
Bkt Bolt Tamrck 3913

BECKTON NOMAD T 9A14
Ref.
Beckton Lana 7152 TJ
Beckton Trojan 5253
Bkt Signal Lana 5599

Beckton Hustler C2 L079
Beckton Hustler CN J102
Beckton Barmaid J012 CO

BSF HUSTLE P246
BSF Regus E323
Beckton Hadrian A100
BSF Regus 8183-2

DAM		Calv.Ease	BW	WW	YW	Milk	HPG	Stay	Maint.En.
Age	4	13	-4.2	17	32	5	11	10	-4.1
Wt	1065								
Prog.BW	70								
WR	103								
YR	102								
Cow Eff.	93								
		Marb	+0.01	REA	-0.04	Bfat	-0.02	BWt	65
				WR	95	YR	95	Fr.	sma

These last few heifers in the sale are out of very young dams, but take a look at this dam's performance, and why we think U251 has excellent potential.

344 **BECKTON ANGEL U763 NB**
1-A 100% # 1259027 Tattoo: WF8 U763

Birth: 4-12-08

Beckton Neptune R2 K065
Beckton Neptune RR B284
Beckton Lana C735 TP

BECKTON NEBULA M045
Ref. N-1
Beckton Belga K285 JL
Beckton Julian GG B571
Beckton Belga G493 HR
Beckton Julian G1 J526
Beckton Serena D760 KR

Beckton Juno N493
Beckton Herald F2 L832
Beckton Angel N115 HR
Beckton Angel L385 EP

DAM		Calv.Ease	BW	WW	YW	Milk	HPG	Stay	Maint.En.
Age	3	17	-4.9	30	54	9	7	13	+0.3
Wt	1100								
Prog.BW	47								
WR	105								
YR	99								
Cow Eff.	92								
		Marb	+0.06	REA	+0.05	Bfat	.00	BWt	62
				WR	105	YR	99	Fr.	sma

The sale concludes with an angel, or at least a very feminine Angel heifer and another own daughter of Beckton Nebula M045. You will hear much more about Nebula in the future, because ABS is taking him under lease.

Semen Available

Bull Name	Reg.No.	Calving Ease	BW	WW	YW	Milk	HPG	Stay	Maint. Energy	Marb	REA	Bfat	Price
		Acc.	Acc.	Acc.	Acc.	Acc.	Acc.	Acc.	Acc.	Acc.	Acc.	Acc.	
Beckton Lancer T A664	358389	15	-3.0	28	59	6	-1	14	7	.25	.01	-.01	\$18/60
		.89	.92	.90	.90	.89	.80	.77	.62	.74	.72	.60	
Beckton Clifftop T C075	421391	14	-5.7	20	44	12	10	15	-3	.01	.20	-.02	\$18/60
		.76	.82	.79	.79	.76	.62	.65	.57	.63	.59	.46	
Bkt Clifftop TV G672	577071	10	-2.6	16	37	9	12	11	-6	.10	.09	-.02	\$18/60
		.59	.75	.69	.67	.59	.33	.29	.45	.53	.49	.36	
Beckton Jules L429	793522	16	-6.7	20	39	17	5	12	0	-.02	.14	.01	\$18/60
		.58	.78	.71	.68	.57	.28	.01	.46	.46	.42	.26	
Beckton Nebula M045	854775	18	-6.3	29	62	6	10	14	-7	.15	.24	.00	★★★
		.72	.84	.80	.78	.72	.39	.18	.54	.51	.46	.29	
Beckton Cody KH M390	854892	13	-4.5	26	57	13	9	12	-4	.01	-.07	.02	\$18/60
		.47	.76	.67	.62	.45	.01	.01	.34	.44	.41	.27	
Beckton Cherokee N N479	916601	14	-5.2	31	46	19	11	10	-3	.14	.22	.02	\$18/60
		.51	.76	.68	.63	.50	.32	.28	.40	.48	.45	.32	
Beckton Juno N493	916615	17	-5.8	30	43	10	6	13	2	-.02	-.03	-.01	\$18/60
		.55	.74	.66	.64	.54	.33	.22	.44	.43	.40	.27	
Beckton Warrior N645 T1	916767	5	-0.2	40	78	8	9	10	-1	-.01	.01	.01	\$18/60
		.31	.66	.54	.45	.27	.15	.01	.16	.36	.34	.23	
Beckton Epic K4 N795	916917	8	-0.3	35	85	10	8	10	0	.25	.19	.01	\$18/60
		.63	.80	.74	.71	.62	.30	.15	.44	.47	.43	.26	
Beckton Nebula L P093	978419	14	-2.8	36	71	3	8	15	-4	.13	.37	-.01	\$18/60
		.40	.77	.67	.62	.37	.01	.01	.27	.44	.40	.24	
Beckton Jet L P491	978816	19	-7.7	13	37	18	8	16	2	.23	.12	.00	\$18/60
		.57	.72	.66	.63	.56	.01	.23	.43	.38	.35	.24	
Beckton Julian GJ P535	978860	16	-5.2	26	57	1	15	16	-2	.14	.16	.01	\$18/60
		.46	.71	.62	.56	.44	.22	.28	.27	.41	.38	.28	
Beckton Julian G3 P608	978932	19	-6.3	13	39	12	13	17	-5	.20	.21	.01	\$18/60
		.53	.77	.70	.65	.51	.23	.29	.40	.47	.45	.35	
Beckton Julian G4 P627	978951	16	-3.1	24	43	12	15	17	-9	.17	.24	.01	\$18/60
		.41	.70	.61	.58	.39	.13	.20	.29	.47	.44	.31	
Beckton Nebula P P707	979031	16	-4.9	37	71	15	8	13	-8	.18	.13	.01	\$18/60
		.50	.68	.61	.58	.49	.15	.01	.37	.34	.31	.21	
Beckton Epic R350 K	1042088	11	-3.7	25	54	17	11	11	1	.14	.09	.01	\$18/60
		.23	.26	.25	.25	.25	.19	.17	.18	.01	.01	.01	
Beckton HalfmannHustler R588	1042326	12	-4.5	32	67	11	7	11	5	-.11	-.04	-.02	\$18/60
		.21	.36	.28	.29	.23	.16	.01	.16	.30	.28	.22	

Reference Sires

B-1 BECKTON CHEROKEE N N479

1-A 100% # 916601 Tattoo: WF3 N479

Birth: 3-23-03

BFCK CHEROKEE CNYN 4912
Ref. B

BECKTON DINAH C440 NM
Beckton Nomad K 9949
Beckton Dinah Z610 JL

BUF CRK Chief 092-824
BUF CRK Carrie VC473
BUF CRK CHEROKEE 1431

Beckton Nomad 7496
Bkt Signal Eola 5475
Beckton Julian 7526G
Beckton Dinah 7277SB

Calv.Ease	BW	WW	YW	Milk	HPG	Stay	Maint.En.
14	-5.2	31	46	19	11	10	-2.7
(.51)	(.76)	(.68)	(.63)	(.50)	(.32)	(.28)	(.40)

Marb **+14** (.48) REA **+22** (.45) Bfat **+02** (.32)

DAM	
Age	10
Wt	1090
Wean Pct.	58%
Cow Eff.	123

BWt	WWt	WR	ADG	YWt	YR	Scr.	Fr.
71	634	109	3	1086	104	38	5.0

★★★★★ for Low Maintenance, Marbling, Rib-eye area, High Cow Efficiency, Calving Ease.

B-4 BUF CRK TETON R088

1-A 100% # 1050453 Tattoo: BUF5 RT08

Birth: 5-13-05

LOOSLI CHEROKEE TETON 316N
Ref.

BUF CRK HALL N353
Beckton Lancer F442 T
Buf Crk Hall 6182A

Buf Crk Chf 824-1658
MRM 1431 8611 9109

Glacier Divide 310
Blue Ridge Suffeina
Beckton Lancer T A664
BKT Suffeina A828 DM
Buf Crk Chf 824-1658
Buf Crk Hall 662

Calv.Ease	BW	WW	YW	Milk	HPG	Stay	Maint.En.
7	-0.5	32	48	17	10	9	-7.6
(.27)	(.57)	(.44)	(.39)	(.24)	(.01)	(.01)	(.11)

Marb **+24** (.31) REA **+36** (.30) Bfat **+00** (.24)

DAM	
Age	2
Wt	
Wean Pct.	%
Cow Eff.	

BWt	WWt	WR	ADG	YWt	YR	Scr.	Fr.
80	655	121	3	1146	105	38	5.5

★★★★★ for Low Maintenance, Marbling, Rib-eye area, Calving Ease.

B-2 BECKTON CLIFFTOP T3 N800

1-A 100% # 916922 Tattoo: BKT3 N800

Birth: 4-19-03

BKT CLIFFTOP TV G672
Ref. B

BECKTON LANA J384 CD
Beckton Cody K G701
Beckton Lana G514 CD

BJR Topper 5241
Beckton Barmaid A761 TR

Beckton Vegas 9433
Bkt Birdie 8967 JL
Beckton Cody C401
Beckton Christy B007 KR
Beckton Cody C401
Beckton Lana 9610 TP

Calv.Ease	BW	WW	YW	Milk	HPG	Stay	Maint.En.
11	-1.7	22	50	12	9	8	+1.7
(.58)	(.79)	(.72)	(.68)	(.56)	(.32)	(.14)	(.42)

Marb **+34** (.48) REA **-02** (.44) Bfat **+00** (.28)

DAM	
Age	4
Wt	1125
Wean Pct.	50%
Cow Eff.	105

BWt	WWt	WR	ADG	YWt	YR	Scr.	Fr.
84	590	101	4	1102	104	38	5.5

★★★★★ for Low Maintenance, Marbling, Calving Ease.



TR Ricardo RT574

B-3 BKT CLIFFTOP TP R288

1-A 100% # 1042026 Tattoo: WF5 R288

Birth: 3-14-05

BECKTON CLIFFTOP T C075
Ref. B

BECKTON CHRISTY K209 CO
Beckton Copper JT G095
Beckton Christy A111 VQ

Bieber Topper 2476
BJR Lakina 002-0142

Beckton Tartan 8148
Bkt Barmaid 8925 KR
Beckton Copper J E616
Beckton Ruth E549 TP
Beckton Vanquish 9977
Bkt Christy 9A01 CL

Calv.Ease	BW	WW	YW	Milk	HPG	Stay	Maint.En.
14	-5.3	15	40	17	8	12	-3.2
(.31)	(.71)	(.59)	(.51)	(.26)	(.12)	(.20)	(.16)

Marb **+03** (.39) REA **+16** (.36) Bfat **+00** (.25)

DAM	
Age	5
Wt	1065
Wean Pct.	56%
Cow Eff.	117

BWt	WWt	WR	ADG	YWt	YR	Scr.	Fr.
73	594	107	4	1163	107	38	5.0

★★★★★ for Low Maintenance, Gainability, Rib-eye area, High Cow Efficiency, Calving Ease.

B-5 TR RICARDO RT574

1-A 100% # 1045620 Tattoo: TR2A5 RT5

Birth: 2-21-05

BFCK CHEROKEE CNYN 4912
Ref.

TR DYNA LT111
Beckton Julian GG B571
BSF Dyna JT976

Buf Crk Chief092-824
Bflo Crk Carie VC473

Buf Crk Cherokee1431
MRM 8454 8219 8611
BKT Julian 7526 G
BKT Marta 9A13 JL
TR Lancer G010
Buf Crk Dyna 3082

Calv.Ease	BW	WW	YW	Milk	HPG	Stay	Maint.En.
16	-4.4	31	55	16	11	15	-2.4
(.33)	(.75)	(.57)	(.50)	(.28)	(.13)	(.20)	(.17)

Marb **+14** (.44) REA **+52** (.41) Bfat **+00** (.31)

DAM	
Age	4
Wt	NA
Wean Pct.	NA%
Cow Eff.	NA

BWt	WWt	WR	ADG	YWt	YR	Scr.	Fr.
69	647	101	3	1186	102	36	5.0

★★★★★ for Low Maintenance, Marbling, Rib-eye area, Calving Ease, Stayability.

• Reference Sires •

C-1 **BECKTON CODY K1 P014**
1-A 100% # 978340 Tattoo: WF4 P014

Birth: 2-14-04
 Beckton Cody K G701
BECKTON CODY KH M390
 Ref. C
 Beckton Tamara J124 HR
 Beckton Cody C401
 Beckton Christy B007 KR
 Beckton Herald F FA20
 Beckton Tamara F183 CT
 JKG Chiefton L303
 Beckton Tamla A671 TR
 Beckton Lancer T A664
 Beckton Rose A624 BF
BECKTON ROSE M126 WR
 Beckton Warrior T C371
 Beckton Rose D741 LN

DAM		Calv.Ease	BW	WW	YW	Milk	HPG	Stay	Maint.En.
Age	2	14	-4.0	21	57	17	6	8	+4.2
Wt	915	(.45)	(.69)	(.60)	(.55)	(.43)	(.15)	(.01)	(.31)
Wean Pct.	55%	Marb -0.04 (.36)		REA +1.18 (.33)		Bfat -0.01 (.22)			
Cow Eff.	116	BWt	WWt	WR	ADG	YWt	YR	Scr.	Fr.
		62	581	108	4	1170	119	33	5.0

★★★★★ for Gainability, Rib-eye area, High Cow Efficiency, Calving Ease.

E-1 **BECKTON EPIC KM M115**
1-A 100% # 854797 Tattoo: BKT2 M115

Birth: 3-5-02
 Beckton Epic D404
BECKTON EPIC K F075
 Ref. E
 Beckton Belga D483 KR
 Beckton Saga KJ B702
 Beckton Kuruba B508 PC
 Beckton Kaiser FD 9253
 Beckton Belga A036 MB
 Lchmn Mldd Hvywt2463
 Beckton Eola 8600 RR
BECKTON MINERVA F495 CH
 Beckton Champ R A583
 Beckton Minerva CB69 JL
 Beckton Julian GN 9A45
 Bkt Minerva 7016 TJ

DAM		Calv.Ease	BW	WW	YW	Milk	HPG	Stay	Maint.En.
Age	6	8	-0.9	41	85	22	3	10	+5.5
Wt	1125	(.69)	(.83)	(.78)	(.76)	(.69)	(.36)	(.27)	(.51)
Wean Pct.	53%	Marb +0.06 (.51)		REA -0.15 (.46)		Bfat +0.02 (.29)			
Cow Eff.	112	BWt	WWt	WR	ADG	YWt	YR	Scr.	Fr.
		74	596	103	4	1193	113	38	6.0

★★★★★ for Growth, Calving Ease.

C-2 **BECKTON CODY K2 R168**
1-A 100% # 1041906 Tattoo: WF5 R168

Birth: 3-6-05
 Beckton Cody K G701
BECKTON CODY KH M390
 Ref. C
 Beckton Tamara J124 HR
 Beckton Vegas SV H078
BECKTON TAMARA K249 VG
 Beckton Tamara HA38 WR
 Beckton Cody C401
 Beckton Christy B007 KR
 Beckton Herald F FA20
 Beckton Tamara F183 CT
 Beckton Vegas S F382
 Beckton Larkaba F252 VG
 Beckton Warrior CC E292
 Beckton Tamara Z909 SN

DAM		Calv.Ease	BW	WW	YW	Milk	HPG	Stay	Maint.En.
Age	5	13	-3.1	34	72	19	8	8	+5.0
Wt	1220	(.29)	(.65)	(.54)	(.48)	(.25)	(.01)	(.01)	(.14)
Wean Pct.	61%	Marb -0.02 (.38)		REA +1.11 (.34)		Bfat +0.01 (.21)			
Cow Eff.	129	BWt	WWt	WR	ADG	YWt	YR	Scr.	Fr.
		76	745	116	4	1285	112	39	6.0

★★★★★ for Growth, Gainability, High Cow Efficiency, Calving Ease.



Beckton Epic K4 N795

C-3 **BECKTON COBALT S029**
1-A 100% # 1118492 Tattoo: WF6 S029

Birth: 2-11-06
 Beckton Cody KH M390
BECKTON CODY K1 P014
 Ref. C
 Beckton Rose M126 WR
 Beckton Julio L233
BECKTON MARTA P633 JO
 Beckton Marta C314 JL
 Beckton Cody K G701
 Beckton Tamara J124 HR
 Beckton Warrior T C371
 Beckton Rose D741 LN
 Beckton Julian G1 J526
 Beckton Rose J725 EP
 Beckton Julian 7526G
 Beckton Marta 8955KR

DAM		Calv.Ease	BW	WW	YW	Milk	HPG	Stay	Maint.En.
Age	2	15	-3.7	24	57	15	9	13	-3.4
Wt	775	(.27)	(.60)	(.49)	(.41)	(.24)	(.01)	(.01)	(.10)
Wean Pct.	61%	Marb -0.07 (.26)		REA +0.36 (.25)		Bfat +0.00 (.20)			
Cow Eff.	129	BWt	WWt	WR	ADG	YWt	YR	Scr.	Fr.
		64	547	106	4	1117	111	38	4.5

★★★★★ for Low Maintenance, Gainability, Rib-eye area, High Cow Efficiency, Calving Ease, Stayability.

E-2 **BECKTON EPIC K4 N795**
1-A 100% # 916917 Tattoo: WF3 N795

Birth: 4-21-03
 Beckton Epic K F075
BECKTON EPIC KJ J722
 Ref. E-1
 Beckton Lana F891 JL
 Beckton Epic D404
BECKTON SIERRA J789 EP
 Beckton Sierra C157 CL
 Beckton Epic D404
 Beckton Belga D483 KR
 Beckton Clifftop T C075
 Beckton Lana 9610 TP
 Beckton Saga KJ B702
 Beckton Kuruba B508 PC
 Beckton Clipper JL A095
 Beckton Sierra A086 CL

DAM		Calv.Ease	BW	WW	YW	Milk	HPG	Stay	Maint.En.
Age	4	8	-0.3	35	85	10	8	10	-0.4
Wt	1095	(.63)	(.80)	(.74)	(.71)	(.62)	(.30)	(.15)	(.44)
Wean Pct.	54%	Marb +0.25 (.47)		REA +0.19 (.43)		Bfat +0.01 (.26)			
Cow Eff.	113	BWt	WWt	WR	ADG	YWt	YR	Scr.	Fr.
		85	619	106	4	1191	112	36	6.5

★★★★★ for Low Maintenance, Growth, Gainability, Marbling, Rib-eye area, Calving Ease.

• Reference Sires •

E-3 BECKTON EPIC R350 K
1-A 100% # 1042088 Tattoo: BKT5 R350

Birth: 3-17-05
 Beckton Epic D404
BECKTON EPIC K F075
 Ref. E
 Beckton Belga D483 KR
 Beckton Saga KJ B702
 Beckton Kuruba B508 PC
 Beckton Kaiser FD 9253
 Beckton Belga A036 MB
 Beckton Clipper JL A095
 Beckton Scarlet A742 RB
BECKTON LARKABA E042 CD
 Beckton Cody C401
 Beckton Larkaba C317 CL
 Beckton Clipper J 9956
 Bkt Larkaba 7596 PN

		Calv.Ease	BW	WW	YW	Milk	HPG	Stay	Maint.En.
DAM		11	-3.7	25	54	17	11	11	+1.0
Age 10		(.23)	(.26)	(.25)	(.25)	(.25)	(.19)	(.17)	(.18)
Wt NA		Marb +.14 (.01)		REA +.09 (.01)		Bfat +.01 (.01)			
Wean Pct. NA		BWt	WWt	WR	ADG	YWt	YR	Scr.	Fr.
Cow Eff. NA		95	696	108	4	1280	112	38	6.5

★★★★★ for Low Maintenance, Gainability, Marbling, Calving Ease.

H-1 BECKTON HERITAGE N013
1-A 100% # 916136 Tattoo: WF3 N013

Birth: 2-10-03
 Beckton Hustler CN J102
BECKTON HUSTLER C2 L079
 Ref. H-1
 Beckton Barmaid J012 CO
 Beckton Hustler C G407
 Beckton Belga G355 NP
 Beckton Copper JT G095
 Beckton Barmaid G565 LN
 Beckton Julian GG B571
 Beckton Annie F743 LN
BECKTON LANA L007 JL
 Beckton Julian G1 J526
 Beckton Lana J790 EP
 Beckton Epic K F075
 Beckton Lana F880 PL

		Calv.Ease	BW	WW	YW	Milk	HPG	Stay	Maint.En.
DAM		15	-6.4	27	54	17	10	12	+0.9
Age 2		(.57)	(.80)	(.73)	(.69)	(.53)	(.29)	(.01)	(.33)
Wt 975		Marb +.22 (.51)		REA +.04 (.47)		Bfat +.00 (.29)			
Wean Pct. 58%		BWt	WWt	WR	ADG	YWt	YR	Scr.	Fr.
Cow Eff. 122		57	648	115	4	1156	114	39	5.5

★★★★★ for Low Maintenance, Marbling, High Cow Efficiency, Calving Ease.

E-4 BECKTON EMCEE S466
1-A 100% # 1118929 Tattoo: BKT6 S466

Birth: 3-20-06
 Beckton Epic KJ J722
BECKTON EPIC K4 N795
 Ref. E-4
 Beckton Sierra J789 EP
 Beckton Warrior T C371
BECKTON LARKABA H798 WR
 Beckton Larkaba E042 CD
 Beckton Epic K F075
 Beckton Lana F891 JL
 Beckton Epic D404
 Beckton Sierra C157 CL
 JKG Chiefton L303
 Beckton Tamla A671 TR
 Beckton Cody C401
 Beckton Larkaba C317 CL

		Calv.Ease	BW	WW	YW	Milk	HPG	Stay	Maint.En.
DAM		13	-3.4	28	64	15	8	9	+0.9
Age 8		(.31)	(.59)	(.49)	(.43)	(.28)	(.14)	(.01)	(.15)
Wt 1175		Marb +.15 (.29)		REA +.16 (.28)		Bfat -.01 (.22)			
Wean Pct. 53%		BWt	WWt	WR	ADG	YWt	YR	Scr.	Fr.
Cow Eff. 111		73	621	105	4	1213	104	37	6.5

★★★★★ for Low Maintenance, Marbling, Rib-eye area, Calving Ease.



Beckton HalfmannHustler R588

E-5 BECKTON EPIC K6 S569
1-A 100% # 1119032 Tattoo: WF6 S569

Birth: 3-24-06
 Beckton Epic K F075
BECKTON EPIC KM M115
 Ref. E-2
 Beckton Minerva F495 CH
 Beckton Laramie L044
BECKTON SIERRA N703 LM
 Beckton Sierra L887 LN
 Beckton Epic D404
 Beckton Belga D483 KR
 Beckton Champ R A583
 Beckton Minerva CB69 JL
 Beckton Lancer T4 J536
 Beckton Sierra J659 DM
 Beckton Lancer TZ D525
 Beckton Sierra H442 HD

		Calv.Ease	BW	WW	YW	Milk	HPG	Stay	Maint.En.
DAM		10	-1.3	42	81	20	5	11	+1.5
Age 3		(.31)	(.61)	(.50)	(.43)	(.27)	(.01)	(.01)	(.15)
Wt 980		Marb +.04 (.29)		REA +.11 (.28)		Bfat +.01 (.21)			
Wean Pct. 65%		BWt	WWt	WR	ADG	YWt	YR	Scr.	Fr.
Cow Eff. 136		78	698	117	5	1342	119	37	6.0

★★★★★ for Low Maintenance, Growth, Gainability, High Cow Efficiency, Calving Ease.

H-2 BECKTON HALFMANNHUSTLER R588
1-A 100% # 1042326 Tattoo: BKT5 R588

Birth: 4-1-05
 Beckton Hustler C G407
BECKTON HUSTLER CN J102
 Ref. H
 Beckton Belga G355 NP
 Beckton Clipper JM A124
BECKTON VERNICE F513 CL
 Beckton Vernice A663 PC
 LCC Heaven or Bust 1000B
 Beckton Rose E032 CL
 Beckton Neptune RR B284
 Beckton Belga B061 ZN
 Beckton Clipper J 9956
 Beckton Mona 9766 MJ
 Beckton Pacer 8940
 Bkt Vernice 8994 NM

		Calv.Ease	BW	WW	YW	Milk	HPG	Stay	Maint.En.
DAM		12	-4.5	32	67	11	7	11	+5.0
Age 10		(.21)	(.36)	(.28)	(.29)	(.23)	(.16)	(.01)	(.16)
Wt 1305		Marb -.11 (.30)		REA -.04 (.28)		Bfat -.02 (.22)			
Wean Pct. 48%		BWt	WWt	WR	ADG	YWt	YR	Scr.	Fr.
Cow Eff. 100		67	620	103	5	1222	111	36	6.0

★★★★★ for Growth, Gainability, Calving Ease.

• Reference Sires •

H-3 BECKTON HASTEN H S462
1-A 100% # 1118925 Tattoo: BKT6 S462

Birth: 3-19-06
 Beckton Hustler C2 L079
BECKTON HASTEN P292
 Ref. H Beckton Sheba L644 CH
 Beckton Hustler CN J102
 Beckton Barmaid J012 C0
 Beckton Champ R3 H338
 Beckton Sheba CB73 JL
 Beckton Hadrian F C486
 Bkt Pine Marie C046 CH
BECKTON LAKME G128 HD
 Beckton Hadrian FC E166
 Beckton Lakme E373 CL
 Beckton Clipper KT C624
 Beckton Lakme C030 HB

DAM		Calv.Ease	BW	WW	YW	Milk	HPG	Stay	Maint.En.
Age	9	12	-3.3	33	65	18	10	10	+3.9
Wt	1100	(.29)	(.56)	(.45)	(.40)	(.27)	(.14)	(.10)	(.12)
Wean Pct.	62%	Marb +.03 (.26)		REA +.31 (.25)		Bfat -.01 (.20)			
Cow Eff.	129	BWt	WWt	WR	ADG	YWt	YR	Scr.	Fr.
		76	676	115	4	1200	108	36	5.5

★★★★★ for Low Maintenance, Growth, Gainability, Rib-eye area, High Cow Efficiency, Calving Ease.

J-3 BECKTON JUSTICE CH M056
1-A 100% # 854781 Tattoo: BKT2 M056

Birth: 2-22-02
 Beckton Justice G302
BECKTON JUSTICE C K449
 Ref. J Bkt Larkabel C742 CF
 Beckton Julian GG B571
 Bkt Vernice 9733 PC
 JKG Chiefton L303
 Bkt Larkabel 8541 ZP
 Beckton Hadrian A100
 Beckton Kuruba A444 FF
BECKTON RUTH K802 HD
 Beckton Hadrian F C486
 Beckton Ruth G534 NP
 Beckton Neptune RR B284
 Beckton Ruth B634 MB

DAM		Calv.Ease	BW	WW	YW	Milk	HPG	Stay	Maint.En.
Age	2	12	-1.5	34	68	9	12	11	-3.3
Wt	895	(.68)	(.81)	(.76)	(.74)	(.68)	(.34)	(.13)	(.52)
Wean Pct.	60%	Marb +.24 (.51)		REA +.14 (.46)		Bfat -.02 (.30)			
Cow Eff.	127	BWt	WWt	WR	ADG	YWt	YR	Scr.	Fr.
		71	622	114	4	1132	111	36	5.0

★★★★★ for Low Maintenance, Growth, Marbling, Rib-eye area, High Cow Efficiency, Calving Ease.

J-1 BECKTON JULIAN GG B571
1-A 100% # 387580 Tattoo: WF2 B571

Birth: 3-27-92
 Beckton Julian 6592
BECKTON JULIAN 7526G
 Ref. J Bkt Belga 6746 GS
 Beckton Trojan 5253
 Lchmn Christy 2339
 Beckton Gisa 4454
 Beckton Lalaxigu -2
 Beckton Julian 7526G
 Bkt Belga 6746 GS
BKT MARTA 9A13 JL
 Bkt Marta 6498 XM
 Beckton Xime 4736
 Beckton Marwa -K

DAM		Calv.Ease	BW	WW	YW	Milk	HPG	Stay	Maint.En.
Age	3	19	-5.9	29	56	15	5	24	-7.0
Wt	1015	(.90)	(.92)	(.91)	(.91)	(.90)	(.76)	(.70)	(.62)
Wean Pct.	56%	Marb +.10 (.72)		REA +.48 (.69)		Bfat +.02 (.58)			
Cow Eff.	118	BWt	WWt	WR	ADG	YWt	YR	Scr.	Fr.
		65	627	113	3	1140	112	NA	5.0

★★★★★ for Low Maintenance, Rib-eye area, High Cow Efficiency, Calving Ease, Stayability.

J-4 BECKTON JET L P491
1-A 100% # 978816 Tattoo: BKT4 P491

Birth: 3-22-04
 Beckton Julian GG B571
TR JULIAN LT151
 Ref. J-13 MS Geometric 917
 Beckton Julian 7526G
 Bkt Marta 9A13 JL
 BJR Yo 121
 MS Geometric
 Beckton Lancer TS D390
BECKTON MINERVA L278 LN
 Beckton Minerva F495 CH
 Beckton Lancer T A664
 Beckton Coca 7536 SB
 Beckton Champ R A583
 Beckton Minerva CB69 JL

DAM		Calv.Ease	BW	WW	YW	Milk	HPG	Stay	Maint.En.
Age	3	19	-7.7	13	37	18	8	16	+1.6
Wt	1055	(.57)	(.72)	(.66)	(.63)	(.56)	(.01)	(.23)	(.43)
Wean Pct.	52%	Marb +.23 (.38)		REA +.12 (.35)		Bfat +.00 (.24)			
Cow Eff.	109	BWt	WWt	WR	ADG	YWt	YR	Scr.	Fr.
		60	601	103	3	1067	104	38	4.0

★★★★★ for Low Maintenance, Marbling, Calving Ease, Stayability.

J-2 BECKTON JULIO L233
1-A 100% # 793330 Tattoo: WF1 L233

Birth: 3-10-01
 Beckton Julian GG B571
BECKTON JULIAN G1 J526
 Ref. J Beckton Annie F743 LN
 Beckton Epic K F075
BECKTON ROSE J725 EP
 Beckton Rose F192 CL
 Beckton Julian 7526G
 Bkt Marta 9A13 JL
 Beckton Lancer T A664
 Beckton Annie C132 NP
 Beckton Epic D404
 Beckton Belga D483 KR
 Beckton Clipper KC D400
 Beckton Rose D389 RD

DAM		Calv.Ease	BW	WW	YW	Milk	HPG	Stay	Maint.En.
Age	2	17	-5.6	20	46	9	10	14	-11.3
Wt	855	(.69)	(.80)	(.76)	(.74)	(.69)	(.35)	(.21)	(.54)
Wean Pct.	57%	Marb +.13 (.47)		REA +.06 (.43)		Bfat +.01 (.25)			
Cow Eff.	120	BWt	WWt	WR	ADG	YWt	YR	Scr.	Fr.
		64	562	114	4	1045	112	33	4.5

★★★★★ for Low Maintenance, Marbling, High Cow Efficiency, Calving Ease, Stayability.

J-5 BECKTON JULIAN GJ P535
1-A 100% # 978860 Tattoo: WF4 P535

Birth: 3-23-04
 Beckton Julian 6592
BECKTON JULIAN 7526G
 Ref. J Bkt Belga 6746 GS
 Beckton Julian GG B571
 Beckton Trojan 5253
 Lchmn Christy 2339
 Beckton Gisa 4454
 Beckton Lalaxigu -2
 Beckton Julian 7526G
 Beckton Coca 6004 NV
BECKTON MONA D086 JL
 Beckton Mona 9356 KR
 Beckton Kaiser 7143F
 Bkt Salute Mona 5810

DAM		Calv.Ease	BW	WW	YW	Milk	HPG	Stay	Maint.En.
Age	10	16	-5.2	26	57	1	15	16	-2.1
Wt	1115	(.46)	(.71)	(.62)	(.56)	(.44)	(.22)	(.28)	(.27)
Wean Pct.	54%	Marb +.14 (.41)		REA +.16 (.38)		Bfat +.01 (.28)			
Cow Eff.	114	BWt	WWt	WR	ADG	YWt	YR	Scr.	Fr.
		65	602	100	4	1139	108	37	5.0

★★★★★ for Low Maintenance, Marbling, Rib-eye area, Calving Ease, Stayability.

• Reference Sires •

J-6 **BECKTON JULIAN G3 P608**
1-A 100% # 978932 Tattoo: WF4 P608

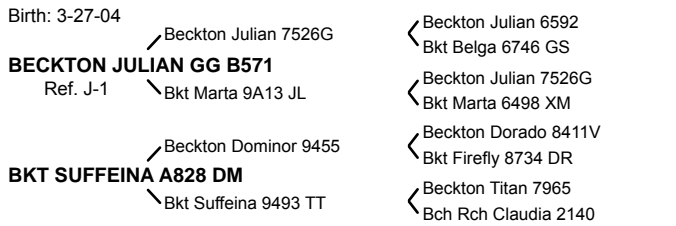

DAM		Calv.Ease	BW	WW	YW	Milk	HPG	Stay	Maint.En.
Age	13	19	-6.3	13	39	12	13	17	-5.2
Wt	NA	(.53)	(.77)	(.70)	(.65)	(.51)	(.23)	(.29)	(.40)
Wean Pct.	NA%	Marb +.20 (.47)		REA +.21 (.45)		Bfat +.01 (.35)			
Cow Eff.	NA	BWt	WWt	WR	ADG	YWt	YR	Scr.	Fr.
		72	627	106	4	1159	111	35	5.0

★★★★★ for Low Maintenance, Marbling, Rib-eye area, Calving Ease, Stayability.

J-9 **BECKTON ROMAN J S158**
1-A 100% # 1118621 Tattoo: BKT6 S158

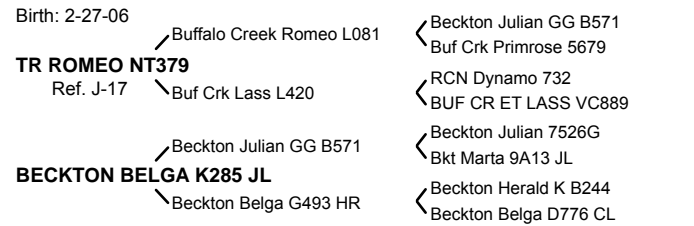

DAM		Calv.Ease	BW	WW	YW	Milk	HPG	Stay	Maint.En.
Age	6	11	+0.5	43	73	19	10	16	.0
Wt	1150	(.31)	(.59)	(.48)	(.42)	(.27)	(.15)	(.01)	(.16)
Wean Pct.	57%	Marb +.05 (.30)		REA +.49 (.29)		Bfat +.01 (.24)			
Cow Eff.	121	BWt	WWt	WR	ADG	YWt	YR	Scr.	Fr.
		79	660	113	4	1209	104	37	6.0

★★★★★ for Low Maintenance, Rib-eye area, High Cow Efficiency, Calving Ease, Stayability.

J-7 **BECKTON JUSTICE C1 R483**
1-A 100% # 1042221 Tattoo: BKT5 R483

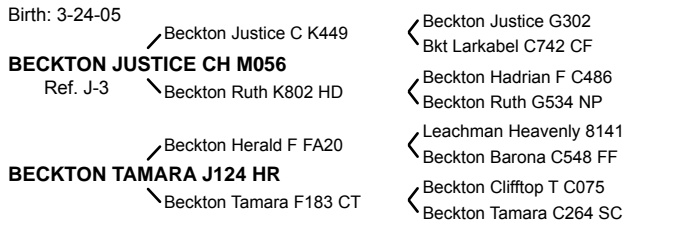

DAM		Calv.Ease	BW	WW	YW	Milk	HPG	Stay	Maint.En.
Age	6	14	-3.4	32	72	14	11	11	-1.3
Wt	1175	(.30)	(.67)	(.54)	(.48)	(.27)	(.15)	(.01)	(.17)
Wean Pct.	60%	Marb +.13 (.36)		REA +.10 (.34)		Bfat -.01 (.23)			
Cow Eff.	125	BWt	WWt	WR	ADG	YWt	YR	Scr.	Fr.
		76	700	109	4	1312	115	41	6.0

★★★★★ for Low Maintenance, Growth, Gainability, Marbling, High Cow Efficiency, Calving Ease.

J-10 **TR JULIAN LT142**
1-A 100% # 785183 Tattoo: TR2A1 LT1

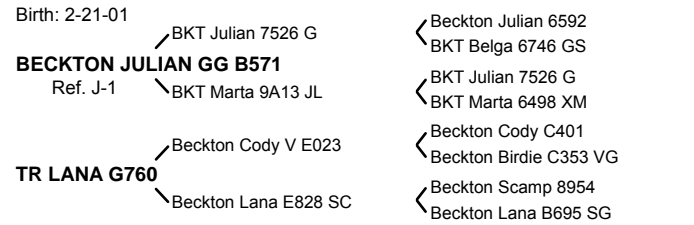

DAM		Calv.Ease	BW	WW	YW	Milk	HPG	Stay	Maint.En.
Age	4	21	-5.7	31	57	16	18	16	-4.5
Wt	NA	(.78)	(.86)	(.83)	(.82)	(.77)	(.62)	(.30)	(.56)
Wean Pct.	NA%	Marb +.08 (.57)		REA +.09 (.55)		Bfat -.01 (.40)			
Cow Eff.	NA	BWt	WWt	WR	ADG	YWt	YR	Scr.	Fr.
		76	782	113	3	1215	112	36	5.0

★★★★★ for Low Maintenance, Calving Ease, Stayability.

J-8 **BECKTON JULIAN G5 S107**
1-A 100% # 1118570 Tattoo: WF6 S107

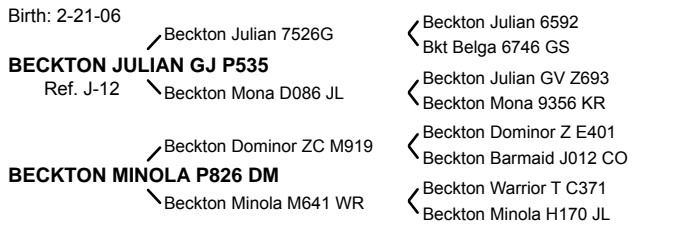

DAM		Calv.Ease	BW	WW	YW	Milk	HPG	Stay	Maint.En.
Age	2	10	-0.2	33	70	10	12	16	+1.9
Wt	1010	(.28)	(.58)	(.46)	(.40)	(.24)	(.01)	(.01)	(.01)
Wean Pct.	55%	Marb +.19 (.26)		REA +.08 (.25)		Bfat +.00 (.22)			
Cow Eff.	116	BWt	WWt	WR	ADG	YWt	YR	Scr.	Fr.
		74	640	115	4	1237	113	43	4.5

★★★★★ for Low Maintenance, Growth, Gainability, Marbling, High Cow Efficiency, Calving Ease, Stayability.

J-11 **TR JULIAN LT151**
1-A 100% # 785157 Tattoo: TR2A1 LT1

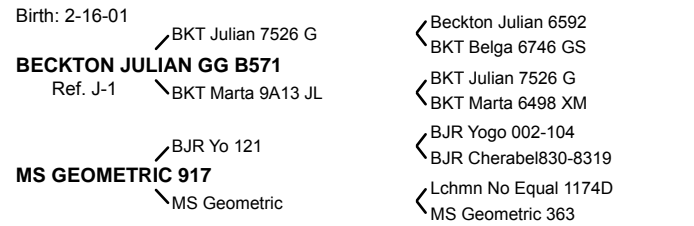

DAM		Calv.Ease	BW	WW	YW	Milk	HPG	Stay	Maint.En.
Age	2	16	-3.8	33	63	13	13	15	+5.5
Wt	NA	(.69)	(.79)	(.75)	(.74)	(.68)	(.42)	(.38)	(.48)
Wean Pct.	NA%	Marb +.26 (.52)		REA +.28 (.48)		Bfat +.00 (.32)			
Cow Eff.	NA	BWt	WWt	WR	ADG	YWt	YR	Scr.	Fr.
		79	739	114	3	1148	106	36	5.5

★★★★★ for Growth, Marbling, Rib-eye area, Calving Ease, Stayability.

• Reference Sires •



Tongue River Julian ST630

J-14 1-A 100% # 1121975 Tattoo: TR2A6 ST6

Birth: 2-21-06
 BKT Julian 7526 G
 Beckton Julian 6592
 BKT Belga 6746 GS
BECKTON JULIAN GG B571
 Ref. J-1 BKT Marta 9A13 JL
 BKT Julian 7526 G
 BKT Marta 6498 XM
 BJR Make My Day 981
 BJR Easy Rider 781
MS GEOMETRIC 003
 MS Geometric 277
 BJR Tow Kana 117-710
 BKT Julian 7526 G
 MS Geometric 962

DAM		Calv.Ease	BW	WW	YW	Milk	HPG	Stay	Maint.En.
Age	6	16	-3.9	27	55	11	13	18	+2.9
Wt	NA	(.33)	(.58)	(.49)	(.42)	(.31)	(.13)	(.20)	(.16)
Wean Pct.	NA	Marb +.22 (.01)		REA +.17 (.01)		Bfat +.01 (.01)			
Cow Eff.	NA	BWt	WWt	WR	ADG	YWt	YR	Scr.	Fr.
		76	690	NA	4	1303	NA	NA	6.5

★★★★★ for Low Maintenance, Marbling, Rib-eye area, Calving Ease, Stayability.

J-12 1-A 100% # 1045692 Tattoo: TR2A5 RT5

Birth: 3-25-05
 Beckton Julian 6592
 Beckton Trojan 5253
 Lchmn Christy 2339
BKT JULIAN 7526 G
 Ref. BKT Belga 6746 GS
 Beckton Gisa 4454
 BKT Lalaxigu-2
 Beckton Warrior T C371
 JKG Chiefton L303
BECKTON VERNICE G373 WR
 Beckton Vernice D066 NM
 Beckton Tamla A671 TR
 Beckton Nomad X 9972
 Beckton Vernice A140 JU

DAM		Calv.Ease	BW	WW	YW	Milk	HPG	Stay	Maint.En.
Age	8	13	-3.1	22	44	9	13	16	-4.4
Wt	NA	(.30)	(.58)	(.45)	(.40)	(.27)	(.21)	(.25)	(.18)
Wean Pct.	NA	Marb +.06 (.33)		REA +.14 (.32)		Bfat +.00 (.29)			
Cow Eff.	NA	BWt	WWt	WR	ADG	YWt	YR	Scr.	Fr.
		85	608	94	3	1103	95	38	5.0

★★★★★ for Low Maintenance, Rib-eye area, Calving Ease, Stayability.



Beckton Lancer F442 T

J-13 1-A 100% # 1045656 Tattoo: TR2A5 RT5

Birth: 2-20-05
 Beckton Julian GG B571
 Beckton Julian 7526G
 Bkt Marta 9A13 JL
TR JULIAN LT151
 Ref. J-13 MS Geometric 917
 BJR Yo 121
 MS Geometric
 RCN Dynamo 732
 Buf Crk Dynamics 3820
 Buf Crk Primrose 3150
TR DYNA HT824
 Buf Crk Dyna 3082
 Buf Crk Hobo 1961
 Buf Crk Dyna 1777

DAM		Calv.Ease	BW	WW	YW	Milk	HPG	Stay	Maint.En.
Age	7	13	-3.8	29	60	12	7	17	+2.0
Wt	1390	(.19)	(.36)	(.27)	(.27)	(.21)	(.16)	(.01)	(.11)
Wean Pct.	48%	Marb +.10 (.30)		REA +.22 (.29)		Bfat -.01 (.24)			
Cow Eff.	101	BWt	WWt	WR	ADG	YWt	YR	Scr.	Fr.
		78	664	103	4	1265	109	35	6.5

★★★★★ for Low Maintenance, Gainability, Rib-eye area, Calving Ease, Stayability.

L-1 1-A 100% # 533603 Tattoo: WF6 F442

Birth: 3-19-96
 Beckton Lancer 9380
 Beckton Trojan 5253
 Bkt Kilo Lana 4251
BECKTON LANCER T A664
 Ref. L Beckton Coca 9119 TJ
 Beckton Trojan 7061P
 Beckton Coca 7536 SB
 Beckton Dominor 9455
 Beckton Dorado 8411V
BKT SUFFEINA A828 DM
 Bkt Suffeina 9493 TT
 Bkt Firefly 8734 DR
 Beckton Titan 7965
 Bch Rch Claudia 2140

DAM		Calv.Ease	BW	WW	YW	Milk	HPG	Stay	Maint.En.
Age	5	11	-0.4	32	51	7	3	10	.0
Wt	1210	(.90)	(.94)	(.93)	(.92)	(.89)	(.73)	(.27)	(.61)
Wean Pct.	52%	Marb +.27 (.80)		REA +.49 (.76)		Bfat -.03 (.69)			
Cow Eff.	108	BWt	WWt	WR	ADG	YWt	YR	Scr.	Fr.
		82	623	112	3	1084	109	37	5.5

★★★★★ for Low Maintenance, Marbling, Rib-eye area, Calving Ease.

• Reference Sires •

L-2 BECKTON LANCER T9 N586
1-A 100% # 916708 Tattoo: BKT3 N586

Birth: 3-28-03
 Beckton Lancer T A664
BECKTON LANCER TA K644
 Ref. L Beckton Tamara B570 JL
 Beckton Lancer 9380
 Beckton Coca 9119 TJ
 Beckton Julian GN 9A45
 Bkt Tamara 8195 DN
 Beckton Scamp T A825
 Beckton Sierra B278 RN
 Beckton Julian GG B571
 Bkt Larkeisa C835 ZN
BKT LARKEISA H232 SC
 Beckton Scamp TR FB22
 Bkt Larkeisa F828 JL

		Calv.Ease	BW	WW	YW	Milk	HPG	Stay	Maint.En.
DAM		13	-2.0	22	41	10	12	11	-8.0
Age 5		(.62)	(.77)	(.71)	(.69)	(.62)	(.34)	(.19)	(.47)
Wt 990		Marb +0.09 (.43)		REA +0.09 (.39)		Bfat -0.01 (.23)			
Wean Pct. 61%		BWt	WWt	WR	ADG	YWt	YR	Scr.	Fr.
Cow Eff. 129		77	608	105	4	1070	102	37	5.5

★★★★★ for Low Maintenance, High Cow Efficiency, Calving Ease.

L-5 TR LANCER ST628
1-A 100% # 1122005 Tattoo: TR2A6 ST6

Birth: 2-21-06
 Beckton Lancer 9380
BECKTON LANCER T A664
 Ref. L Beckton Coca 9119 TJ
 Beckton Trojan 5253
 BKT Kilo Lana 4251
 Beckton Trojan 7061P
 Beckton Coca 7536 SB
 Buf Crk Hobo 1961
 MS Geometric 474
 Leachman Heavenly 8141
 MS Geometric 277
MS GEOMETRIC 928
 Algebra I 769
 MS Geometric 661

		Calv.Ease	BW	WW	YW	Milk	HPG	Stay	Maint.En.
DAM		17	-4.7	31	64	12	7	9	+10.3
Age 7		(.32)	(.51)	(.41)	(.37)	(.29)	(.13)	(.20)	(.15)
Wt NA		Marb +0.15 (.01)		REA -0.01 (.01)		Bfat +0.00 (.01)			
Wean Pct. NA%		BWt	WWt	WR	ADG	YWt	YR	Scr.	Fr.
Cow Eff. NA		90	705	NA	4	1369	NA	NA	7.5

★★★★★ for Gainability, Marbling, Calving Ease.

L-3 BECKTON LOKI CL S284
1-A 100% # 1118747 Tattoo: BKT6 S284

Birth: 3-10-06
 Beckton Loki F251
BECKTON LOKI C M740
 Ref. L BKT Larkeisa J051 CK
 Beckton Lancer TZ D525
 Bkt Pine Marie D126 JL
 Beckton Colt G552
 Bkt Larkeisa G448 CT
 Beckton Latigo G714
BECKTON LAKME J460 LT
 Beckton Lakme G128 HD
 Beckton Lancer TZ D525
 Beckton Marta Z381 CL
 Beckton Hadrian FC E166
 Beckton Lakme E373 CL

		Calv.Ease	BW	WW	YW	Milk	HPG	Stay	Maint.En.
DAM		12	-2.6	32	63	16	9	13	+3.7
Age 7		(.31)	(.59)	(.48)	(.42)	(.28)	(.15)	(.12)	(.17)
Wt 1160		Marb +0.14 (.28)		REA +0.10 (.27)		Bfat +0.00 (.21)			
Wean Pct. 55%		BWt	WWt	WR	ADG	YWt	YR	Scr.	Fr.
Cow Eff. 116		82	640	109	4	1198	103	39	6.0

★★★★★ for Low Maintenance, Marbling, High Cow Efficiency, Calving Ease, Stayability.



Beckton Nebula M045

L-4 BECKTON LIKABLE S633
1-A 100% # 1119096 Tattoo: WF6 S633

Birth: 3-28-06
 Beckton Lancer T A664
BECKTON LANCER F442 T
 Ref. L Bkt Suffeina A828 DM
 Beckton Lancer 9380
 Beckton Coca 9119 TJ
 Beckton Dominor 9455
 Bkt Suffeina 9493 TT
 Beckton Julian GG B571
BECKTON KIT F468 JL
 Beckton Kit A517 NP
 Beckton Julian 7526G
 Bkt Marta 9A13 JL
 Bkt Neptune 8460 R
 BchRch Kit935 35L416

		Calv.Ease	BW	WW	YW	Milk	HPG	Stay	Maint.En.
DAM		11	-1.3	30	49	10	5	13	-3.5
Age 10		(.22)	(.25)	(.24)	(.24)	(.24)	(.12)	(.01)	(.17)
Wt NA		Marb +0.21 (.01)		REA +0.43 (.01)		Bfat +0.00 (.01)			
Wean Pct. NA%		BWt	WWt	WR	ADG	YWt	YR	Scr.	Fr.
Cow Eff. NA		78	634	109	3	1098	99	36	5.5

★★★★★ for Low Maintenance, Marbling, Rib-eye area, Calving Ease, Stayability.

N-1 BECKTON NEBULA M045
1-A 100% # 854775 Tattoo: BKT2 M045

Birth: 2-19-02
 Beckton Neptune RR B284
BECKTON NEPTUNE R2 K065
 Ref. N Beckton Lana C735 TP
 Bkt Neptune 8460 R
 Beckton Eola 8600 RR
 RDD B Topper 1675
 Beckton Lana A714 TR
 Beckton Julian 7526G
 Bkt Marta 9A13 JL
 Beckton Herald K B244
 Beckton Belga D776 CL
BECKTON BELGA K285 JL
 Beckton Julian GG B571
 Beckton Belga G493 HR

		Calv.Ease	BW	WW	YW	Milk	HPG	Stay	Maint.En.
DAM		18	-6.3	29	62	6	10	14	-6.8
Age 2		(.72)	(.84)	(.80)	(.78)	(.72)	(.39)	(.18)	(.54)
Wt 860		Marb +0.15 (.51)		REA +0.24 (.46)		Bfat +0.00 (.29)			
Wean Pct. 59%		BWt	WWt	WR	ADG	YWt	YR	Scr.	Fr.
Cow Eff. 125		59	586	108	4	1080	106	35	5.0

★★★★★ for Low Maintenance, Growth, Marbling, Rib-eye area, High Cow Efficiency, Calving Ease, Stayability.

• Reference Sires •

N-2 BECKTON NEBULA E P084
1-A 100% # 978410 Tattoo: BKT4 P084

Birth: 2-27-04
 Beckton Neptune R2 K065
BECKTON NEBULA M045
 Ref. N-2 Beckton Belga K285 JL
 Beckton Neptune RR B284
 Beckton Lana C735 TP
 Beckton Julian GG B571
 Beckton Belga G493 HR
 Beckton Epic K F075
BKT PINE MARIE M119 EP
 Beckton Epic D404
 Beckton Lana D483 KR
 Beckton Julian GG B571
 Bkt Pine Marie D126 JL
 Bkt Pine Marie B849 JL

DAM		Calv.Ease	BW	WW	YW	Milk	HPG	Stay	Maint.En.
Age	2	19	-8.3	16	42	11	11	18	-7.4
Wt	885	(.43)	(.73)	(.63)	(.58)	(.41)	(.01)	(.01)	(.29)
Wean Pct.	55%	Marb +0.24 (.42)		REA +0.08 (.38)		Bfat +0.01 (.23)			
Cow Eff.	116	BWt	WWt	WR	ADG	YWt	YR	Scr.	Fr.
		54	559	100	3	1023	100	33	4.0

★★★★★ for Low Maintenance, Marbling, Calving Ease, Stayability.

N-4 BECKTON NEBULA P P707
1-A 100% # 979031 Tattoo: BKT4 P707

Birth: 4-1-04
 Beckton Neptune R2 K065
BECKTON NEBULA M045
 Ref. N-2 Beckton Belga K285 JL
 Beckton Neptune RR B284
 Beckton Lana C735 TP
 Beckton Julian GG B571
 Beckton Belga G493 HR
 Beckton Epic K1 K863
BECKTON LANA M809 EP
 Beckton Epic KN H110
 Beckton Rose H019 SC
 Beckton Lana K253 DM
 Beckton Dominor ZJ H657
 Beckton Lana HA34 DM

DAM		Calv.Ease	BW	WW	YW	Milk	HPG	Stay	Maint.En.
Age	2	16	-4.9	37	71	15	8	13	-7.8
Wt	890	(.50)	(.68)	(.61)	(.58)	(.49)	(.15)	(.01)	(.37)
Wean Pct.	71%	Marb +0.18 (.34)		REA +0.13 (.31)		Bfat +0.01 (.21)			
Cow Eff.	150	BWt	WWt	WR	ADG	YWt	YR	Scr.	Fr.
		68	728	127	4	1265	122	37	5.0

★★★★★ for Low Maintenance, Growth, Marbling, Rib-eye area, High Cow Efficiency, Calving Ease, Stayability.



Beckton Nebula L P093

N-5 BECKTON NEBULA N R573
1-A 100% # 1042311 Tattoo: BKT5 R573

Birth: 3-29-05
 Beckton Neptune R2 K065
BECKTON NEBULA M045
 Ref. N-2 Beckton Belga K285 JL
 Beckton Neptune RR B284
 Beckton Lana C735 TP
 Beckton Julian GG B571
 Beckton Belga G493 HR
 Beckton Lancer F442 T
BECKTON LANA M621 LN
 Beckton Lancer T A664
 Bkt Suffeina A828 DM
 Beckton Lana H329 HD
 Beckton Hadrian FH E143
 Beckton Lana D288 VG

DAM		Calv.Ease	BW	WW	YW	Milk	HPG	Stay	Maint.En.
Age	3	14	-3.5	28	54	9	9	15	-4.7
Wt	940	(.29)	(.69)	(.56)	(.49)	(.26)	(.01)	(.01)	(.15)
Wean Pct.	59%	Marb +0.22 (.38)		REA +0.08 (.35)		Bfat -0.01 (.23)			
Cow Eff.	124	BWt	WWt	WR	ADG	YWt	YR	Scr.	Fr.
		66	610	100	4	1191	107	37	4.5

★★★★★ for Low Maintenance, Gainability, Marbling, High Cow Efficiency, Calving Ease, Stayability.

N-3 BECKTON NEBULA L P093
1-A 100% # 978419 Tattoo: WF4 P093

Birth: 2-28-04
 Beckton Neptune R2 K065
BECKTON NEBULA M045
 Ref. N-2 Beckton Belga K285 JL
 Beckton Neptune RR B284
 Beckton Lana C735 TP
 Beckton Julian GG B571
 Beckton Belga G493 HR
 Beckton Lancer TA K644
BECKTON MARTA M021 LN
 Beckton Lancer T A664
 Beckton Tamara B570 JL
 Beckton Lancer T A664
 Beckton Marta K254 LN
 Beckton Marta G512 LN

DAM		Calv.Ease	BW	WW	YW	Milk	HPG	Stay	Maint.En.
Age	2	14	-2.8	36	71	3	8	15	-3.7
Wt	775	(.40)	(.77)	(.67)	(.62)	(.37)	(.01)	(.01)	(.27)
Wean Pct.	63%	Marb +0.13 (.44)		REA +0.37 (.40)		Bfat -0.01 (.24)			
Cow Eff.	132	BWt	WWt	WR	ADG	YWt	YR	Scr.	Fr.
		69	560	101	4	1067	105	35	5.5

★★★★★ for Low Maintenance, Marbling, Rib-eye area, High Cow Efficiency, Calving Ease, Stayability.

N-6 BECKTON NEBULA G S237
1-A 100% # 1118700 Tattoo: WF6 S237

Birth: 3-6-06
 Beckton Neptune R2 K065
BECKTON NEBULA M045
 Ref. N-2 Beckton Belga K285 JL
 Beckton Neptune RR B284
 Beckton Lana C735 TP
 Beckton Julian GG B571
 Beckton Belga G493 HR
 Beckton Julian 7526G
BECKTON LAKME LA06 JL
 Bkt Marta 9A13 JL
 Beckton Lakme B370 HV
 Leachman Heavenly 8141
 Beckton Lakme 9211DT

DAM		Calv.Ease	BW	WW	YW	Milk	HPG	Stay	Maint.En.
Age	5	17	-3.5	28	54	7	10	16	-7.2
Wt	998	(.30)	(.60)	(.48)	(.42)	(.26)	(.01)	(.01)	(.16)
Wean Pct.	52%	Marb +0.11 (.30)		REA +0.20 (.29)		Bfat +0.01 (.24)			
Cow Eff.	110	BWt	WWt	WR	ADG	YWt	YR	Scr.	Fr.
		63	519	88	4	1036	96	39	5.0

★★★★★ for Low Maintenance, Gainability, Marbling, Rib-eye area, Calving Ease, Stayability.

• Reference Sires •

N-7 BECKTON NEBULA EN S347
1-A 100% # 1118810 Tattoo: WF6 S347

Birth: 3-13-06

Beckton Nebula M045
BECKTON NEBULA E P084
Ref. N-3 \ BKT Pine Marie M119 EP

Beckton Nebula M045
BECKTON EOLA P530 NB
\ Beckton Eola M663 EP

Beckton Neptune R2 K065
Beckton Belga K285 JL
Beckton Epic K F075
Bkt Pine Marie D126 JL
Beckton Neptune R2 K065
Beckton Belga K285 JL
Beckton Epic K1 K863
Beckton Eola K178 EP

Calv.Ease	BW	WW	YW	Milk	HPG	Stay	Maint.En.
18	-6.8	23	49	10	11	17	-8.1
(.27)	(.59)	(.48)	(.41)	(.24)	(.01)	(.01)	(.10)

DAM	
Age	2
Wt	750
Wean Pct.	60%
Cow Eff.	127

Marb	REA	Bfat
+38	+01	+01
(.27)	(.25)	(.20)

BWt	WWt	WR	ADG	YWt	YR	Scr.	Fr.
55	521	97	4	1009	97	NA	4.5

★★★★★ for Low Maintenance, Gainability, Marbling, High Cow Efficiency, Calving Ease, Stayability.



Beckton Warrior N645 T1

N-8 BECKTON NEBULA PJ S543
1-A 100% # 1119006 Tattoo: BKT6 S543

Birth: 3-23-06

Beckton Nebula M045
BECKTON NEBULA P P707
Ref. N-5 \ Beckton Lana M809 EP

Beckton Julio L233
BECKTON LANA P685 JO
\ Beckton Lana E083 CD

Beckton Neptune R2 K065
Beckton Belga K285 JL
Beckton Epic K1 K863
Beckton Lana K253 DM
Beckton Julian G1 J526
Beckton Rose J725 EP
Beckton Cody C401
Beckton Lana C220 CL

Calv.Ease	BW	WW	YW	Milk	HPG	Stay	Maint.En.
15	-4.2	38	73	14	9	14	-1.5
(.27)	(.59)	(.47)	(.40)	(.24)	(.01)	(.01)	(.12)

DAM	
Age	2
Wt	1000
Wean Pct.	58%
Cow Eff.	121

Marb	REA	Bfat
+15	+12	+01
(.25)	(.24)	(.20)

BWt	WWt	WR	ADG	YWt	YR	Scr.	Fr.
68	661	126	4	1216	120	35	6.5

★★★★★ for Low Maintenance, Growth, Gainability, Marbling, High Cow Efficiency, Calving Ease, Stayability.

W-1 BECKTON WARRIOR N645 T1
1-A 100% # 916767 Tattoo: BKT3 N645

Birth: 4-2-03

Beckton Warrior TC E801
BECKTON WARRIOR T1 H281
Ref. W \ Beckton Minerva B609 RN

Beckton Epic K F075
BECKTON ROSE H074 EP
\ Beckton Rose F791 EM

Beckton Warrior T C371
Beckton Minola C251 NM
Beckton Ranger H Z095
Beckton Minerva Z936 RN
Beckton Epic D404
Beckton Belga D483 KR
Beckton Emperor C369
Beckton Rose C794 KR

Calv.Ease	BW	WW	YW	Milk	HPG	Stay	Maint.En.
5	-0.2	40	78	8	9	10	-1.0
(.31)	(.66)	(.54)	(.45)	(.27)	(.15)	(.01)	(.16)

DAM	
Age	5
Wt	1020
Wean Pct.	67%
Cow Eff.	140

Marb	REA	Bfat
-01	+01	+01
(.36)	(.34)	(.23)

BWt	WWt	WR	ADG	YWt	YR	Scr.	Fr.
85	679	117	3	1204	115	37	6.5

★★★★★ for Low Maintenance, Growth, High Cow Efficiency.

V-1 BECKTON VEGA P079
1-A 100% # 978405 Tattoo: BKT4 P079

Birth: 2-26-04

Beckton Vegas SV H078
BECKTON VEGAS S1 K316
Ref. V \ Beckton Eola H073 EP

Beckton Julian GG B571
BECKTON LYDIA H159 JL
\ Beckton Lydia D386 CL

Beckton Vegas S F382
Beckton Larkaba F252 VG
Beckton Epic K F075
Beckton Eola F467 CD
Beckton Julian 7526G
Bkt Marta 9A13 JL
Beckton Clipper K Z420
Bkt Lydia 9B78 VK

Calv.Ease	BW	WW	YW	Milk	HPG	Stay	Maint.En.
13	-2.3	25	53	15	11	12	+6.1
(.43)	(.70)	(.60)	(.54)	(.41)	(.17)	(.11)	(.29)

DAM	
Age	6
Wt	1180
Wean Pct.	51%
Cow Eff.	108

Marb	REA	Bfat
-05	+39	+00
(.38)	(.35)	(.22)

BWt	WWt	WR	ADG	YWt	YR	Scr.	Fr.
73	603	98	4	1139	104	35	5.0

★★★★★ for Rib-eye area, Calving Ease.

W-2 BECKTON WARRIOR C1 S337
1-A 100% # 1118800 Tattoo: WF6 S337

Birth: 3-12-06

Beckton Warrior C C355
BECKTON WARRIOR CL M686
Ref. W \ Beckton Christy J223 LN

Beckton Cody V E023
BECKTON CHRISTY K101 CD
\ Beckton Christy C306 JL

JKG Chiefton L303
Bkt Christy 9A01 CL
Beckton Lancer TL G626
Beckton Christy G249 JL
Beckton Cody C401
Beckton Birdie C353 VG
Beckton Julian 7526G
Beckton Christy Z264 NP

Calv.Ease	BW	WW	YW	Milk	HPG	Stay	Maint.En.
16	-3.0	33	66	13	12	11	+1.7
(.30)	(.59)	(.48)	(.42)	(.27)	(.01)	(.10)	(.15)

DAM	
Age	6
Wt	1085
Wean Pct.	63%
Cow Eff.	132

Marb	REA	Bfat
+10	+19	+00
(.28)	(.27)	(.22)

BWt	WWt	WR	ADG	YWt	YR	Scr.	Fr.
81	682	116	5	1249	112	36	5.5

★★★★★ for Low Maintenance, Growth, Gainability, Rib-eye area, High Cow Efficiency, Calving Ease.

Predicting Profit...

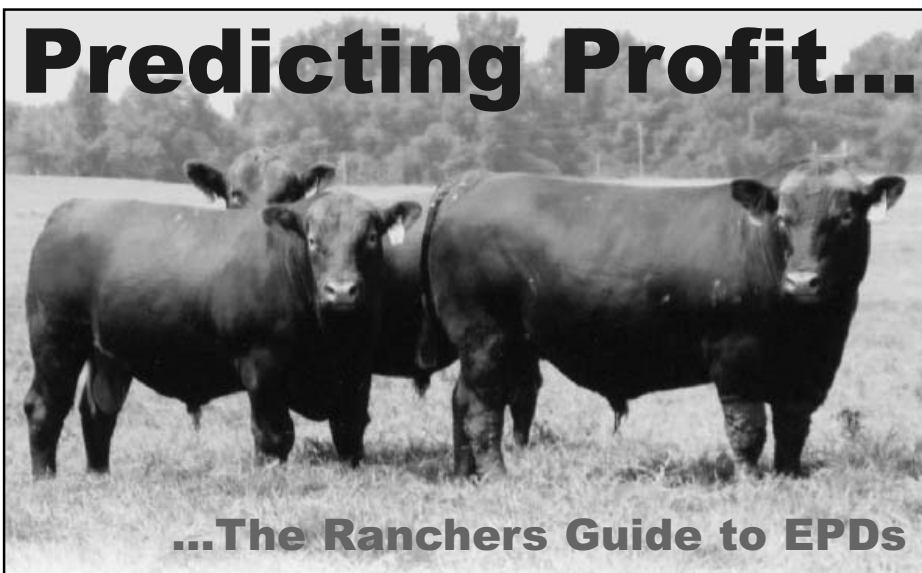

EPDs (Expected Progeny Differences) are the most powerful selection tool the beef industry has ever had.

The use of EPDs has converted selecting range bulls from an art form to a science, better preparing cow/calf producers to make genetic decisions which may ultimately improve their profitability.

Better Selection Tools Make Better Bulls

Red Angus remains the only major beef breed with mandatory Total Herd Reporting (THR), which requires the annual production of each cow and the performance of every calf raised through weaning to be reported. Red Angus EPDs are calculated from complete contemporary group data - not just the data from the calves good enough to register.



Completely Described Beef Production: Reproduction • Growth Carcass • Maintenance

Profit starts at Reproduction!

Research has shown that reproduction has four to ten times the economic impact of carcass traits. Yet, Red Angus is the only breed that completely describes cow herd reproduction from birth through profitable lifespan. Red Angus reproductive EPDs are expressed as percent probability, meaning the higher the EPD, the more likely the desired observation.

Profitable reproduction can be boiled down to success in these four Economically Relevant Traits:

Calving Ease Direct (CED): The expected progeny difference of calves being born unassisted from two year-old heifers. The Red Angus CED model accounts for contemporary group birth weight differences and calving ease scores.

Heifer Pregnancy (HPG): The expected progeny difference of heifers conceiving to calve at two years of age.

Calving Ease Maternal (CEM): The expected progeny difference of a given animal's daughters calving unassisted at two years of age.

Stayability (STAY): The expected progeny difference of a bull's daughters remaining in the herd until at least six years of age. Females that don't stay in the herd that long are losing money, and they also contribute to a higher rate of replacement females that the rancher can't cash crop.

Cows Eat Money! That's why Red Angus published the Mature Cow Maintenance Energy EPD (ME EPD), becoming the first beef breed to evaluate the expense side of the ranchers' profit equation. Here are the facts:

- ME predicts differences in maintenance energy requirements of mature daughters of a bull.
- Maintenance energy requirements are directly related to feed cost - often producers' largest single expense.
- The lower the ME EPD, the less feed daughters require to maintain body condition.
- ME can be used to ensure environmental fit, and to estimate additional feed required by increased growth & milk.

Growth & Carcass Traits!

Red Angus publishes genetic predictions for birth weight, weaning weight, yearling weight, milk, total maternal, marbling score, rib eye area, and 12th rib fat thickness. Red Angus utilizes real time ultrasound data in conjunction with actual carcass data in the calculation of marbling and rib eye area EPDs. Genetic predictions for each of these revenue traits are more reliable because they are built with Total Herd Reporting.

Red Angus Bulls Described	Trait	Expressed in (units)	2/3 of yearling Red Angus bulls fit in this EPD range		
Yearling Red Angus Bulls	CED	% Probability	6	2	10
Yearling Red Angus Bulls	BW	Pounds	0.3	2.5	-1.9
Yearling Red Angus Bulls	WW	Pounds	32	24	40
Yearling Red Angus Bulls	YW	Pounds	56	43	69
Yearling Red Angus Bulls	Milk	Pounds	17	12	22
Yearling Red Angus Bulls	TM	Pounds	32	25	39
Active Red Angus Bulls	ME	Mcal/Month	4	9	-1
Active Red Angus Bulls	HPG	% Probability	9	6	12
Yearling Red Angus Bulls	CEM	% Probability	3	0	6
Yearling Red Angus Bulls	STAY	% Probability	9	6	12
Yearling Red Angus Bulls	MARB	Marbling Score	0.07	-0.04	0.18
Yearling Red Angus Bulls	REA	Square Inches	0.07	-0.10	0.24
Yearling Red Angus Bulls	BF	Inches	0.00	0.01	-0.01

To receive a **FREE 8-page "Rancher's Guide to EPDs"** or a **Red Angus Sire Summary**, contact this breeder or the **Red Angus Association of America**.



Building Better Beef...

Red Angus

(940) 387-3502 • RedAngus.org

Abbreviations and Explanation of Terms

Tattoo – The animal's ear tattoos.

Cat – An animal's category under the Red Angus recordation system.

- ▶ **1-A** – Purebred 100% Red Angus with no disqualifying characteristics.
- ▶ **1-B** – 87% to 99% Red Angus with no disqualifying characteristics.
- ▶ **2** – 1-A and 1-B animals that are disqualified from those categories for white in front of the navel, or other disqualifying characteristics.

EPD – Expected Progeny Difference. The expected difference in performance of an animal's progeny when those progeny are compared to progeny of an animal with an EPD of zero for the trait in question. EPD values are relative. They are the only statistically valid way to compare the expected progeny performance of different animals.

Acc – Accuracy measures the reliability of the EPD. It reflects the amount and distribution of information contributing to an EPD, and can range from a low of .0 to a high of 1.0. Non-parent EPDs have extremely low numerical accuracy.

Possible Change – An estimate of the amount of change (in trait units) that can be expected for an animal's EPDs based on its level of accuracy. An animal's true EPD will lie within one possible change unit of the stated value two-thirds of the time.

List of EPDs

BW – The birth weight EPD is measured in pounds of weight difference at birth.

WW – The weaning weight EPD is measured in pounds of weight difference at a 205 day weaning age.

YW – The yearling weight EPD is measured in pounds of weight difference at 365 days of age.

Milk – The milk EPD is the weight difference at 205 days which can be attributed to the milk production and female characteristics of the daughters of the animal.

Mat – The total maternal EPD is the total weight difference at 205 days which can be attributed to the dam of an animal alone.

CEd – The calving ease direct EPD is the probability that an animal's calves will calve unassisted to a two-year old dam.

CEm – The maternal calving ease EPD is the probability that an animal's daughters will calve unassisted as two-year olds.

ST – The stayability EPD is the probability that, after an animal's daughters enter the cowherd, they will remain productive until at least six years old.

Dam's Age – The dam's age at the time of calving.

Dam's Wt – The dam's weight if taken at weaning time.

Progeny Average – The average actual birth weight, weaning ratio and yearling ratio for all of the dam's progeny, excluding ETs and twins.

BW – The animal's actual birth weight.

AWW – Adjusted Weaning Weight. Weaning weight adjusted to 205 days and corrected for age of dam.

ADG – Average Daily Gain of the bull while on the test period from October to February.

AYW – Adjusted Yearling Weight. Animal's yearling weight adjusted to 365 days.

Fr – A measure of hip height adjusted for age and age of dam and converted to an alternative scale to provide meaningful comparisons within the animals in the sale.

Scr – A bull's Scrotal Measurement in centimeters adjusted to 365 days of age.

WR – Weaning Ratio. The ratio of an animal's AWW to the others in its weaning contemporary group within the same herd (x 100).

YR – Yearling Ratio. The ratio of an animal's AYW to the others in its yearling contemporary group within the same herd (x 100).

PRI Cow Efficiency – A measure of how efficient the dam/calf pair is compared to the long-standing PRI base-point of 100.

HPG – The heifer pregnancy EPD measures the percent probability that an animal's daughters will calve, as a two year old.

ME – The maintenance energy requirement EPD measure & degree is the difference in megacalories per month that the progeny of the animal will require to sustain itself alone.

Marb – The marbling EPD is the difference in marbling score in the progeny of the animal. Marbling score ranges from 2 to 10 and is the basis for USDA quality grading. A difference of 1.00 is roughly equivalent to one-third of a quality grade (Ch vs. Chi-). It is the most important part of the quality grade determination for a beef carcass.

REA – The rib-eye EPD is the difference in square inches in the size of the longissimus muscle (the ribeye muscle, as measured at the 12/13 rib) of an animal's progeny. It is a component in the calculation of carcass cutability or yield grade or percent retail beef.

Bfat – The backfat EPD is the difference in inches in exterior fat thickness in the progeny of the animal. In carcasses, it is measured at the 12/13 rib for ultrasound measurements. It is the most important component in the determination of cutability or yield grade or percent retail beef. It also represents fat which may need to be trimmed off.

Sale Terms and Conditions

Except for those stated in the terms and conditions below, there are no warranties, either expressed or implied, as to the merchantability or fitness for a particular purpose with respect to the cattle being sold at this auction. The warranties and guarantees set forth in the "Terms and Conditions" are in lieu of all other warranties, either expressed or implied, and the remedies provided therein shall be the sole and exclusive remedy for the Buyer, or any party claiming through Buyer, for any breach of warranty or guarantee therein provided, and all other obligations or liabilities.

The information in the catalog is believed to be accurate, and the information seller believes to be most representative. It is the nature of seller's business that the seller engages in a continual process of collecting new data and information. Therefore, any information presented at the time of sale is always subject to revision, correction or update.

I. BIDDING

The Auctioneer in charge will settle any disputes as to bids, and his decision on such matters shall be final.

II. TERMS

Terms of sale are cash or personal check unless satisfactory credit arrangements have been made with vendor prior to sale.

III. PURCHASER'S RISK

Each animal becomes the risk of the purchaser as soon as sold, but it shall be the obligation of the Seller to see that animals are fed and cared for free of charge to purchaser, until loaded for shipment or until the expiration of 48 hours after the sale, whichever occurs sooner.

IV. DELIVERY

For any animals for which delivery or 'free delivery' is offered, the following terms shall apply. Each animal becomes the risk of the purchaser as soon as sold, and through the time of delivery. The seller will arrange transportation and delivery schedules, and may combine animals from one or more purchasers for convenience and to reduce costs. If 'free delivery' is offered, seller will pay the cost of transportation, but assumes no other liability. Once the purchaser has been notified of the date and approximate time of delivery (morning, afternoon, evening, etc.), it is the responsibility of the purchaser to arrange adequate and agreeable location and facilities for unloading each animal. When unloaded at the agreed upon location, all care and management of the animal is the responsibility of the purchaser.

V. CERTIFICATE OF REGISTRY

A transferred certificate of registry will be furnished to the purchaser for each animal.

VI. HEALTH

All animals are eligible for interstate shipment, except as otherwise announced. Interstate health papers will be furnished for each animal requiring T.B. and Bang's tests in accordance with Federal Regulations.

VII. A.I. NON-OWNER BULL PERMITS

A.I./Non-owner Bull Permits shall be furnished by the Seller, at no cost to the Buyer, for all females bred artificially or naturally to bulls not owned by the Seller.

VIII. ANNOUNCEMENTS

Any changes from information of any kind in this catalog will be announced from the auction box and such announcements shall take precedence.

IX. BREEDING GUARANTEE

All animals are sold as guaranteed breeders. Each bull has been officially fertility tested as "Satisfactory Breeder" prior to the sale. However, seller cannot guarantee against physical injury or illness following the sale. But if within 8 months following the sale, the buyer has evidence that the animal is not a breeder, the buyer may obtain a statement signed by a licensed veterinarian to that effect, such statement also indicating that there has been no injury or illness to the animal following the sale, and return the bull to the farm of the seller for adjustment. If the seller cannot then prove the animal to be a breeder, an adjustment will be made by the seller, either by substituting an animal of equal value, or by the refund of the full purchase price. Such adjustment shall be considered full settlement and satisfaction of all claims. No guarantees apply to animals which are shown following the sale.

Any female that has had a calf prior to the date of sale shall be considered a breeder without further guarantee. Any female that has not had a calf prior to the sale, and which fails to conceive after having been exposed to a bull of demonstrated fertility for at least 60 days, may be returned to the seller at the buyer's expense for a full refund of the purchase price. Such refund shall be considered full adjustment and no further adjustment or compensation shall be due. All pedigree and breeding information represents the best estimate at the time it is collected, but is subject to revision or correction in the future.

X. GENETIC DEFECT AND PARENTAGE GUARANTEE

For complete rules and regulations in regard to genetic defects or parentage guarantee contact the RAAA. Ask for section XI - in the Sales and Terms Recommended policy.

XI. RETAINED INTEREST AND SEMEN RIGHTS:

Buyer receives full possession and salvage value of all bulls in the sale, unless stated otherwise in the catalog or during the auction. On specific animals designated in the catalog or from the auction block, Seller is retaining an undivided 1/2 interest or other interest as stated. We reserve the right to collect and market semen on these bulls. Collection would be during the off season, at the buyer's convenience, and at seller's expense. The buyer has the option of obtaining semen at the same time, at cost, provided we are notified ahead of collection. If the buyer collects the bull, we would like to be notified so we may obtain semen if wanted.

On all other bulls in the Sale, except those so designated, the buyer has full possession, and shall have the sole privilege to determine if the bull is to have semen collected at any time in the future. On such bulls which are collected in the future, and from which semen is advertised or marketed commercially, seller retains a 1/3 royalty interest on any semen which is sold; however, any decision to collect or sell semen is solely the right of the buyer.

XII. RIGHTS AND OBLIGATIONS

A. The above terms and conditions of sale shall constitute a contract between the Buyer and Seller of each animal and shall be equally binding upon both. Each sale or resale of an animal constitutes a separate transaction.

B. Neither the sale manager, the owner, nor any other person connected with the management of the sale, assumes any liability, legal or otherwise.

The Red Angus Association is developing a DNA marker test for osteopetrosis, which is expected soon. Buffalo Creek Romeo L081 has been identified as a carrier. We have not used Romeo significantly, but he can appear back in the pedigree on a few animals. If you purchase an animal descended from Romeo, and once this genetic test is developed, you may have him tested at our expense. The probability of a descendent being a carrier is very small, if such an animal should be a carrier, we will take the animal back and give you a full refund of your purchase price.

RAAA Herd EPD Tables

Proven and Genetic Opportunity Sires (2009)

	CED	BW	WW	YW	MILK	TM	ME	HPG	CEM	ST	MARB	REA	FAT
Min	-15	-8.3	-7	-6	-8	0	-19	-7	-14	0	-.50	-.74	-.06
Avg	6	0.2	33	59	17	34	4	9	3	8	.06	.05	.00
Max	29	9.1	69	109	37	56	23	22	25	20	.66	.88	.06
Var	25	7.0	105	290	36	68	27	9	19	9	.02	.05	.00
1%	18	-5.9	57	99	31	53	-8	16	13	15	.38	.55	-.03
2%	16	-5.2	54	94	29	51	-7	15	12	14	.34	.49	-.03
3%	15	-4.8	52	91	28	49	-6	15	11	14	.32	.46	-.02
4%	15	-4.4	51	89	28	48	-5	14	11	13	.30	.43	-.02
5%	14	-4.1	50	87	27	48	-5	14	10	13	.28	.41	-.02
10%	12	-3.2	46	81	25	45	-3	13	9	12	.23	.33	-.02
15%	11	-2.5	44	77	23	43	-1	12	8	11	.20	.27	-.01
20%	10	-2.0	42	73	22	41	0	12	7	11	.17	.23	-.01
25%	9	-1.6	40	70	21	40	1	11	6	10	.15	.20	-.01
30%	9	-1.2	38	68	20	38	1	11	5	10	.13	.16	-.01
35%	8	-0.8	37	66	19	37	2	10	5	9	.11	.13	.00
40%	7	-0.5	36	63	19	36	3	10	4	9	.09	.10	.00
45%	7	-0.1	34	61	18	35	3	9	4	8	.08	.08	.00
50%	6	0.2	33	59	17	34	4	9	3	8	.06	.05	.00
55%	5	0.5	32	57	16	33	5	9	2	8	.04	.02	.00
60%	5	0.9	30	55	15	32	5	8	2	7	.03	.00	.00
65%	4	1.2	29	52	15	31	6	8	1	7	.01	-.03	.00
70%	3	1.6	28	50	14	30	7	7	1	6	-.01	-.06	.01
75%	3	2.0	26	48	13	28	7	7	0	6	-.03	-.10	.01
80%	2	2.4	24	45	12	27	8	6	-1	5	-.05	-.13	.01
85%	1	2.9	22	41	11	25	9	6	-2	5	-.08	-.17	.01
90%	0	3.6	20	37	9	23	11	5	-3	4	-.11	-.23	.02
95%	-2	4.5	16	31	7	20	13	4	-4	3	-.16	-.31	.02

Active Cows (2009)

	CED	BW	WW	YW	MILK	TM	ME	HPG	CEM	ST	MARB	REA	FAT
Min	-10	-9.1	-15	-23	-8	-5	-22	-5	-15	-1	-.41	-.77	-.05
Avg	5	0.5	30	52	16	31	4	9	3	8	.05	.00	.00
Max	24	11.2	66	109	38	63	44	20	17	24	.79	.74	.06
Var	15	4.8	66	194	29	60	20	5	12	6	.01	.03	.00
1%	14	-4.6	49	84	29	49	-6	14	11	14	.32	.39	-.02
2%	13	-4.0	47	81	27	47	-5	14	10	13	.29	.35	-.02
3%	12	-3.6	45	78	26	46	-4	13	10	13	.27	.32	-.02
4%	12	-3.3	44	76	26	45	-4	13	9	12	.25	.30	-.02
5%	11	-3.1	43	75	25	44	-3	13	9	12	.24	.28	-.02
10%	10	-2.3	40	70	23	41	-2	12	7	11	.20	.22	-.01
15%	9	-1.8	38	66	22	39	-1	11	7	11	.17	.17	-.01
20%	8	-1.3	37	64	21	38	0	11	6	10	.15	.14	-.01
25%	8	-1.0	35	61	20	36	1	11	5	10	.13	.11	-.01
30%	7	-0.6	34	59	19	35	2	10	5	9	.11	.09	-.01
35%	6	-0.3	33	57	18	34	2	10	4	9	.10	.06	.00
40%	6	-0.1	32	56	17	33	3	10	4	9	.08	.04	.00
45%	5	0.2	31	54	17	32	3	9	3	8	.06	.02	.00
50%	5	0.5	30	52	16	31	4	9	3	8	.05	.00	.00
55%	5	0.8	29	50	15	30	5	9	3	8	.04	-.02	.00
60%	4	1.1	28	48	15	29	5	8	2	7	.02	-.04	.00
65%	4	1.3	27	47	14	28	6	8	2	7	.00	-.06	.00
70%	3	1.6	26	45	13	27	6	8	1	7	-.01	-.09	.01
75%	2	2.0	25	43	12	26	7	7	1	6	-.03	-.11	.01
80%	2	2.3	23	40	11	24	8	7	0	6	-.05	-.14	.01
85%	1	2.8	22	38	10	23	9	7	-1	5	-.07	-.17	.01
90%	0	3.3	20	34	9	21	10	6	-1	5	-.10	-.22	.01
95%	-1	4.1	17	29	7	18	11	5	-3	4	-.14	-.28	.02

Non-Parents (2009)

	CED	BW	WW	YW	MILK	TM	ME	HPG	CEM	ST	MARB	REA	FAT
Min	-12	-11.1	-11	-14	-2	-2	-16	-1	-11	0	-.30	-.56	-.04
Avg	6	0.3	32	56	17	32	4	9	3	9	.07	.07	.00
Max	22	12.6	68	109	33	62	24	18	16	23	.57	.73	.04
Var	14	4.8	66	182	22	51	13	3	9	8	.01	.03	.00
1%	15	-4.8	51	87	28	49	-4	13	10	15	.32	.46	-.02
2%	14	-4.2	49	84	27	47	-3	13	9	15	.29	.41	-.02
3%	13	-3.8	47	81	26	45	-3	12	9	14	.27	.38	-.01
4%	12	-3.5	46	80	25	44	-2	12	8	14	.26	.36	-.01
5%	12	-3.3	45	78	25	44	-2	12	8	14	.25	.34	-.01
10%	11	-2.5	42	73	23	41	-1	11	7	13	.21	.28	-.01
15%	10	-2.0	40	70	22	39	0	11	6	12	.18	.24	-.01
20%	9	-1.5	39	67	21	38	1	11	5	11	.16	.21	-.01
25%	8	-1.2	37	65	20	37	2	10	5	11	.14	.18	-.01
30%	8	-0.8	36	63	19	36	2	10	5	10	.13	.16	.00
35%	7	-0.5	35	61	19	35	3	10	4	10	.11	.13	.00
40%	7	-0.3	34	59	18	34	3	9	4	10	.10	.11	.00
45%	6	0.0	33	58	18	33	4	9	3	9	.08	.09	.00
50%	6	0.3	32	56	17	32	4	9	3	9	.07	.07	.00
55%	6	0.6	31	54	16	31	4	9	3	9	.06	.05	.00
60%	5	0.9	30	53	16	30	5	9	2	8	.04	.03	.00
65%	5	1.1	29	51	15	29	5	8	2	8	.03	.01	.00
70%	4	1.4	28	49	15	28	6	8	1	8	.01	-.02	.00
75%	4	1.8	27	47	14	27	6	8	1	7	.00	-.04	.01
80%	3	2.1	25	45	13	26	7	7	1	7	-.02	-.07	.01
85%	2	2.6	24	42	12	25	8	7	0	6	-.04	-.10	.01
90%	1	3.1	22	39	11	23	9	7	-1	5	-.07	-.14	.01
95%	0	3.9	19	34	9	20	10	6	-2	4	-.11	-.20	.01

EPD Accuracies and Possible Change

EPDs are predictions, not true values, and we can therefore expect that EPDs will change from sire evaluation, as more information (i.e. progeny data) is included. A possible change value is an estimate of the amount of change (in trait units) that can be expected for a given EPD.

Technically, there is a 68% chance that the real genetic value (an EPD with a accuracy of 1.0) for any trait lies between its EPD plus its possible change value and its EPD minus its possible change value. For example, if a sire has a weaning EPD of +25 lb. and a possible change value of 10 lb., we can expect the true genetic value to be between +15 lb. (25 - 10) and +35 lb. (25 + 10) 68% of the time. We should not be surprised if his EPD in next year's evaluation is as high as +35 or as low as +15. If next year's EPD should happen to be slightly outside of this

range, keep in mind there is nearly a one-in-three chance of that happening; however, significantly larger deviations can occur.

Possible change is simply another way of expressing accuracy of an EPD. High accuracy sires will have small possible changes and vice versa. Many breeders feel that possible change values complement accuracies and help them determine just how thoroughly an animal has been evaluated. The accuracy/possible change chart lists possible changes in EPDs that can be expected with different levels of accuracy for the various traits.

For more information on possible change values, please see the article by Dr. Bob Hough titled "Understanding EPD Accuracies and Possible Change". This article can be downloaded from the Red Angus Association of America website at www.redangus.org.

Accuracy	CED	BW	WW	YW	MILK	ME	HPG	CETM	ST	MARB	REA	FAT
0.0	9	3.0	12	15	9	3	11	9	7	.24	.31	.03
0.1	8	2.7	11	14	8	2	10	8	6	.22	.28	.03
0.2	7	2.4	9	12	7	2	9	7	5	.19	.25	.02
0.3	6	2.1	8	11	6	2	8	6	5	.17	.22	.02
0.4	5	1.8	7	9	5	2	7	5	4	.14	.19	.02
0.5	4	1.5	6	8	4	1	6	4	3	.12	.16	.01
0.6	3	1.2	5	6	4	1	4	4	3	.10	.12	.01
0.7	3	0.9	4	5	3	1	3	3	2	.07	.09	.01
0.8	2	0.6	2	3	2	1	2	2	1	.05	.06	.01
0.9	1	0.3	1	2	1	0	1	1	1	.02	.03	.00
1.0	0	0.0	0	0	0	0	0	0	0	.00	.00	.00

Sire Bloodline Charts

Name Family

- Champ H
- Clifftop B
- Clipper C
- Cobalt C
- Cody C
- Colt C
- Copper B
- Dominor D
- Emcee E
- Emperor E
- Epic E
- Epitomy E
- Exeter E
- Hasten H
- Herald H
- Heritage H
- Hilltop B
- Hustler H
- Javelin L
- Jet J
- Jules J
- Julian J
- Julio J
- Juniper J
- Juno J
- Jupiter J
- Justice J
- Lancer L
- Lamar L
- Lariat L
- Legend L
- Likable L
- Loki L
- Nebula N
- Neptune N
- Neva V
- Nomad V
- Ranger R
- Roman J
- Scamp J
- Varo R
- Vega V
- Vegas V
- Warhawk W
- Warrior W

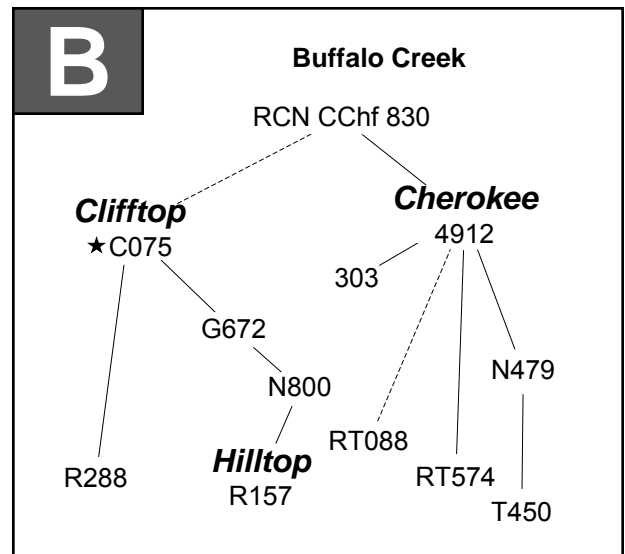
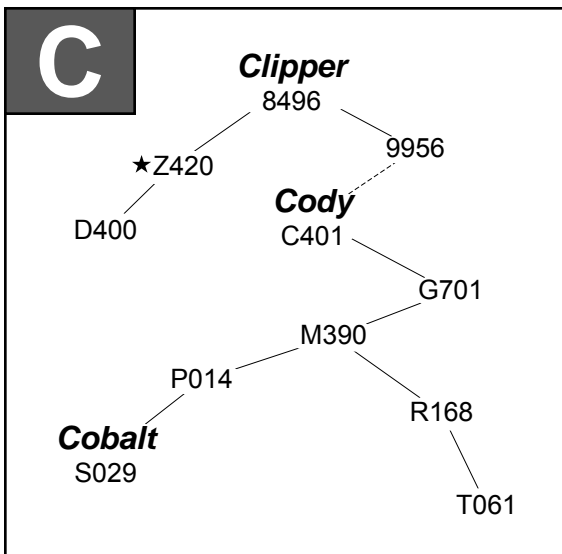
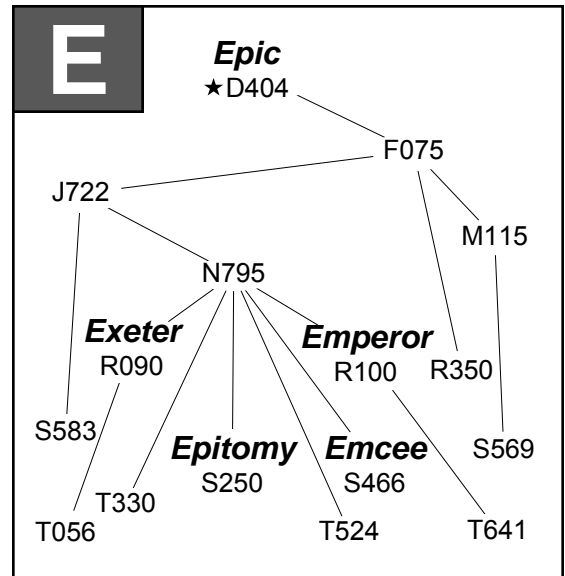
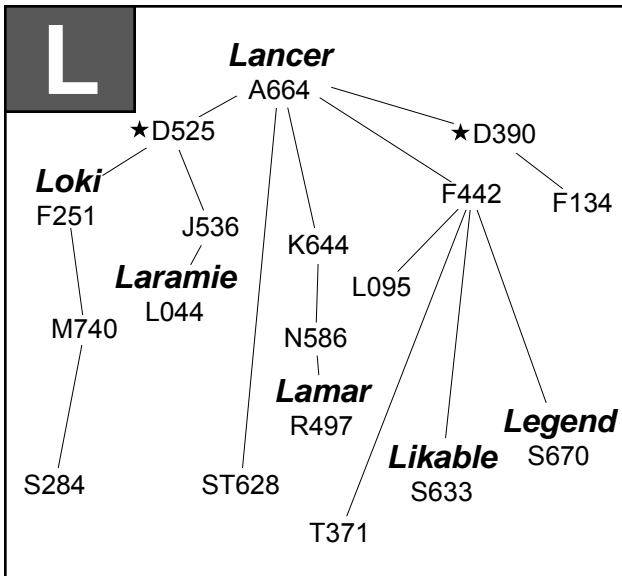
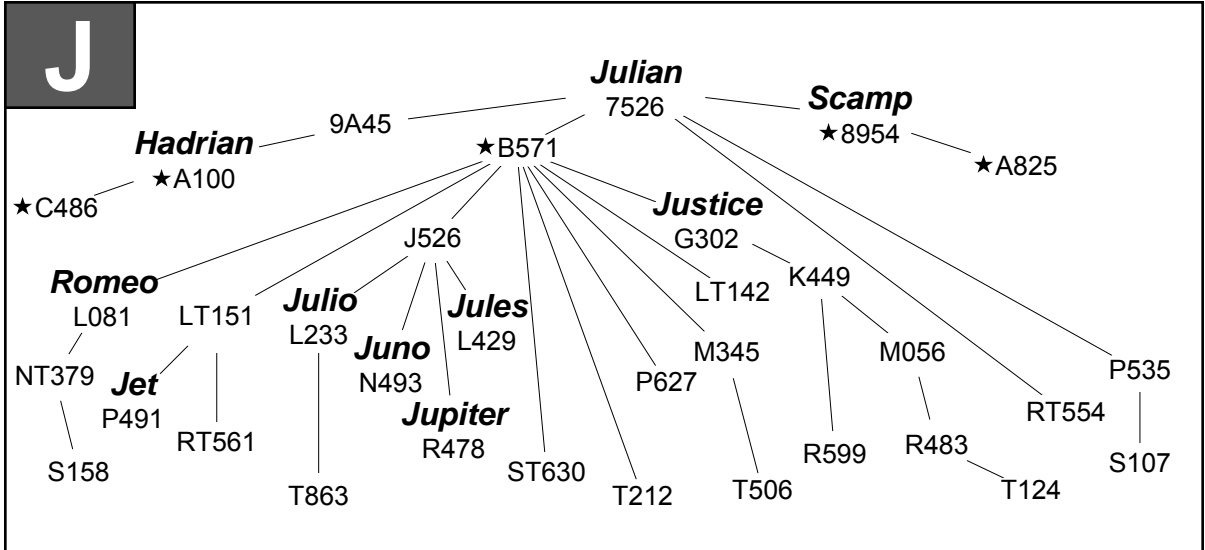

★ Red Angus Trait Leader

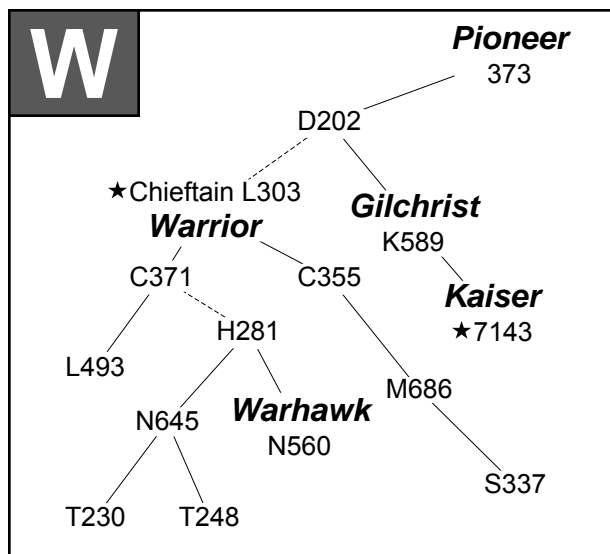
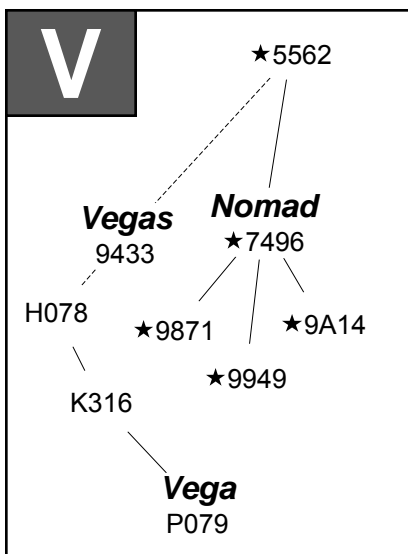
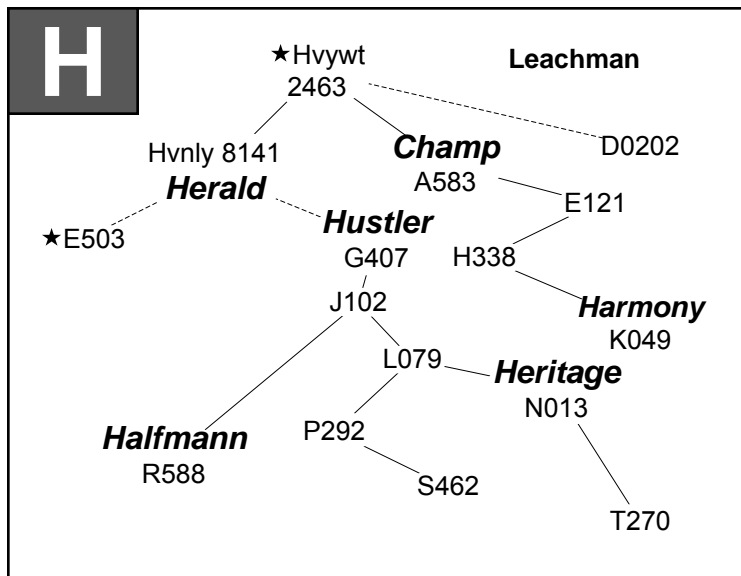
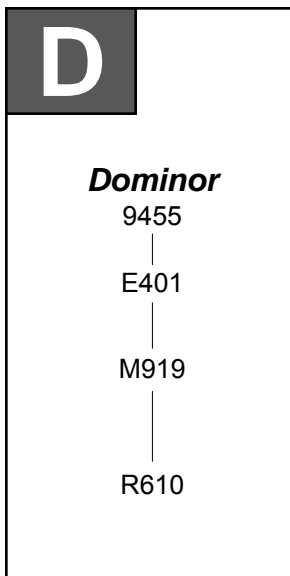
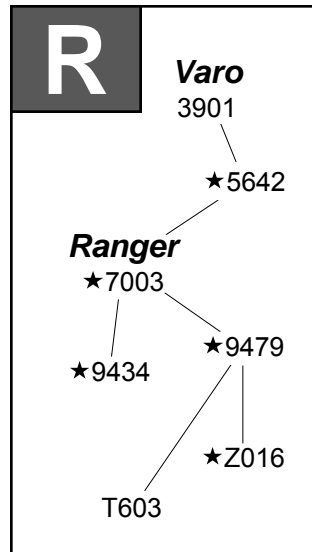
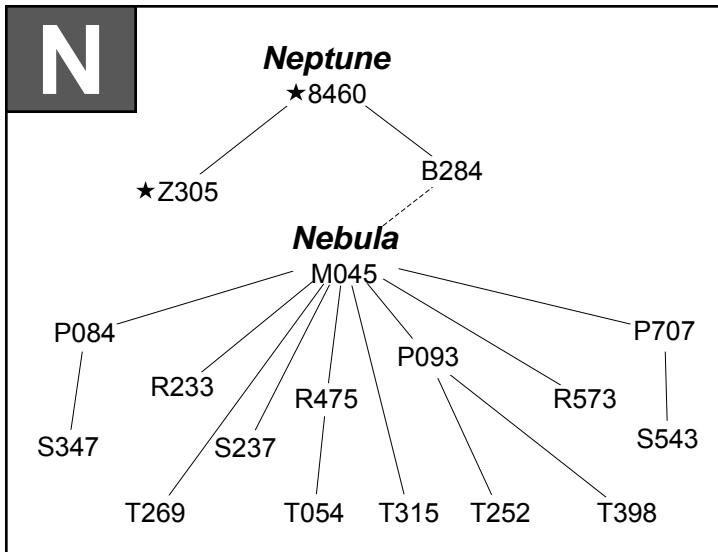

Name	Tag	Family
Julian	7526	J
Lancer	A664	L
Julian	B571	J-1
Epic	D404	E
Epic	F075	E
Lancer	F442	L-1
Julian	J526	J
Epic	J722	E
Hustler	L079	H
Julio	L233	J-2
Julian	LT151	J-11
Nebula	M045	N-1
Justice	M056	J-3
Epic	M115	E-1
Julian	M345	J
Cody	M390	C
Warrior	M686	W
Loki	M740	L
Dominor	M919	D
Heritage	N013	H-1
Cherokee	N479	B-1
Juno	N493	J
Warhawk	N560	W
Lancer	N586	L-2
Warrior	N645	W-1
Epic	N795	E-2
Clifftop	N800	B-2
Romeo	NT379	J
Cody	P014	C-1
Vega	P079	V-1
Nebula	P084	N-2
Nebula	P093	N-3
Hasten	P292	H
Jet	P491	J-4
Julian	P535	J-5
Julian	P608	J-6
Julian	P627	J
Nebula	P707	N-4
Exeter	R090	E
Emperor	R100	E
Hilltop	R157	B
Cody	R168	C-2
Nebula	R233	N
Clifftop	R288	B-3
Epic	R350	E-3
Nebula	R475	N
Jupiter	R478	J
Justice	R483	J-7
Nebula	R573	N-5
Halfmann	R588	H-2
Justice	R599	J
Dominor	R610	D
Julian	RT561	J-13
Cobalt	S029	C-3
Julian	S107	J-8
Roman	S158	J-9
Nebula	S237	N-6
Epitomy	S250	E
Loki	S284	L-3
Warrior	S337	W-2
Nebula	S347	N-7
Hasten	S462	H-3
Emcee	S466	E-4
Nebula	S543	N-8
Epic	S569	E-5
Epic	S583	E
Likable	S633	L-4
Legend	S670	L

Notes

Beckton History



Sal keeping records.



Waldo Forbes - 1st President of the Red Angus Association.



Beckton house/office before being moved in 1905 to its current location. This house was built in the 1880s by George Beck, the original homesteader. The antlers are still on the porch, and it is one of the oldest buildings in Sheridan County.



The Waldo Forbes family in 1959: Ellen, Julia, Sal, Sarah, Cherry,, Spike, and Cam & Elfie in front.



Inspection Committee at Beckton (1954), including George and Vernice Chiga, Sal and Waldo Forbes and Spike.



Beckton Larkabeau O "220" in 1959 - the 1st Red Angus Bull at ABS



Forrest Bassford and Sal Forbes

Lot-Tag Cross Reference

ID	Lot	ID	Lot	ID	Lot	ID	Lot	ID	Lot	ID	Lot	ID	Lot
<i>Reference Sires</i>		<i>Beckton Bulls</i>		U213	.75	U421	.115	U603	.5	U793	.150	<i>Tongue River Bulls</i>	
B571	J-1	T826	.1	U215	.29	U425	.105	U604	.18	U799	.193	UT800	.2
F442	L-1	U001	.151	U220	.223	U426	.169	U605	.144	U802	.139	UT803	.202
L233	J-2	U002	.85	U223	.3	U427	.158	U609	.14	U803	.195	UT804	.199
LT142	J-10	U005	.39	U224	.110	U430	.22	U614	.119	U805	.70	UT805	.203
LT151	J-11	U006	.52	U228	.33	U434	.38	U617	.67	U808	.231	UT806	.90
M045	N-1	U008	.111	U236	.36	U435	.77	U618	.172	U809	.118	UT811	.6
M056	J-3	U014	.83	U238	.153	U437	.93	U620	.147	U811	.164	UT816	.7
M115	E-1	U017	.177	U241	.26	U438	.230	U622	.104	U815	.141	UT818	.88
N013	H-1	U019	.211	U243	.57	U441	.145	U634	.188	U818	.215	UT819	.91
N479	B-1	U020	.17	U245	.98	U442	.233	U644	.94	U822	.148	UT822	.136
N586	L-2	U023	.209	U252	.225	U452	.189	U649	.72	U825	.196	UT824	.20
N645	W-1	U024	.130	U256	.226	U468	.207	U659	.121	U830	.197	UT825	.19
N795	E-2	U032	.214	U260	.50	U469	.205	U661	.68	U831	.99	UT827	.204
N800	B-2	U035	.13	U264	.171	U470	.28	U665	.219	U841	.175	UT828	.137
P014	C-1	U037	.186	U266	.84	U474	.55	U674	.25	U847	.66	UT830	.133
P079	V-1	U049	.62	U269	.24	U476	.210	U677	.198	U852	.168	UT834	.135
P084	N-2	U059	.179	U276	.213	U485	.23	U678	.191	U856	.224	UT837	.134
P093	N-3	U071	.162	U277	.35	U486	.41	U679	.102	U861	.236	UT838	.200
P491	J-4	U077	.160	U280	.10	U493	.159	U681	.120	U865	.127	UT840	.201
P535	J-5	U078	.37	U286	.229	U494	.106	U682	.185	<i>Beckton Heifers</i>		UT841	.89
P608	J-6	U080	.107	U291	.51	U496	.128	U690	.87	U012	.323	UT844	.92
P707	N-4	U082	.161	U292	.42	U497	.149	U694	.59	U070	.328	<i>Tongue River Heifers</i>	
R168	C-2	U086	.155	U299	.40	U502	.132	U696	.131	U135	.308	UT821	.312
R288	B-3	U087	.116	U300	.16	U503	.146	U705	.73	U184	.310	UT829	.314
R350	E-3	U094	.80	U302	.140	U506	.152	U712	.222	U251	.341	UT852	.318
R483	J-7	U098	.47	U305	.78	U507	.183	U714	.234	U267	.305	UT856	.320
R573	N-5	U104	.76	U307	.44	U509	.178	U716	.167	U287	.342	UT858	.315
R588	H-2	U110	.163	U311	.71	U513	.142	U718	.228	U304	.309	UT861	.316
RT088	B-4	U112	.166	U323	.54	U516	.117	U721	.123	U308	.326	UT862	.319
RT554	J-12	U116	.206	U333	.122	U517	.48	U722	.109	U320	.304	UT866	.333
RT561	J-13	U127	.69	U336	.95	U520	.46	U723	.227	U356	.330	UT868	.337
RT574	B-5	U136	.218	U345	.64	U525	.180	U732	.220	U362	.325	UT870	.336
S029	C-3	U139	.126	U348	.208	U536	.194	U734	.74	U479	.329	UT873	.317
S107	J-8	U140	.129	U349	.30	U537	.114	U735	.156	U534	.327	UT874	.311
S158	J-9	U141	.65	U357	.8	U538	.86	U744	.143	U608	.307	UT875	.340
S237	N-6	U144	.125	U363	.53	U541	.101	U745	.187	U611	.324	UT879	.334
S284	L-3	U149	.49	U366	.184	U543	.235	U747	.56	U628	.301	UT880	.332
S337	W-2	U154	.124	U368	.103	U552	.112	U758	.221	U646	.322	UT883	.339
S347	N-7	U161	.81	U390	.182	U553	.154	U759	.192	U740	.343	UT884	.335
S462	H-3	U163	.108	U397	.79	U555	.21	U761	.173	U763	.344	UT890	.331
S466	E-4	U178	.176	U400	.61	U559	.174	U767	.60	U791	.303	UT893	.313
S543	N-8	U180	.63	U402	.113	U565	.32	U768	.11	U798	.321	UT894	.338
S569	E-5	U183	.212	U403	.31	U567	.34	U772	.165	U848	.302		
S633	L-4	U191	.43	U405	.216	U568	.157	U779	.190				
ST628	L-5	U192	.45	U411	.82	U573	.15	U782	.12				
ST630	J-14	U199	.4	U412	.58	U578	.9	U783	.181				
		U200	.96	U419	.217	U580	.138	U784	.232				
		U207	.27	U420	.170	U594	.100	U787	.97				

Special Semen Sires



Beckton HalfmannHustler R588

H-2 BECKTON HALFMANNHUSTLER R588

1-A 100% # 1042326 Tattoo: BKT5 R588

Birth: 4-1-05

Beckton Hustler C G407

BECKTON HUSTLER CN J102

Ref. H

Beckton Belga G355 NP

Beckton Clipper JM A124

BECKTON VERNICE F513 CL

Beckton Vernice A663 PC

LCC Heaven or Bust 1000B

Beckton Rose E032 CL

Beckton Neptune RR B284

Beckton Belga B061 ZN

Beckton Clipper J 9956

Beckton Mona 9766 MJ

Beckton Pacer 8940

Bkt Vernice 8994 NM

DAM		Calv.Ease	BW	WW	YW	Milk	HPG	Stay	Maint.En.
Age	10	-5	+12.0	32	67	11	7	11	+5.0
Wt	1305	(.21)	(.36)	(.28)	(.29)	(.23)	(.16)	(.01)	(.16)
Wean Pct.	48%	Marb -.11 (.30)		REA -.04 (.28)		Bfat -.02 (.22)			
Cow Eff.	100	BWt	WWt	WR	ADG	YWt	YR	Scr.	Fr.
		67	620	103	5	1222	111	36	6.0

Beckton HalfmannHustler R588 is another outstanding sire for phenotype and eye appeal. He spreads calving ease and growth like few sires. And he is a rare sire that is homozygous for tenderness genes, scoring the highest rating of 10 on Igenity's scale, and the maximum Six Star rating by Genestar. Quantity limited, but also available through co-owners Halfmann Red Angus of Miles, Texas.



Beckton Warrior N645 T1

N-3 BECKTON NEBULA L P093

1-A 100% # 978419 Tattoo: WF4 P093

Birth: 2-28-04

Beckton Neptune R2 K065

BECKTON NEBULA M045

Ref. N-2

Beckton Belga K285 JL

Beckton Lancer TA K644

BECKTON MARTA M021 LN

Beckton Marta K254 LN

Beckton Neptune RR B284

Beckton Lana C735 TP

Beckton Julian GG B571

Beckton Belga G493 HR

Beckton Lancer T A664

Beckton Tamara B570 JL

Beckton Lancer T A664

Beckton Marta G512 LN

DAM		Calv.Ease	BW	WW	YW	Milk	HPG	Stay	Maint.En.
Age	2	-3	+14.0	36	71	3	8	15	-3.7
Wt	775	(.40)	(.77)	(.67)	(.62)	(.37)	(.01)	(.01)	(.27)
Wean Pct.	63%	Marb +.13 (.44)		REA +.37 (.40)		Bfat -.01 (.24)			
Cow Eff.	132	BWt	WWt	WR	ADG	YWt	YR	Scr.	Fr.
		69	560	101	4	1067	105	35	5.5

Nebula M045 is being leased to ABS, but we have available semen for sons that we are using. Nebula P093 is his top son for growth. His calves rank well above the average for our herd at both weaning and yearling. P093 was a large rib-eye bull as a yearling, and his calves are being measured with large rib-eyes. P093's carcass Rib-eye EPD is high and climbing. Commercial quantities available.

N-4 BECKTON NEBULA P P707

1-A 100% # 979031 Tattoo: BKT4 P707

Birth: 4-1-04

Beckton Neptune R2 K065

BECKTON NEBULA M045

Ref. N-2

Beckton Belga K285 JL

Beckton Epic K1 K863

BECKTON LANA M809 EP

Beckton Lana K253 DM

Beckton Neptune RR B284

Beckton Lana C735 TP

Beckton Julian GG B571

Beckton Belga G493 HR

Beckton Epic KN H110

Beckton Rose H019 SC

Beckton Dominor ZJ H657

Beckton Lana HA34 DM

DAM		Calv.Ease	BW	WW	YW	Milk	HPG	Stay	Maint.En.
Age	2	-5	+16.0	37	71	15	8	13	-7.8
Wt	890	(.50)	(.68)	(.61)	(.58)	(.49)	(.15)	(.01)	(.37)
Wean Pct.	71%	Marb +.18 (.34)		REA +.13 (.31)		Bfat +.01 (.21)			
Cow Eff.	150	BWt	WWt	WR	ADG	YWt	YR	Scr.	Fr.
		68	728	127	4	1265	122	37	5.0

Nebula P707 amplifies the maternal traits of the Nebula line. He is out of a high milking 2 year old Lana dam, and that maternal line is carrying forward, because his own daughters are milking very well. She was a modest sized dam, and P707's frame is 5.2, so we are seeing a very efficient, low maintenance sire that puts significant growth on his calves.

W-1 BECKTON WARRIOR N645 T1

1-A 100% # 916767 Tattoo: BKT3 N645

Birth: 4-2-03

Beckton Warrior TC E801

BECKTON WARRIOR T1 H281

Ref. W

Beckton Minerva B609 RN

Beckton Epic K F075

BECKTON ROSE H074 EP

Beckton Rose F791 EM

Beckton Warrior T C371

Beckton Minola C251 NM

Beckton Ranger H Z095

Beckton Minerva Z936 RN

Beckton Epic D404

Beckton Belga D483 KR

Beckton Emperor C369

Beckton Rose C794 KR

DAM		Calv.Ease	BW	WW	YW	Milk	HPG	Stay	Maint.En.
Age	5	0	+5.0	40	78	8	9	10	-1.0
Wt	1020	(.31)	(.66)	(.54)	(.45)	(.27)	(.15)	(.01)	(.16)
Wean Pct.	67%	Marb -.01 (.36)		REA +.01 (.34)		Bfat +.01 (.23)			
Cow Eff.	140	BWt	WWt	WR	ADG	YWt	YR	Scr.	Fr.
		85	679	117	3	1204	115	37	6.5

Beckton Warrior N645 T1 was the most outstanding bull for performance and phenotype in our 2003 calf crop. His calves stand near the top of the herd for growth and appeal, yet Warrior also ranks in the very top of the breed for lowest Maintenance Energy EPD. Quantity limited.

Beckton Stock Farm

Cam, Spike, and Sal Forbes

37 Beckton Drive

Sheridan, WY 82801

Tel.: 307.674.6095, 674.8162 (evening)

Fax: 307.672.7281

Email: beckton@wavecom.net



FIRST CLASS



LOW MAINTENANCE

Beckton's herd has the lowest Maintenance Energy requirements EPD of any major Red Angus herd. The average Maintenance Energy EPD of our sale bulls is -2, so that as a group these Beckton sale bulls will be at the top 5% of the breed for reducing cowherd feed needs. Many are in the top 1-2%. Almost all will be better than breed average. These bulls bring you the genetics to reduce long-term operating costs.



EARLY GROWTH

The average Beckton bull in this sale is also +58 for yearling weight EPD, higher than breed average, so you get genetics for early growth to market weight without the large mature size.



CARCASS QUALITY

The average Beckton bull listed is also well into the upper half of the breed for both Marbling EPD and Ribeye EPD (actually near the top third), so you get genetics that will position your cattle well in the end-product market.



CALVING EASE

The Calving Ease EPD for the average Beckton bull in this sale is +12, in the top 5% of the breed as well. With Beckton bulls you get the maximum in calving ease and calf survival.

Free Delivery
anywhere in the Continental US